

BRIDGEMAN'S  
CALIFORNIA SERIES

California  
Regional  
Library

*Presented in honor of*

Alfons I. Wray, D.O., F.O.C.O.



COLLEGE OF OSTEOPATHIC PHYSICIANS  
AND SURGEONS • LOS ANGELES, CALIFORNIA



AUG 27 1907

352

DR. L. A. PERCE  
LONG BEACH, CAL.



Digitized by the Internet Archive  
in 2007 with funding from  
Microsoft Corporation





Professor Wilhelm Conrad Röntgen.



Statue of Professor Röntgen on the Potsdam Bridge, Berlin.

LIPPINCOTT'S NEW MEDICAL SERIES

Edited by FRANCIS R. PACKARD, M.D.

---

RÖNTGEN RAYS  
AND  
ELECTRO-THERAPEUTICS

WITH CHAPTERS ON RADIUM  
AND PHOTOTHERAPY

BY

MIHRAN KRIKOR KASSABIAN, M.D.

Director of the Röntgen Ray Laboratory of Philadelphia Hospital; Formerly in charge of the Röntgen Ray Laboratory and Instructor in Electro-Therapeutics in Medico-Chirurgical Hospital and College; Member of the Philadelphia County Medical Society; Pennsylvania State Medical Society; American Medical Association; American Röntgen Ray Society; Vice-President of the American Physico-Electro-Therapeutic Association; New York Medico-Legal Society; etc., etc.



PHILADELPHIA & LONDON  
J. B. LIPPINCOTT COMPANY

WN100  
K 19r  
1907

Copyright, 1907, by J. B. Lippincott Company

TO  
MY MOTHER AND MY BROTHERS  
I DEDICATE THIS VOLUME  
AS A TOKEN OF RESPECT AND AFFECTION.

THE AUTHOR.

“You go not till I set you up a glass,  
Where you may see the inmost parts of you.”

HAMLET, *Act III. Scene IV.*

“In wonder all philosophy began, in wonder  
it ends, and admiration fills up the interspace ; but  
the first wonder is the offspring of ignorance, the  
last is the parent of adoration.”

COLERIDGE.



22  
W  
1907

## PREFACE

---

THE object of this book, as indicated by its title, is to present, clearly and concisely, the more important facts pertaining to electro-therapeutics and the Röntgen rays. Notwithstanding the many valuable and important treatises extant on both these subjects, the author has keenly felt the need of something more, and he has endeavored to offer, in a condensed but comprehensive manner, the theories and applications of electrical energy, in its various forms, to the domain of medicine.

The initial portion of the work is devoted to the subject of electro-therapeutics, whose compendious character, it is believed, will appeal to the practical physician. Beginning with the definition of electrical terms, this division of the work gradually leads the reader to an elaborate description of high-frequency currents, which have recently opened up so fertile and promising a field. As in other portions of the volume, the introduction of debatable questions and mathematical formulas has been studiously avoided, and no space has been encumbered with the recital of fanciful theories or those of a controversial nature.

An exhaustive study of the Röntgen rays follows. The author has bestowed much care to a description of the apparatus employed, believing that its thorough mastery is essential to a complete understanding of the subject. The technic of radio-photography is treated of at length, because an intimate knowledge of this department is indispensable for the production of successful skiagraphs, and if the chapter on stereo-skiagraphy seems extensive, it is due to the fact that the author regards the subject as one of constantly growing importance. A word regarding X-ray dosage. Lack of a standard unit of measurement in X-ray therapy has compelled the lengthy discussion of the various methods in vogue. It is believed, however, that this is a valuable addition to the work, and may perhaps prove a convenience to many, who find the literature on this subject to be widely scattered. Much thought has been bestowed on the technic of dental skiagraphy, and the same may be said of the chapter on the localization of foreign bodies. With an experience of more than eight thousand cases under his immediate study and care, the author has preferred, wherever possible, to introduce and quote the views of his confrères, rather than to obtrude his own opinions as the only ones acceptable. Because of the importance of the subject, much space has been assigned to a study of the cathode rays, and to the terse and elegant description of the Röntgen rays, so simply told by Röntgen and so faithfully translated by Professor Barker for Harper and Brothers.

The therapeutic value and the limitations of radium are being thoroughly investigated, and it is still too early to assign any definite place to this remarkable agent in the practice of medicine. A space, all too brief, is allotted to the study of phototherapy, and to the memorable discoveries which the genius of Finsen bequeathed to science.

A striking feature, which will materially add to whatever merit the work may possess, is the introduction, in its final pages, of a study of the technic employed and the remarks made by many of the leading exponents of Röntgen therapy both in this country and in Europe.

In the department of electro-therapeutics the author has freely consulted the works of Rockwell, H. Lewis Jones, Erb, Hedley, and Snow.

In the portion devoted to the Röntgen rays he has referred to the treatises of Caldwell and Pusey, F. Williams, Freund, Bouchard, Isenthal and Ward, and Hyndman.

I wish gratefully to acknowledge my indebtedness to Dr. Samuel Lewald, of this city, who, by his literary skill and unceasing interest in the preparation of the present volume, has greatly lightened the labor of it. A word of thanks is due my colleagues Drs. Charles L. Leonard and William M. Sweet; the former for many suggestions, the latter for valuable advice in regard to the chapter on localization. Mr. H. C. Snook very kindly offered several practical hints on the X-ray apparatus. I am only too conscious of the courtesies shown me by Dr. Francis R. Packard, the editor of Lippincott's New Medical Series.

In conclusion, it seems fitting to remark that to his friends and to the many friends of science, who have urged him on, and encouraged him to the consummation of the present volume, the author feels profoundly grateful.

MIHRAN K. KASSABIAN.

PROFESSIONAL BUILDING,  
Philadelphia, Pa., June, 1907.

# CONTENTS

## PART I. ELECTRO-THERAPEUTICS.

### INTRODUCTION.

	PAGE
HISTORICAL SKETCH OF THE RISE OF ELECTRICITY.....	xxix-xxxi
ELECTRICITY AS A PART OF THE MEDICAL CURRICULUM.....	xxxi, xxxii

### CHAPTER I.

#### ELEMENTARY PRINCIPLES OF ELECTRICITY AND MAGNETISM.

I. Nature and Properties of Magnetism.....	33
A. NATURAL.....	33
B. ELECTRO-MAGNETS.....	33
II. Nature and Properties of Electricity.....	34
A. THEORY OF POTENTIAL.....	34
(a) Hydraulic Analogy.....	34
B. UNITS OF ELECTRICAL MEASUREMENT, C. G. S. SYSTEM.....	36
(a) Electro-static Units.....	36
(b) Magnetic Units.....	36
(c) Electro-magnetic or "Absolute" C. G. S. Units.....	37
(d) Practical Units and Standards.....	37
C. DEFINITIONS AND EQUATIONS.....	38
Conductivity.....	38
Resistance: Ohm's Law.....	39
Ampere; Farad; Watt; Equations.....	39
III. Sources of Electrical Energy.....	39
A. STATIC.....	39
B. GALVANIC.....	39, 40
(a) Primary Batteries: Construction and Connection.....	40
1. Series.....	40
2. Parallel.....	40
3. Group.....	41
(b) Accumulators, Storage or Secondary Batteries.....	41
Principles; Varieties.....	41, 42
Capacity.....	42
Charging from	
1. Primary Cells.....	43
2. 110-Volt.....	44
3. Alternating Current.....	44
4. Bicycle.....	45
5. Thermopiles.....	45

	PAGE
C. DYNAMIC OR ELECTRIC MAINS.....	45
(a) Direct.....	45
(b) Alternating ....	45
D. THERMOPILES .....	45

## CHAPTER II.

## THE STATIC, FRANKLINIC, OR FRICTIONAL CURRENT.

I. The Static or Influence Machines .....	46
Principles of Construction .....	46
A. TYPES OF INFLUENCE MACHINES.....	47
Theory of Action (Wimshurst).....	47
Theory of Action (Holtz).....	49
Theory of Action (Voss or Toepler).....	50
B. CARE AND MANIPULATION OF STATIC MACHINES .....	51
C. ACCESSORIES.....	52
The Leyden Jar.....	52
Electrodes .....	52
Chain-Holder .....	53
Muffler.....	54
Preparation of the Patient.....	54
Polarity .....	54
Idiosyncrasy.....	55
Dosage .....	56
II. The Modes of Application.....	57
A. CONVECTIVE CURRENTS.....	57
Brush Discharge ; Breeze and Spray.....	57
Static Bath ; Interrupted Insulation.....	57
B. DISRUPTIVE CURRENTS .....	58
Direct ; Indirect ; Frictional.....	58
C. CONDUCTIVE CURRENTS.....	58
Static Induced Current .....	58
Wave Current (Morton) .....	58, 59
STATIC MODALITIES (CHART).....	60, 61

## CHAPTER III.

## GALVANIC, CONTINUOUS, OR DIRECT CURRENT.

Galvanic Battery ; Connections.....	62
Types of Cells.....	63
Care of Battery ; Charging the Cells ; Polarity .....	64
Wall Cabinet .....	64
Rheostat ; Electrodes ; Galvanometer ; Milliamperemeter .....	66
Galvano-Faradic Box .....	67
Definition of Terms.....	67
Methods of Application.....	68
Central Galvanization ; Galvano-Faradization.....	69
Cautery Batteries.....	69, 70
Sinusoidal Current.....	70



## CHAPTER IV.

## FARADIC, INTERRUPTED, OR INDUCED CURRENTS.

	PAGE
Principles of Induction.....	71
Faradic Battery.....	71
Medical Induction Coil.....	71, 72
Interrupter or Rheotome.....	73
Method of Application.....	73
Localized Faradization.....	74
As a Diagnostic Agent.....	74
As a Therapeutic Agent.....	74

## CHAPTER V.

I. Cataphoric Method.....	75
II. Hydro-Electric Baths.....	77

## CHAPTER VI.

## ELECTRO-DIAGNOSIS.

The Motor Points.....	81
Upper Limb.....	82
Lower Limb.....	85
Face; Neck.....	85
Segments.....	88
Usual Nerve Supply.....	88
Hints for Practical Testing.....	89
Reaction of Degeneration.....	90
Degeneration of Muscles.....	90
Partial Reaction of Degeneration.....	91
Sensory System; Nerves of Special Sense.....	91

## CHAPTER VII.

## ELECTRO-PHYSIOLOGY.

Influence of Electricity upon Motor Nerves and Muscles.....	92
Pflüger's Laws of Contraction.....	92
Upon Voluntary Muscles.....	94
Electrotonus.....	94
Sensory Cutaneous Nerves.....	95
Sensory Nerves of Muscles.....	95
Upon the Special Senses.....	95, 96
Upon the Sympathetic System.....	96
Upon the Skin.....	97
Upon the Head.....	97
Upon the Spinal Cord.....	97
Upon the Abdominal Organs.....	97, 98
Electrical Currents in Disease.....	98

## CHAPTER VIII.

## PRACTICAL APPLICATIONS IN DISEASED CONDITIONS.

	PAGE
<b>I. Cutaneous System</b> .....	99
Acne; Eczema; Pruritus; Alopecia; Sycosis .....	99
Hypertrichosis.....	100
Psoriasis and Pityriasis; Ringworm and Scleroderma; Prurigo .....	101
Cutaneous Anæsthesia, Herpes Zoster .....	101
Nævus; Port-wine Mark; Moles and Warts; Furuncles and Carbuncles, 102	102
<b>II. Muscular System</b> .....	103
Myalgia; Writer's Cramp.....	103
Torticollis; Muscular Contractions.....	104
Myasthenia Gravis.....	105
<b>III. Articular System</b> .....	105
Synovitis; Hydro-arthritis; Rheumatoid Arthritis .....	105
Chronic Articular Rheumatism; Gout; Tuberculous Arthritis.....	106
Fibrous Ankylosis .....	106
<b>IV. Digestive System</b> .....	107
Vomiting; Dilatation of Stomach.....	107
Nervous Dyspepsia.....	108
Constipation—Method of Application .....	108
Enteritis .....	109
Fissure of the Anus.....	110
Prolapse of the Rectum.....	110
Hemorrhoids .....	111
Stricture of the Rectum.....	111
<b>V. Genito-Urinary System</b> .....	111
Stricture of the Male Urethra.....	111-113
Prostatitis .....	113, 114
Paralysis of the Urinary Bladder.....	114, 115
Incontinence of Urine; Nocturnal Incontinence.....	115
Spermatorrhœa and Seminal Emission .....	115
Impotence.....	116
Orchitis .....	116
Nephritis.....	116
<b>VI. Nervous System</b> .....	116
Neuralgias: Cephalalgia, Tic Douloureux, Peripheral Neuralgia, Sci- atica.....	117, 118
Paralyses: Rheumatic Paralysis, Syphilitic Paralysis, Lead, Arsenic, Opium, etc. ....	118
Hemiplegia; Paraplegia.....	118
Facial Paralysis; Poliomyelitis; Locomotor Ataxia .....	119
Chronic Spinal Muscular Atrophy.....	119
Epilepsy .....	119
Insomnia; Hysteria; Hypochondriasis and Melancholia.....	120
Insanity; Neurasthenia.....	120
Exophthalmic Goitre .....	121

	PAGE
VII. Gynæcology .....	122
<i>Limitations and Possibilities in the Treatment of Diseases of Women</i> ....	122, 123
Amenorrhœa .....	124
Dysmenorrhœa .....	124
Fibroid Tumors.....	124
Ovarian Tumors . . . . .	125
Chronic Metritis .....	125
Periuterine Hæmatocele .....	125
Stenosis of the Cervical Canal.....	125
Subinvolution and Atrophy.....	125
Urethral Caruncle.....	125
Post-partum Hemorrhage.....	125
Vomiting of Pregnancy.....	126
Slow Labor.....	126
VIII. Aneurism .....	127-129

## CHAPTER IX.

## APPLICATIONS IN THE SPECIALTIES.

I. Rhinology and Laryngology.....	129
Atrophic Rhinitis; Pharyngitis; Ozaena .....	129
Anæsthesia of the Pharynx; Laryngeal Fatigue .....	130
Atrophic Pharyngitis; Anosmia .....	130
Asthma .....	131
II. Otology .....	131
Auditory-Nerve Deafness.....	131
Chronic Suppuration of the Middle Ear .....	131
Tinnitus Aurium.....	132
Electricity in Otology (Richardson).....	132-134
III. Ophthalmology.....	134
Paralysis of the Muscles of the Eye.....	134
Blepharospasm .....	134
Cataract .....	135
Electrolysis in Diseases of the Lacrymal Canal .....	135
Retinal Anæsthesia and its Treatment by Voltaic Alternatives.....	135
Miscellaneous Ophthalmic Affections.....	136

## CHAPTER X.

## HIGH-FREQUENCY CURRENTS.

I. Historical Introduction .....	138
II. Principles and Apparatus .....	139
Morton's "Static Induced Current" High-Frequency Apparatus.....	140
D'Arsonval High-Frequency Apparatus.....	141
Tesla's High-Frequency Apparatus .....	142
The Oudin Resonator.....	143
Glass Vacuum Electrodes.....	143
Cataphoresis Electrodes.....	144, 145

	PAGE
III. Physical Properties .....	145
A. INDUCTION EFFECTS .....	145
B. ELECTRO-STATIC EFFECTS .....	145
C. DYNAMIC PROPERTIES .....	145
D. RESONANCE .....	146
IV. Methods of Application .....	146
1. Direct Application .....	146
2. Indirect Application or Auto-conduction by the Solenoid .....	147
3. Auto-condensation .....	148
4. By Local Application .....	148
V. Physiological Properties .....	148
VI. Applications in Various Diseases .....	149-155
Tuberculosis .....	149
Gout ; Rheumatism ; Obesity .....	150
Hysteria .....	151
Lupus Vulgaris .....	151
Rodent Ulcer and Malignant Diseases .....	151
Piles, Rectal Fissures, and Pruritus Ani .....	151
Colitis .....	152
Ozaena .....	152
Epilepsy .....	153
Skin Diseases .....	153
Trachoma .....	154
Dulness of Hearing and Subjective Noises .....	154
Gonorrhœa .....	155

---

## PART II.

### THE RÖNTGEN RAYS IN DIAGNOSIS.

---

Historical Introduction .....	156
1650, Otto von Guericke .....	156
1740, Abbé Nollet .....	156
1834, Sir W. Snow Harris .....	156
1838, Michael Faraday .....	156
1838, Heinrich Geissler .....	156
1840, Clerk Maxwell .....	156
1860, Sir Win. Thomson (now Lord Kelvin) .....	156
1865, Gassiot and Sprengel .....	156, 157
1869, Hittorf .....	157
1876, Goldstein .....	157
1877, Warren de la Rue, Hugo Müller, and W. Spottiswoode .....	157
1879, Sir Win. Crookes .....	157
1883, Wiedemann and J. J. Thomson .....	157
1883-1894, Hertz .....	157
1895, Lenard, Perrin, Elster and Geitel, Röntgen .....	157



	PAGE
Comparative Study of the Properties of the Cathode and the Röntgen Rays . . . . .	158
CATHODE RAYS . . . . .	158
Production ; Radiability . . . . .	158
Fluorescence and Phosphorescence . . . . .	159
Reflection, Refraction, and Polarization . . . . .	159
Chemical Effects ; Physiological Effects . . . . .	159
Various Theories . . . . .	159
RÖNTGEN RAYS . . . . .	160
Production . . . . .	160
Radiability and Penetrative Power . . . . .	160
Fluorescence and Phosphorescence . . . . .	161
Reflection, Refraction, Polarization, and Interference . . . . .	162-166
Chemical Effects . . . . .	166
Physiological Effects ; Various Theories . . . . .	167
Visibility of the Röntgen Rays . . . . .	167
Velocity of Propagation of the X-Rays . . . . .	167
Velocity of the Röntgen Rays . . . . .	168
Charging Action of the Röntgen Rays . . . . .	168

## CHAPTER I.

## THE RÖNTGEN-RAY APPARATUS AND ITS MANIPULATION.

I. The Induction Coil . . . . .	169
A. FARADAY ON THE ELEMENTARY LAWS OF INDUCTION . . . . .	169
B. THE CONSTRUCTION OF THE INDUCTION COIL . . . . .	171
Primary and Secondary Coil . . . . .	171
Condenser and Commutator . . . . .	171, 172
C. INTERRUPTERS . . . . .	172
(a) Mechanical . . . . .	172
Platinum . . . . .	172
Vibrating Hammer . . . . .	172
Independent . . . . .	172
Self-Starting . . . . .	173
Vril . . . . .	173
Mercury . . . . .	173
Dipper . . . . .	173
Rotary . . . . .	173
Disk . . . . .	174
Johnston . . . . .	174
Jet . . . . .	175
(b) Electrolytic . . . . .	175
Wehnelt . . . . .	175
Caldwell and Simon . . . . .	178
D. VARIETIES OF INDUCTION COILS . . . . .	178
(a) Variable Primary Induction Coil ("Jumbo") . . . . .	178, 179
(b) Tesla Coil . . . . .	180
(c) Kinraide . . . . .	181-183
(d) Gaiffe . . . . .	184
(e) Coil without Interrupter ; Max Levy ; Grisson . . . . .	184

	PAGE
II. Discharges in Partial Vacua and the Crookes Vacuum Tube.....	185
A. VARIETIES, TYPES, CONSTRUCTION, AND PRINCIPLES .....	189
(a) Stationary Vacuum .....	189
(b) Self-Regulating and Regenerative .....	189
Heat .....	190
Method by Osmosis.....	194
Mechanical Regeneration.....	194
Electro-static Regeneration.....	195
Water-cooling .....	195
B. THE QUALITY OF THE X-RAYS .....	195
Kind of Electrical Energy Employed.....	195
Condition of the Tubes.....	195
Soft, Medium, and Hard Tubes.....	195
X <sub>1</sub> -rays, X <sub>2</sub> -rays, X <sub>3</sub> -rays, Porter .....	195
Hard, Medium, Soft, Very Soft, Albers-Schönberg.....	195
Fifth Grade, Kienböck .....	196
Osteoscope of Carl Beck ; Spintermeter.....	196
C. CARE OF THE TUBE .....	196
Connecting Leading Wires .....	197
Blackening of the Tube.....	197
Puncture and Explosion of Tube.....	198
III. Fluoroscope and Accessories .....	199
A. CONSTRUCTION OF THE FLUOROSCOPE.....	199
B. SKIAGRAPHIC TABLE .....	200
C. HOFFMAN'S MEASURING STAND AND FRAME .....	200
D. TUBE-HOLDERS .....	201
E. BOX-COVER FOR TUBE .....	202
F. DIAPHRAGM AND COMPRESSION DIAPHRAGM.....	202
IV. Selection and Installation of the X-Ray Apparatus.....	203
A. SELECTION. Hospital, City, Country, Portable Outfits.....	203, 204
B. INSTALLATION. Connections (Diagrams) .....	204-207
C. POLARITY AND CONNECTION OF TUBE.....	207
Advantages of Static Machine.....	208
Disadvantages of Static Machine .....	208, 209

## CHAPTER II.

## THE PRINCIPLES OF TECHNIC.

I. Fluoroscopy.....	210
A. METHODS OF EXAMINATION.....	210
(a) Screen and Fluoroscopic Examinations.....	210
(b) Preparation of the Patient .....	211
(c) Position of Tube .....	212
(d) Position of the Patient .....	213
(e). Size, Shape, and Intensity of Image on the Screen.....	213
B. ADVANTAGES OF FLUOROSCOPY .....	213
C. DISADVANTAGES OF FLUOROSCOPY .....	214

	PAGE
II. Skiagraphy.....	214
A. SYNONYMS, DEFINITION, AND NOMENCLATURE.....	214
B. THE PATIENT .....	216
History Taking.....	216
Preparation of the Patient.....	216
Position of Patient .....	216
Immobilization of Part .....	217
C. PLATES, THEIR PREPARATION, SIZE, AND PROTECTION .....	217
Data on the Negative .....	218
D. SELECTION AND USE OF THE CROOKES TUBE.....	218
Position of the Tube.....	218
Form of the Ray-emitting Area of the Anti-cathode.....	219
Direction of the Rays.....	219
Anodal Distance of the Tube from the Plate .....	219
E. FACTORS VARYING THE TIME OF EXPOSURE.....	220
The Capacity of the Apparatus .....	220
The Peculiarity of the Part to be Examined .....	220
Quality of the Rays.....	220
Intensifying Screens .....	220
F. PREVENTION OF SECONDARY OR SAGNAC RAYS.....	220
Lead Iris Diaphragm .....	221
III. Photography .....	221
Dark Room ; Light.....	221
Sensitive Plates and Films .....	222
Care of the Plates.....	222
A. DEVELOPERS ; FORMULAS ; VARIETY .....	222
(a) Reducing.....	222
(b) Preservative .....	223
(c) Accelerating .....	223
(d) Restraining.....	224
Tropical Developer.....	224
B. MODUS OPERANDI OF DEVELOPMENT.....	224
Developing : Rapid ; Slow Process (Tank).....	226
Fixing, Washing, Drying, and Hardening .....	227-229
C. IMPROVEMENT OF THE NEGATIVE .....	229
Intensification .....	229
General and Local Reduction .....	230
Causes and Prevention of Faulty Negatives : Fogging, Stains, Spots.....	231
D. PRINTING (POSITIVE); TONING AND MOUNTING.....	231
Dodging.....	232
Ground-Glass Substitute .....	232
Developing Papers .....	232
Toning Process and Formula.....	233
Printing and Mounting ; Positives.....	233
Transparencies and Lantern Slides.....	234

	PAGE
<b>IV. The Interpretation of X-Ray Negatives</b> .....	234
What Constitute Satisfactory Negatives.....	234
How to View the Negative.....	234, 235
The Proper Light; Author's Examining Box .....	235, 236
A. FOREIGN BODIES .....	236
B. FRACTURES AND DISLOCATIONS .....	237
C. DISEASES AND TUMORS OF THE BONES .....	238
D. DISEASES OF THE SOFT STRUCTURES .....	238
E. DISEASES OF THE THORACIC ORGANS.....	238-240
F. ALIMENTARY SYSTEM .....	240
G. GENITO-URINARY SYSTEM .....	240-242
<b>V. Stereo-Fluoroscopy and Skiagraphy</b> .....	242
A. HISTORY AND PRINCIPLES.....	242, 243
B. STEREO-FLUOROSCOPY .....	243
C. TECHNIC OF STEREO-SKIAGRAPHY .....	244-249
D. METHODS OF VIEWING STEREO-SKIAGRAMS.....	249
Wheatstone .....	249
Brewster.....	249
Plastography .....	250
E. ADVANTAGES OF STEREO-SKIAGRAPHY.....	250
Anatomy; Surgery.....	251

### CHAPTER III.

#### THE CLINICAL APPLICATIONS OF THE RÖNTGEN RAYS.

<b>I. The Uses of X-Rays in Anatomy and Physiology</b> .....	252
A. BLOOD-VESSELS AND RESPIRATORY TRACT .....	252
B. BONES AND JOINTS .....	253, 254
C. PHYSIOLOGY OF PHONATION .....	255, 256
<b>II. Diagnostic Value in Fractures and Dislocations and Callus Formation</b> ....	256
A. THE ADVANTAGES OF THE RÖNTGEN RAY METHOD IN THE DIFFERENTIATION OF COMPLICATED FRACTURES .....	257
B. DISEASES AND TUMORS OF THE BONES AND JOINTS .....	258
C. VALUE IN THE TREATMENT OF FRACTURES .....	259
D. STUDY OF CALLUS FORMATION.....	259
Duration and Varieties.....	259
Perfect Apposition of Fragments.....	260
Slight Overlapping .....	260
False Joint.....	260
Fractures with Extensive Displacements .....	260
Structure of the Callus .....	260
<b>III. Fractures and Dislocations of the Upper Extremity</b> .....	260
HAND. Fluoroscopic Examination.....	260
Skiagraphic Examination.....	261
WRIST-JOINT. Fluoroscopic and Skiagraphic Examinations.....	261
LOWER END OF RADIUS AND ULNA .....	261
FOREARM .....	262
ELBOW-JOINT. Fluoroscopic and Skiagraphic Examinations .....	263



	PAGE
MIDDLE THIRD OF THE HUMERUS .....	264
SHOULDER-JOINT. Fluoroscopic and Skiagraphic Examinations.....	264
Dislocations .....	264, 265
CLAVICLE. Skiagraphic Examination.....	265
SCAPULA. Skiagraphic Examination .....	265
FRACTURES OF THE SKULL. Skiagraphic Examination.....	265
<b>IV. Fractures and Dislocations of the Lower Extremity.....</b>	<b>266</b>
FOOT .....	266
ANKLE .....	267
LEG (MIDDLE THIRD).....	268
KNEE-JOINT; PATELLA .....	268
FEMUR (MIDDLE AND LOWER THIRDS).....	269
HIP-JOINT.....	269
THE OS INNOMINATA, SACRUM, AND COCCYX.....	270, 271
THE SPINAL COLUMN.....	271
RIBS AND STERNUM .....	272
<b>V. Diseases of the Osseous System .....</b>	<b>272</b>
A. PATHOLOGICAL CONDITIONS .....	273
Acute and Chronic Periostitis and Osteomyelitis.....	273
Tuberculosis of Bone.....	273
Syphilis of Bone .....	273
Hypertrophic Deforming Osteitis (Paget's Disease) .....	273
Leprosy .....	273
Acromegaly .....	274
Rickets.....	274
Cretinism.....	274
Osteomalacia .....	274
Necrosis and Caries.....	274
B. TUMORS OF THE BONES.....	274
Sarcoma, Carcinoma, and Cysts.....	275
C. DEFORMITIES OF BONES .....	275
Congenital .....	275
Exostoses.....	275
Deformities of Intra-uterine Origin.....	275, 276
Diseases and Deformities of the Spinal Column.....	276
Torticollis .....	276
Pott's Disease.....	276
Amputation Stumps .....	276
Resection of Joints.....	277
Regeneration of Bone.....	277
<b>VI. Diseases and Tumors of the Soft Tissues.....</b>	<b>277</b>
Hæmatomata .....	277
Abscesses .....	277
Myomata and Fibromata .....	278
Enchondromata; Lipomata; Sarcomata; Carcinomata .....	278
Tumors of the Brain.....	278
Reports of Cases .....	279-282
Calcareous Deposits in Glands .....	282

	PAGE
<b>VII. The Articular System</b> .....	282
<b>A. DISEASES OF THE JOINTS</b> .....	282
Acute Arthritis .....	282
Acute and Chronic Articular Rheumatism .....	282
Gout .....	282
Tuberculous Arthritis .....	283
Coxalgia .....	283
Coxa Vara .....	283
Genu Valgum .....	284
Genu Varum .....	284
<b>B. ARTHROPATHIES</b> .....	284
Tabes; Syringomyelia .....	284
<b>VIII. Foreign Bodies and their Localization</b> .....	285
<b>A. MILITARY SURGERY</b> .....	285
Græco-Turkish War .....	285
Chitral Campaign .....	285
Soudan .....	285
Spanish-American War .....	285
South Africa .....	286
Russo-Japanese War .....	286
<b>B. VARIETIES OF FOREIGN BODIES</b> .....	286
Transparent; Translucent; Opaque .....	286
Table of Permeability of Röntgen Rays .....	287
<b>C. FOREIGN BODIES IN THE DIGESTIVE, RESPIRATORY, AND GENITO-URINARY TRACTS</b> .....	287
Esophagus .....	287
Stomach .....	288
Intestines .....	288
Larynx, Trachea, and Bronchi .....	288
Genito-Urinary Tract .....	288
Foreign Bodies entering from Without .....	289
<b>D. THE X-RAYS IN OPHTHALMOLOGICAL SURGERY</b> .....	289
Foreign Bodies in the Eye .....	289
Sweet's Method of Localization .....	290-295
Davidson's Method .....	295-297
Grossman's Method .....	297, 298
Fox's Method .....	298
<b>E. VARIOUS METHODS OF LOCATING FOREIGN BODIES</b> .....	299
Screen Method .....	299
Punctograph .....	299
Rémy's Method .....	300
Barrel's Method .....	300
Shenton's Method .....	301
Harrison's Method .....	302
Leonard's Double Focus Stereoscopic Method .....	302
Triangulation Method .....	303
Grashey's Method .....	303, 304, 305

## CHAPTER IV.

## APPLICATION OF THE X-RAYS IN DISEASES OF THE THORACIC ORGANS.

	PAGE
<b>I. Fluoroscopic Examinations</b> .....	306
Anterior and Posterior Views .....	306
Lateral and Oblique Views .....	307
Methods of Examination of the Lungs .....	307
Normal Heart and Diaphragm .....	308
Measurement of the Diaphragmatic Incursion .....	308
Measurement of the Costal Angle .....	309
Causes of Restriction of the Diaphragm .....	310
Diseases of the Diaphragm .....	310
Average Normal Excursion of Diaphragm ; Width of Normal Heart .....	311
<b>II. Skiagraphic Examinations</b> .....	311
Various Positions of Patient .....	311
Time of Exposure .....	312
<b>III. Clinical Applications</b> .....	313
<b>A. DISEASES OF THE BRONCHI AND LUNGS</b> .....	313
Bronchitis ; Bronchiectasis .....	313
Asthma .....	314
Emphysema .....	315
Broncho-Pneumonia .....	315
Pulmonary Tuberculosis .....	315-318
Cavitation .....	318, 319
Acute Miliary Tuberculosis .....	319
Pneumonia .....	320
Atelectasis .....	320
Abscess and Gangrene .....	321
<b>B. DISEASES OF THE PLEURA</b> .....	321
Pleurisy with Effusion .....	321
Empyema .....	322
Pneumothorax ; Hydro-pneumothorax and Pyo-pneumothorax .....	323
Subphrenic Abscess ; Tumors of the Thorax .....	323
Enlarged Glands .....	324
<b>IV. Applications of the X-Rays to the Circulatory System</b> .....	324
<b>A. FLUOROSCOPIC EXAMINATION OF THE NORMAL HEART</b> .....	324
The Orthodiagraph .....	325-328
<b>B. SKIAGRAPHIC EXAMINATION OF THE HEART</b> .....	328
Size and Measurement of the Heart ; Cardiac Mobility .....	329
Displacement .....	330
Cardiac Atrophy, Hypertrophy, and Dilatation .....	331
Examination of the Heart .....	332
Pericarditis (Pericardial Effusion) .....	332
Aortic Aneurism .....	333
Dilatation of the Aorta ; Displaced Aorta ; Enlarged Glands ...	335
Neoplasms ; Pulsating Empyema ; Atheroma .....	335

## CHAPTER V.

## APPLICATION OF THE X-RAYS IN DISEASES OF THE ABDOMINAL ORGANS.

	PAGE
<b>I. Alimentary System</b> .....	336
<b>A. ESOPHAGUS</b> .....	336
Stricture; Stenosis .....	336
Diverticulum; Tumors.....	337
<b>B. STOMACH: SIZE, SHAPE, AND POSITION</b> .....	337
Examination by the Aid of Gaseous Distention.....	337
Mechanical Method .....	337
Bismuth Subnitrate Method.....	338
Fluoroscopic and Skiagraphic Examinations of Stomach.....	338
Time of Exposure.....	339, 340
Transillumination.....	341
<b>C. THE CLINICAL APPLICATION OF THE RAYS</b> .....	342
Behavior of the Stomach during Digestion.....	342
Position of the Stomach.....	342
Gastroptosis .....	343
Stenosis of the Pyloric End.....	344
<b>D. INTESTINES</b> .....	344
Sounding and Radiography of the Large Intestine.....	344
Obstruction .....	345
Rectal Imperforation .....	345
Abdominal New Growths .....	346
<b>E. LIVER</b> .....	346
Size and Location .....	346
Biliary Calculi .....	346, 347
<b>F. PANCREAS</b> .....	348
<b>G. SPLEEN</b> .....	348
<b>II. The Genito-Urinary System</b> .....	349
<b>A. ORDINARY METHODS; DIFFICULTIES</b> .....	349, 350
<b>B. CALCULI: their Specific Gravity, Penetrability, and Density</b> .....	350
Hypertrophy; Atrophy.....	351
Hydronephrosis and Pyonephrosis .....	351
<b>C. TECHNIC OF RENAL SKIAGRAPHY</b> .....	352
Preparation of Patient .....	352
Literature of Renal Calculi .....	352-354
Advantages and Defects of this Method .....	355
<b>D. URETERAL CALCULI</b> .....	355
Reports of Cases.....	355-359
<b>E. THE BLADDER</b> .....	359
Examination for Calculi .....	359
Closure of the Bladder, as shown by X-Rays .....	360
<b>F. PROSTATIC CALCULI</b> .....	360, 361



## CHAPTER VI.

## APPLICATION IN THE SPECIALTIES.

	PAGE
<b>I. Obstetrics and Gynæcology</b> .....	362
Pelvimetry .....	362
Skiagraph of Fœtus.....	365
Skiagram of Gravid Uterus.....	366
Neoplasms .....	367
<b>II. Rhinology, Laryngology, and Otology</b> .....	367
Abscess of the Antrum and of the Frontal Sinuses .....	368
Foreign Bodies in the Larynx .....	369
Ossification of the Laryngeal Cartilages.....	369
Foreign Bodies in the Ear.....	369
Abscess of the Mastoid Process.....	369

## CHAPTER VII.

## APPLICATION IN DENTISTRY.

<b>I. Apparatus Used.</b> .....	370
<b>II. Technic</b> .....	370
Intra-Oral .....	370
Extra-Oral or Buccal ; Tousey's Method.....	371
<b>III. Clinical Applications.</b> .....	372
Unerrupted Teeth.....	372
Necrosis of the Maxilla.....	372
Ankylosis of the Inferior Maxillary Articulation.....	373
Fracture of the Inferior Maxillary Bone .....	373
Broken Instruments ; Root-Canal Fillings ; Abscess of the Antrum.....	373
Alveolar Abscess ; Orthodontia .....	374

## CHAPTER VIII.

## THE RONTGEN RAYS IN FORENSIC MEDICINE.

<b>I. Legal Status of the X-Rays</b> .....	375
A. ADMISSIBILITY IN VARIOUS STATES.....	375-377
B. TECHNIC OF MEDICO-LEGAL SKIAGRAPHY.....	377, 378
C. HOW THE SKIAGRAPHER SHOULD PREPARE FOR COURT .....	378-382
<b>II. The Physician's Responsibility in Cases of X-Ray Burn</b> .....	382-387
Medico-Legal Aspect of Sterility .....	387, 388

## PART III.

## RADIOTHERAPY, RADIUM, AND PHOTOTHERAPY.

## CHAPTER I.

## ACTION OF THE X-RAYS ON BACTERIA.

Experiments of Numerous Operators.....	389-395
--	---------

## CHAPTER II.

## HISTOLOGICAL CHANGES INDUCED BY THE ACTION OF THE X-RAYS.

	PAGE
I. X-Ray Dermatitis .....	395, 398
A. CAUSES OF X-RAY DERMATITIS.....	398, 399
B. CLASSIFICATION OF X-RAY DERMATITIS .....	399
C. LATENT STAGE; FREQUENCY AND SUSCEPTIBILITY IN X-RAY DERMATITIS.....	401-404
D. PATHOLOGICAL PHYSIOLOGY.....	404-406
E. DURATION OF CHRONIC DERMATITIS.....	406
F. PREVENTIVE MEASURES AGAINST X-RAY DERMATITIS .....	407, 408
G. TREATMENT OF X-RAY DERMATITIS.....	408-412
II. Remote and Indirect Action of X-Rays.....	412
STERILITY .....	412-414

## CHAPTER III.

## CHANGES INDUCED IN VARIOUS DISEASED TISSUES BY THE RÖNTGEN RAYS. 415-420

## CHAPTER IV.

## TECHNIC OF RÖNTGEN RAY THERAPY.

I. Apparatus and Method of Treatment .....	420-422
CROOKES TUBE .....	422
PROTECTION OF HEALTHY PARTS.....	422-423
POSITION OF THE TUBE; DISTANCE OF THE TUBE.....	424
DURATION OF EACH EXPOSURE; FREQUENCY OF THE EXPOSURE .....	425
FILTERS; THE DOSAGE .....	426
II. Methods of Measuring X-Ray Dosage .....	427
A. MEASUREMENT OF THE ELECTRIC CURRENTS.....	427
The Current going to the Primary Coil.....	427
Milliamperage of the Secondary Induced Current.....	427, 428
Spintermeter .....	429
B. THE PENETRATION METHOD .....	429
The Radiochromometer of Benoist.....	429-431
Skiameters and Penetrometers; Cryptoradiometer of Wehnelt..	431
C. THE PHYSICO-CHEMICAL METHOD.....	431
Chromoradiometer of Holzknacht.....	432
Radiometer of Sabouraud and Noiré.....	432, 433
Chromoradiometer of Bordier.....	433, 434
Quantimeter of Kienböck.....	434
New Radiometer of Freund.....	435
Precipitation Test .....	436
D. THE IONIZATION METHOD .....	436
Ionization of Confined Gases .....	436
The Radio-active Standard of Phillips .....	437

	PAGE
E. THE PHOTOMETRIC METHODS.....	438
The Radiometer, of Courtade.....	438
The Guilleminot-Courtade Method.....	438
The Fluorometer.....	438
The Method of Contremoulins.....	439
Selenium Photometer.....	439, 440
Fluorescence of the Tube and the Appearance of the Electrodes.....	440
The Thermometric Method.....	441
III. Natural Fluorescence in the Human Organism and its Artificial Production.....	441
APPLICATION IN DISEASE.....	442, 443
Influence of Photodynamic Substances on the Action of X-Rays.....	443
CHAPTER V.	
THERAPEUTIC VALUE IN DISEASE.	
I. Cutaneous Affections.....	444
LUPUS ERYTHEMATOSUS.....	444
LUPUS VULGARIS.....	444, 445
NEVUS.....	446
ALOPECIA AREATA; Parasitic Alopecia.....	447
HYPERTRICHOSIS.....	447-449
FAVUS AND TINEA TONSURANS.....	449-451
ECZEMA.....	451, 452
ACNE.....	452
Acne Vulgaris.....	453
Acne Rosacea.....	453, 454
SYCOSIS.....	454, 455
PRURITUS ANI AND PRURITUS VULVÆ.....	455
XERODERMA PIGMENTOSUM.....	455
PSORIASIS.....	456, 457
SENILE LEG ULCERS; VARICOSE VEINS.....	457
HYPERIDROSIS.....	458
KRAUROSIS VULVÆ.....	458
LEPROSY.....	459
II. Malignant Growths.....	460
A. EPITHELIOMA.....	460-464
B. CARCINOMA.....	464, 465
Cancer of the Breast.....	465-469
Cancer of the Sternum; Cancer of the Oesophagus.....	469
Cancer of the Larynx.....	470
Cancer of the Stomach and Bowels.....	470
Cancer of the Uterus.....	470, 471
Therapeutic Action of the X-Rays in Cancer.....	471-473
C. SARCOMA.....	473-477
III. Constitutional Diseases.....	477
A. TUBERCULOSIS.....	477-482
B. LEUKEMIA.....	482-487

	PAGE
IV. Miscellaneous Affections .....	487-497
A. TRACHOMA .....	487-489
B. KELOID .....	489, 490
C. EXOPHTHALMIC GOITRE .....	490-492
D. HYPERTROPHIED PROSTATE .....	492
E. ANALGESIC ACTION OF THE RAYS .....	493-495
NEURALGIA .....	493
F. EPILEPSY .....	495-497

## CHAPTER VI.

## RADIUM AND OTHER RADIO-ACTIVE SUBSTANCES.

OCCURRENCE .....	498
CHEMICAL AND PHOTOGRAPHIC EFFECTS .....	498-500
PHYSICAL PROPERTIES OF RADIUM .....	500
Penetration; Fluorescence and Luminosity .....	500
THEORETICAL CONSIDERATIONS: CLASSIFICATION .....	501
BIOLOGICAL EFFECTS .....	501
Bactericidal Action .....	501
Influence of Radium on Agglutination; Physiological Action ..	502
Effects on the Nervous System; Effects on the Eye .....	502
RADIUM AND THORIUM AS THERAPEUTIC AGENTS .....	503
Diseases of the Skin .....	503
Mode of Retrogression of Cancer Metastases under Radium Rays,	504
Reports of Various Radium Therapeutists .....	505-507
Exophthalmic Goitre; Rabies; Nævus .....	507
Radio-active Treatment with Thorium .....	508
Rheumatism ..	509

## CHAPTER VII.

## PHOTOTHERAPY.

COMPOUND NATURE OF LIGHT .....	510, 511
ACTION OF LIGHT ON PLANTS .....	511
ACTION OF LIGHT ON BACTERIA .....	511, 512
EFFECT OF LIGHT ON ANIMALS AND MAN .....	512
THERAPEUTIC ACTION OF LIGHT; ITS USE AMONG THE ANCIENTS .....	513
TREATMENT WITH SUNLIGHT .....	514
TREATMENT WITH THE INCANDESCENT ELECTRIC LIGHT .....	514, 515
TREATMENT WITH THE CONCENTRATED ARC LIGHT .....	515, 516
THE DERMO OR IRON ELECTRODE LAMP .....	516
THE COOPER-HEWITT MERCURY-VAPOR LAMP .....	516, 517
THE FINSSEN OR RED-LIGHT TREATMENT OF SMALLPOX .....	517-520
Conditions for Success by Finsen's Method .....	520
BLUE LIGHT .....	520
Blue Light as an Anæsthetic .....	520, 521

## APPENDIX :

TECHNIC OF RÖNTGEN RAY TREATMENT .....	522
--	-----



# ILLUSTRATIONS

---

FIG.	PAGE
1. Electric units illustrated by means of the hydraulic analogy (Hedley).....	35
2. Connection of battery cells in "series".....	40
3. Connection of the cells in "parallel".....	40
4. Connection of the cells in "groups".....	41
5. Diagrammatic view of the <i>inner</i> construction of a storage cell (American Battery Co.).....	41
6. Diagrammatic view illustrating the charging of a battery by the ammeter and volt-meter.....	43
7. Diagrammatic view illustrating the charging of a battery by a bank of lamps	44
8. Diagrammatic view illustrating the principles of influence and accumulation of static or influence machines.....	47
9. Diagrammatic illustration of the theory of action of a Wimshurst influence machine.....	48
10. Wimshurst influence machine.....	49
11. Toepler-Holtz influence machine.....	50
12. Static-disk electrode with insulated points.....	53
13. Static massage electrodes for wet applications.....	53
14. Universal hard-rubber handle for holding electrodes.....	53
15. Insulated hook for holding conducting cord.....	53
16. Pole changer of Betz.....	56
17. Static breeze, concentrated brush discharge, or spray..... facing	56
18. Static negative insulation or static bath..... facing	56
19. Direct spark..... facing	56
20. Indirect spark..... facing	57
21. Friction-spark treatment.....	58
22. Static induced current..... facing	59
23. Galvanic cell.....	62
24. Bunsen cell (double fluid).....	63
25. Wall cabinet for galvanic, faradic, and sinusoidal currents.....	65
26. Deprez-D'Arsonval galvanometer (milliamperemeter).....	67
27. Galvanic, faradic, cautery, and diagnostic lamp battery.....	69
28. Medical induction coil.....	72
29. Galvanic and faradic lamp controller.....	73
30. Peterson's cataphoric electrode.....	76
31. Sectional view of the same.....	76
32. Three varieties of cataphoric electrodes.....	76
33. Martin's cataphoric electrode.....	76
34. The four-celled battery of Schnée.....	78
35. Diagrammatic view of the direction of current as is illustrated in Schnée's four-celled battery.....	79
36. Motor points of the arm.....	82
37. Motor points of the forearm and hand.....	82
38. Motor points of the arm (front view).....	83

FIG.	PAGE
39. Motor points of the forearm and hand (front view).....	83
40. Motor points of the thigh.....	84
41. Motor points of the leg and foot.....	84
42. Motor points of the thigh and leg (posterior view).....	86
43. Motor points of the leg and foot (inner side).....	86
44. Motor points of the head and neck.....	87
45. Motor points of the chest and abdomen.....	87
46. Interrupting needle-holder for electrolysis.....	100
47. Roller electrode with insulated points for muscular faradization.....	103
48. Double rectal bulb electrode.....	111
49. Shoemaker's prostatic electrolyzer.....	114
50. Vesical electrode for hydro-electric application to the female bladder.....	123
51. Goelet's intra-uterine electrode.....	123
52. Ozone inhalation.....	facing 128
53. Curved sponge electrode for application to throat.....	129
54. Electrode for hydro-electric application, post-nasal and pharyngeal.....	129
55. Double sponge-tipped ear electrode.....	131
56. Adjustable eye electrode, for one or both eyes.....	136
57. Oscillatory nature of the Leyden-jar discharge.....	139
58. Morton's "static-induced current" high-frequency apparatus.....	140
59. D'Arsonval high-frequency apparatus.....	141
60. The Tesla transformer.....	142
61. Diagram of the Oudin resonator.....	facing 142
62. The Oudin resonator and Tesla coil, with electrode.....	facing 142
63. Glass electrodes.....	facing 143
64. Piffard's glass electrode.....	144
65. Morton's cataphoric electrode.....	144
66. Treatment by auto-conduction.....	facing 148
67. Treatment by the effluvia method.....	facing 149
68. Diagram illustrating the principles of induction (after Donath).....	170
69. Self-starting interrupter.....	facing 172
70. Diagrammatic view of self-starting interrupter (Röntgen Manufacturing Co.).....	facing 172
71. Mercury interrupter.....	173
72. Davidson's interrupter.....	facing 174
73. Johnston's mercury interrupter.....	facing 174
74. Wehnelt interrupter.....	175
75. Simon interrupter.....	176
76. Friedlander electrolytic interrupter.....	177
77. The Tesla oscillator.....	180
78. Outer view of the same.....	180
79. Lines of force in the older coils.....	182
80. Lines of force in Kinraide's coil.....	182
81. Kinraide's diagram of two coils side by side.....	183
82, 83. Discharge passing through low-vacuum tubes (Bouchard).....	186
84. Cathode rays (Bouchard).....	186
85. Deflection of the cathode rays (Bouchard).....	186
86. Illustration of the effect of one cathode and several anodes under different degrees of vacuum (Bouchard).....	187
87. Illustration of one of the phenomena in high vacua,—the rectilinear propagation of the cathode rays (Bouchard).....	187

## ILLUSTRATIONS.

XXV

FIG.	PAGE
88. Essential features of an X-ray tube.....	188
89. Queen's self-regulating tube.....	191
90. Müller's regulation tube.....	192
91. Monopol tube.....	193
92. Osmosis regulating tube of Gundelach.....	194
93. Self-regulating X-ray tube, operating properly..... facing	194
94. Self-regulating X-ray tube, current running in wrong direction..... facing	196
95. Villard's ventril tube.....	198
96. Self-regulating X-ray tube, low vacuum..... facing	198
97. Self-regulating X-ray tube, punctured or cracked, bulb partially filled with air..... facing	200
98. Ordinary diaphragm.....	203
99. Tubular or compression diaphragm (Donath).....	203
100. Author's table and tube-holder.....	205
101. Diagrammatic view of the installation of the "jumbo" coil and its connections with the variable primary coil, as used by the author at the Philadelphia Hospital.....	206
102. Author's office outfit.....	207
103. Polarity as determined by the appearance of the spark.....	208
104. Detachable fluoroscope and screen.....	211
105. A study in shadow distortions (fluoroscopic or skiagraphic) with correspond- ing density difference.....	212
106. Envelo developer (Lyon Camera Co.)..... facing	226
107. Automatic tray-rocker (Röntgen Manufacturing Co.)..... facing	226
108. Author's washing tank.....	228
109. Author's negative-viewing box.....	236
110. Principles of Brewster's refracting stereoscope.....	243
111. Principles of Wheatstone's reflecting stereoscope.....	243
112. Technic of stereo-skiagraphy, and viewing by reflection and refraction.....	245
113. Author's plate-changing box.....	246
114. Wheatstone's reflecting stereoscope, as modified by Weigel..... facing	250
115. Prism stereoscope of Walter.....	250
116. Stereo-skiagrams of Colles's fracture..... facing	250
117. Inward dislocation of the first phalanx of the thumb..... facing	262
118. The normal hand, taken with high-vacuum tube..... facing	262
119. Fracture of the scaphoid..... facing	262
120. Colles's fracture (antero-posterior view)..... facing	262
121. Colles's fracture (lateral view)..... facing	262
122. Fracture of the styloid process of the ulna (supine position)..... facing	263
123. The same (prone position)..... facing	263
124. Typical Colles's fracture..... facing	263
125. Green-stick fracture of the ulna..... facing	266
126. Fracture of the neck of the radius..... facing	266
127. Epiphyseal separation and displacement of the lower end of the humerus facing	266
128. Fracture of the ulna and displacement of the head of the radius..... facing	266
129. Supracondyloid fracture of the humerus..... facing	266
130. Fracture of part of inner epicondyle, after forcible reduction..... facing	266
131. Detachment of a portion of the external condyle of the humerus (antero- posterior view)..... facing	266
132. The same, in the lateral view..... facing	266



FIG.	PAGE
133. Detachment of the supinator longus muscle.....	facing 266
134. Epiphysitis of the humeral head.....	facing 266
135. The corresponding normal side.....	facing 266
136. Subluxation of the shoulder-joint.....	facing 266
137. Fracture of the acromion process.....	facing 266
138. Fracture of the acromial end of the clavicle.....	facing 266
139. Fracture of the metatarsal bones.....	facing 267
140. Fracture of the middle of the fourth metatarsal bone.....	facing 270
141. Pott's fracture.....	facing 270
142. Fracture of tibia and fibula, taken at an angle between the antero-posterior and lateral positions.....	facing 270
143. The same, in the lateral view.....	facing 270
144. Fracture of the anterior portion of the patella.....	facing 270
145. Detachment of the tubercle of the tibia.....	facing 270
146. Incomplete inter-trochanteric fracture.....	facing 270
147. Congenital dislocation of the head of the left femur.....	facing 270
148. Congenital dislocation of both hips.....	facing 270
149. Pathological dislocation of left hip in a child.....	facing 270
150. A case of probable infantile palsy.....	facing 271
151. Chronic osteitis with eburnation.....	facing 274
152. Osteitis of the index finger.....	facing 274
153. Tuberculous osteitis.....	facing 274
154. Syphilitic osteitis of the radius.....	facing 274
155. Necrosis of the os calcis.....	facing 274
156. Supernumerary thumb.....	facing 274
157. Congenital absence of the ulna and two fingers.....	facing 275
158. Congenital multiple exostoses.....	facing 275
159. Delayed ossification of the epiphyses.....	facing 276
160. Author's head rest.....	278
161. Tuberculous arthritis of the knee-joint.....	facing 284
162. Coxa vara.....	facing 284
163. Arthropathies in the knee-joint.....	facing 284
164. Penny in the œsophagus.....	facing 285
165. Principles of the method of localization (Sweet).....	291
166. Indicating apparatus secured to the side of the head (Sweet).....	292
167. Outline drawing of radiograph, tube above the plane of indicators.....	293
168. Outline drawing of radiograph, tube below the plane of indicators.....	293
169. Sweet's chart for plotting location of foreign bodies in the eye.....	294
170. Mackenzie Davidson's localizer.....	295
171. Fox's localizer.....	facing 298
172. The right-angle method of localization.....	299
173. "T" scale used in the triangulation method.....	304
174. Scheme of application of the "T" scale.....	304
175. Orthodiagraphic localizer of Grashey.....	305
176. Diagrammatic view of the same.....	305
177. Tuberculosis of the right lung (posterior view).....	facing 318
178. Tuberculosis of the right lung (anterior view).....	facing 319
179. Moritz' orthodiagraph (horizontal position).....	facing 324
180. Moritz' orthodiagraph (vertical position).....	facing 324
181. Levy-Dorn's orthodiagraph for the standing position.....	327
182. Levy-Dorn's orthodiagraph for use in the recumbent posture.....	328



FIG.	PAGE
183. Author's table for skiagraphing the heart and lungs.....	facing 328
184. The same when used in the sitting position.....	facing 329
185. Aneurism of the descending aorta.....	facing 334
186. Tracing of the same.....	facing 334
187. Dilatation of the heart, with aneurism of the aorta.....	facing 335
188. Atheroma of the femoral artery.....	facing 335
189. A case of gastropsois (bismuth emulsion method).....	facing 344
190. Reid's apparatus for renal skiagraphy.....	356
191. Clock arrangement and break of the same.....	357
192. Compression diaphragm of Albers-Schönberg (Kny-Scheerer Co.).....	358
193. The same, postero-anterior view (Kny-Scheerer Co.).....	359
194. Calculus in the pelvis of the right kidney.....	facing 360
195. Vesical calculus.....	facing 361
196. Varnier's arrangement for radiography.....	364
197. Author's head rest for stereoscopic work.....	366
198. Author's head rest for skiagraphing diseases of the frontal sinuses.....	368
199. Tumor in the trachea.....	facing 368
200. Extra-oral method in dental skiagraphy.....	facing 372
201. Unerupted teeth.....	facing 372
202. Unerupted upper cuspid tooth.....	facing 372
203. Delayed eruption of the upper cuspid tooth.....	facing 372
204. Delayed eruption of the upper cuspid tooth with the temporary teeth <i>in situ</i>	facing 372
205. Delayed second bicuspid, right side of lower jaw.....	facing 372
206. Delayed second bicuspid, left side of lower jaw.....	facing 372
207. Phosphorous necrosis of the inferior maxilla.....	facing 373
208. Chronic alveolar abscess of the right central incisor tooth.....	facing 373
209. Author's hands, showing result of chronic X-ray dermatitis.....	facing 400
210. Author's scheme for the operator's protection.....	408
211. Piffard treatment tube.....	421
212. The bi-cathode tube of Koch of Dresden.....	421
213. The Kny-Scheerer tube.....	421
214. Rosenthal's tube for therapeutics.....	422
215. Connection of the tube and Villard valve with the oscilloscope.....	423
216. Benoist's radiochromometer.....	430
217. The improved Benoist radiochromometer as modified by Pfahler (Röntgen Manufacturing Co.).....	facing 430
218. The same, with its parts connected (Röntgen Manufacturing Co.).....	facing 430
219. The skiameter.....	facing 430
220. Crypto-radiometer of Wehnelt.....	431
221. Kienböck's quantimeter.....	435
222. Profile and full view of a patient with acne rosacea.....	facing 456
223. The same, after fifty irradiations.....	facing 456
224. Epithelioma of the nose, before irradiation.....	facing 456
225. The same, after irradiation.....	facing 456
226. Epithelioma of fifteen years' standing, treated by irradiation, and in which radium therapy was employed as a control test.....	facing 456
227. Epithelioma of the dorsum of the hand, before irradiation.....	facing 457
228. The same, after irradiation.....	facing 457
229. Tubes and rubber tube shields for therapy of the body cavities (R. V. Wag- ner Co.).....	471

FIG.	PAGE
230. Pennington's treatment [cavity] tube (R. V. Wagner Co.).....	472
231. Cavity tube applied (R. V. Wagner Co.).....	472
232. Sarcoma of the leg.....facing	476
233. Skiagraph of the same.....facing	476
234. Tuberculosis of the skin.....facing	488
235. The same, after irradiation.....facing	488
236, 237, 238. Groups of patients irradiated for epilepsy.....facing	489
239. Hartigan's radium applicator.....	508
240. Shober's radiode.....	509
241. Solar spectrum, showing the scheme of wave lengths of different radiations..	510
242. Cabinet for the treatment of disease by the employment of incandescent lights (Kny-Scheerer Co.).....facing	514
243. The Finsen method of treatment.....facing	515
244. The dermo or iron electrode lamp.....	516
245. Photograph of the late Professor Niels R. Finsen.....facing	518
Röntgen ray treatment chart.....facing	526

# INTRODUCTION

---

## HISTORICAL SKETCH OF THE RISE OF ELECTRICITY

IN the remotest periods of the world's history, when legend, myth, and fact were inseparably connected, the phenomena of electricity were regarded as symbolic of some special deity and formed the basis of a national faith. The philosophers of Greece would bow in veneration at the sound of the thunderbolt, and in Rome the ominous herald of the storm would silence the orator in the Forum. Indeed, to enumerate the meanings and the attributes ascribed to the lightning flash and to the reverberating thunder would be to rewrite a lengthy and absorbing chapter from the pages of mythology.

But in the midst of all this myth and superstition,—this era of the legendary period,—arose Thales of Miletus, whose profound knowledge of science and metaphysics had challenged the admiration of the famous Phœnician voyagers. These intrepid navigators were accustomed to sailing the straits of Hercules in order to reach the Baltic Sea, and from its desolate waters they would seize a delicate substance, fair in color, and beautiful in transparency. To Thales this strange creation of nature had mysterious properties. He named this precious find *electron* or amber, and he blazed the way for future knowledge in discovering that when *electron* was rubbed it possessed the property of attracting to itself various light articles. Three hundred years later Theophrastus enlarged upon the teaching of Thales and conferred the name of “animated gem” upon this beautiful product of the northern seas. Pliny followed with other learned dissertations; and thus through ages the mysterious *electron* confounded the minds of philosophers, never once intimating that the secrets hidden in its delicate transparent substance were the secrets of Indra, the Jupiter of the Hindoos, or the terrible weapon of Jupiter Tonans defiantly passing over suppliant Rome. Centuries passed. Kingdoms arose and nations disappeared, but the studies of Thales were never forgotten. Not till the dawn of the sixteenth century was the subject again brought forward upon a scientific basis. In 1590 Gilbert's work “*De Magnete*,” having for its keynote the words: “*Magnus magnes ipse est globus terrestris*,” appeared in England, and the discoveries made by this new champion confused and terrified its readers. The supernatural seemed to envelop its pages; the printed words breathed of the spiritual. Sparks and flames, shocks and strange sensations, pranced and



teased the hands and bodies of hundreds of experimenters, and the masses of the people were almost unanimous in declaring that *electron* was invested with a soul. Although Physician in Ordinary to Queen Elizabeth, Gilbert did not attempt to apply the knowledge thus gained to medicine. His friend, the poet Dryden, immortalized him in the following lines :

“ Gilbert shall live till lodestones cease to draw  
Or British fleets the boundless ocean awe.”

Such was the birth of the science of electricity.

But the magnificent generalization made by Gilbert was but the initial step ; the scientifically inquisitive Otto von Guericke of Magdeburg quite promptly gave to the world a machine for generating electricity, as useful at that period as was his indispensable air-pump. It remained, however, for Stephen Gray, in 1730, to disclose the secrets so deeply hidden in this mysterious substance, and it was he who expounded the leading principles of the science of electricity. Amazed at the wondrous achievements attained by these later philosophers, Du Fay and Nollet in France assiduously applied themselves to a study of electrical phenomena. Du Fay suspended himself by a silken cord, and was then filled with electricity by Nollet ; he presented his hand to his companion, when a brilliant spark shot from hand to hand, a phenomenon that completely baffled the minds of both these scientists.

Shortly after this the whole of Europe was awe-struck by the invention of the Leyden jar. Professor Musschenbroek received its first full discharge, and he wrote to Réaumur that he would not suffer a second such shock for the whole kingdom of France. Seizing upon this famous discovery, Franklin in America invented a battery of jars capable of giving shocks quite analogous to the terrifying powers of the thunderbolt. It was Franklin's contention that the electricity of the earth and air was one, and it was this positive conviction that awakened the derision and evoked most painful sarcasm from the Royal Society of London. Not dismayed by this adverse criticism, the persistent American philosopher constructed a silken kite containing an iron point. Attached to the kite was a hemp string ending in a silken cord ; to the latter was hung an iron key. He selected a rainy day in June, 1752, for the experiment. Stationing himself on what is now known as Ridge Avenue and Green Street, in Philadelphia, Franklin flew his curious apparatus to the breeze. Suddenly the falling rain made the hemp string an excellent conductor, the fibres were stirred as by a strange impulse ; he applied his hand to the key and at once drew sparks from its sides. He felt that he had triumphed : he had seized the vagrant lightning of the storm ! The Royal Society of London realized that a mighty scientific achievement had been wrought, and made him a member and awarded him their

greatest prize, and he was signally honored in Germany, France, and Russia.

During the eighteenth century, the science of electricity became one of the most important and interesting branches of knowledge. In 1790 Galvani, through the convulsive movements of a dead frog, hanging from an iron balcony, brought forward his great discovery of galvanism. The immortal Volta improved upon Galvani's teachings. With the introduction of the voltaic pile, in 1800, his fame spread world-wide, by later modifications he formed the beautiful "La Couronne de Tasses," the model by which to-day we flash our messages through the fathomless oceans. It was more than one hundred years after Gilbert's time, that electricity was first brought into use as a curative agent. De Haen (1745), Jallabert (1748), and Abbé Nollet (1749) were the first to employ static electricity in medicine. In 1758 Benjamin Franklin tried the action of the electric current on a number of paralytics. In 1759 the Reverend John Wesley, the famous divine, published a treatise entitled *The Desideratum, or Electricity made Plain and Useful, by a Lover of Mankind and Common Sense*. The first records of electrical treatment at a London hospital are found in the year 1767, when a static machine was installed at the Middlesex Hospital, and in 1777 another was placed in St. Bartholomew's Hospital. At St. Thomas's Hospital the subject was systematically pursued by Mr. John Birch, the surgeon; and in 1799 he contributed an essay of fifty pages on medical electricity to John Adams's book, *An Essay on Electricity*. The nineteenth century has seen the fruits of these great labors practically applied. To enumerate even a tithe of the marvellous discoveries and inventions that form part of our conveniences, of our necessities, of integral parts of our everyday lives, would be merely to repeat an oft-told story—a story of the great triumphs of human achievement.

## ELECTRICITY AS A PART OF THE MEDICAL CURRICULUM

It has been estimated that about 12,000 physicians are constantly using some form of electricity in their daily practice. The question naturally arises, Why doesn't the subject of medical electricity form part of the college curriculum? Without some theoretical and practical knowledge of the science, how can the physician hope to apply a current intelligently or know when its application is advantageous? Is not this ignorance of its principles and practical workings responsible for its being classed in the charlatan's armamentarium and its administrator designated a quack? To understand medical electricity the tyro must begin in the laboratory. He must there study the physics of electricity and magnetism; he must study electrical appliances for creating energy.



Besides these things he should diligently inquire as to the resistances encountered in the human body, the electrolysis resulting in living tissues, the range of voltage, etc. He needs to be trained especially in what may be termed the physiological action of the various currents and their therapeutic values. Indeed, if but one hour daily for a single term be devoted to the study of the mechanism of the apparatus, to the connection of the wires, the nature of the current, etc., and a corresponding limited number of hours be devoted in a succeeding term to the therapeutic application of the science, it is more than likely that a correct appreciation of the study will be meted out to it, and the professed specialists who are now duping the unwary would be forced to retire ignominiously from the field.

# PRACTICAL ELECTRO-THERAPEUTICS

---

## PART I ELECTRO-THERAPEUTICS

---

### CHAPTER I

#### THE ELEMENTARY PRINCIPLES OF ELECTRICITY AND MAGNETISM.

IN the following paragraphs an effort has been made to present, in a space succinct yet commensurate with the importance of the subject, the underlying principles of electricity and magnetism, embracing the more usual terms, tables of units, sources of energy, and the fundamentals of the science necessary to an understanding of its application to medicine and surgery. Clearness of expression has been aimed at rather than a detailed scientific and mathematical exposition of every term employed. Those interested in a more elaborate study of these principles are referred to the standard works on natural philosophy and electricity.

#### I. Nature and Properties of Magnetism.

The nature of magnetism is more or less closely allied to that of electricity. The term "magnet" is supposed to originate from the Greek word "Magnesia," a principality of ancient Greece, where deposits of magnetite were first discovered. Chemically this is known as magnetic iron ore ( $\text{Fe}_3\text{O}_4$ ).

Magnets are of two kinds :

- (a) *Natural*,
- (b) *Artificial*.

Experiments have demonstrated that, when steel bars are applied to lodestones or other magnets, they become magnetized, and the original magnet suffers no loss of magnetic property. Magnets made in this manner are called "artificial magnets." The original lodestones, from their inherent magnetic properties, are designated "natural magnets." Chemically the substance is known as "magnetite."

Magnetism may be temporary or permanent. Temporary magnetism is magnetism remaining only for a short time, as in soft iron.

Permanent magnetism, as the name indicates, permanently resides in the magnet, as in steel.

#### ELECTRO-MAGNETS.

When a bar of soft iron has wound around it a coil of wire for the purpose of establishing a magnetic field, we obtain an electro-magnet. Soft iron is almost universally employed in the manufacture of electro-magnets. The use of hard steel with a similar strength of current yields far less magnetic force.

## II. Nature and Properties of Electricity.

*Electricity* (derived from the Greek *ἤλεκτρον*, amber) is the term applied to a certain invisible agent known to us only through its peculiar behavior. The early scientists held that electricity was a fluid; later experiments tended to show that it behaved like an incompressible liquid, and in other ways resembled a gas highly attenuated and without weight. In the light of present knowledge, the fluid theories have been abandoned, and it is now generally accepted that the peculiar phenomena are the result of some strain or other action in the ether, the latter being supposedly a fluid medium that exists in all parts of the universe—in gases, solids, and liquids.

### A. THEORY OF POTENTIAL.

The laws which concern the magnitude and measurement of electrical quantities are very difficult to explain. That branch of electrical science dealing with the measurements of electrical charges is called *electro-statics*. Many of the less complicated electrical phenomena may be conveniently illustrated by the action of fluids, though it must be remembered that such comparisons are only relative, and introduced to facilitate the easy mastering of electricity. Electrical potential, or electro-motive force (written thus—E. M. F.), is that property possessed by a body by means of which an electric current is enabled to pass from it, through some other medium, into another body. In order to simplify the theory of potential, it is essential to notice the elementary laws governing electrical force.

**Hydraulic Analogy.**—In order to simplify the term “potential,” let us assume the following analogy between electricity and water. Let us suppose two reservoirs (both partly filled with water) at different levels and connected with each other by means of tubing. Evidently the water in the reservoir placed at the higher level will flow through the pipe into the lower reservoir. The flow is due to difference in levels

producing pressure (or motive force), measured by the difference in altitude (or potential) between the water contained in the two reservoirs. When the two reservoirs are placed at the same level, no difference in pressure will exist; hence, no water will flow from the one reservoir to the other. If we substitute the word "potential" for "level," we then employ the common electrical term.

Imagine two charged bodies to be connected with each other by wire; a flow of current takes place from the positive to the negative charged body; this is possible because of a difference in the potential in the two bodies. Allowing that the positive charged body is at a higher potential (or level) than the one charged negatively, we must state that the flow of

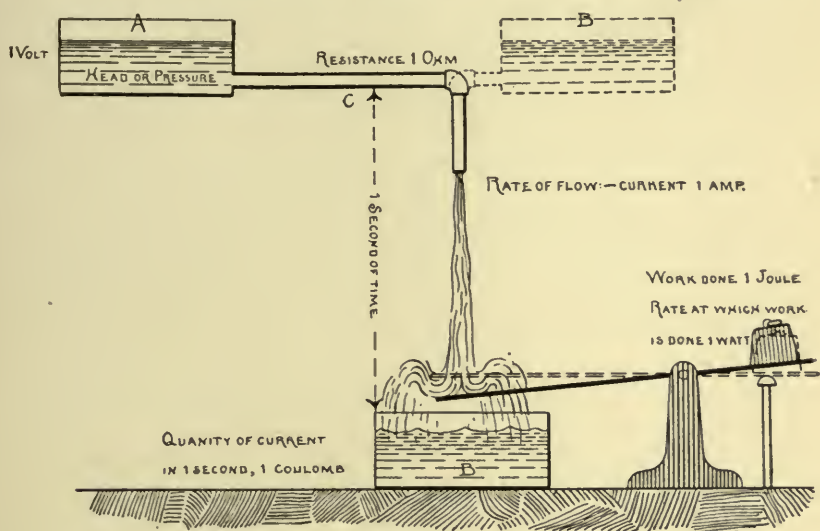

FIG. 1.—Electrical units illustrated by means of the hydraulic analogy. (Hedley.)

current results from the difference in the potentials, thus creating an electrical pressure or electro-motive force. The fact that there is a flow of current from a higher to a lower potential must not be overlooked. From the foregoing remarks it may be assumed that no flow of current takes place between the bodies when they are at equal potentials. Whenever a stream of water falls from a higher to a lower level, it will perform a certain amount of work in its course downward,—*i. e.*, it has acquired a certain amount of potential force, and, besides, the difference of level cannot be restored without expending a certain amount of work. For every pound of water that is lifted through a difference of level equal to a foot, one foot-pound of work is done, no matter what the shape of the path may be by which the elevation of the water to a higher level is accomplished. Likewise, electricity cannot be transferred from one body to



another at a higher potential without requiring a certain amount of work to be accomplished. The term potential, though relative, must be considered as meaning a force or power to do work. For instance, if we lift a one-pound body five feet high against the force of gravity, the weight of the pound-body in turn can accomplish five foot-pounds of work in falling to the ground. In the strictest sense of the term, potentials are relative; hence it is always the difference of potential with which we are dealing.

## B. UNITS OF ELECTRICAL MEASUREMENT.

**C. G. S. System.**—Electricians have universally agreed to adopt a system of measurement based upon three fundamental units: namely, the *centimeter*,—the unit of length; the *gramme*,—the unit of weight or mass; and the *second*,—the unit of time. All other units are derived from these three, and are known as *derived units*, one of the most important of these being the unit of force, called the *dyne*. The dyne is that force which when acting for one second of time on a mass of one gramme conveys to it a velocity of one centimeter per second.

(a) **Electro-static Units.**—(1) The *unit of electro-static quantity* is that quantity of electricity which, when placed at a distance of one centimeter (in the air) from a similar and equal quantity, repels it with a force equal to one dyne.

(2) The *unit of electro-static potential* is equal to the unit of work done in moving a unit of positive electricity against the electric forces.

(3) The *electro-static unit of difference of potential* is that difference existing between two points when it requires the expenditure of one erg of work to bring a positive unit of electricity from one point to the other against the electric force.

(4) The *electro-static unit of capacity* is that conductor which requires a charge of one unit of electricity to bring it up to unit potential.

(5) By *electro-motive intensity* is meant the electric force of intensity of an electric fluid at any point, being measured by the force which it exerts on a unit charge placed at that point.

(b) **Magnetic Units.**—(1) The *unit magnetic pole* is one of such a strength that when placed at a distance of one centimeter (in the air) from a similar pole of equal strength, repels it with a force of one dyne.

(2) *Magnetic potential* is measured by the amount of work done in moving a unit magnetic pole against the magnetic forces.

(3) *Unit difference of magnetic potential* exists between two points when it requires the expenditure of one erg of work to bring a unit magnetic pole from one point to the other against the magnetic forces—magneto-motive force being measured in the same units as difference of magnetic potential.



(4) The *intensity of magnetic field* is measured by the force it exerts upon a unit magnetic pole ; hence,

(5) *Unit intensity of field* is that intensity of a field which acts on a unit pole with a force of one dyne, the term *gauss* having been proposed for this unit.

(6) *Magnetic flux*, or total induction of magnetic lines, is equal to the intensity of field multiplied by area—its unit being equal to one magnetic line.

(7) *Magnetic reluctance* is the ratio of magneto-motive force to magnetic flux.

(c) **Electro-magnetic or "Absolute" C. G. S. Units.**—The preceding magnetic units give rise to the following set of electrical units, in which the strength of currents, etc., is expressed in magnetic measure, according to the centimeter-gramme-second system :

(a') A current has a *unit of strength* when one centimeter length of its circuit bent into an arc of one centimeter radius exerts a force of one dyne of a unit magnet-pole placed at the centre.

(b') *Unit of difference of potential* exists between two points when it requires the expenditure of one erg of work to bring a unit of positive electricity from one point to the other against the electric force.

(c') A conductor is said to possess a *unit resistance* when unit difference of potential between its ends causes a current of unit strength to flow through it.

(d') *Unit of quantity of electricity* is that quantity which is conveyed by unit current in one second.

(e') *Unit of capacity* requires one unit quantity to charge it to unit potential.

(f') *Unit of induction* is such that unit electro-motive force is induced by the variation of the current at the rate of one unit of current per second.

(d) **"Practical Units and Standards."**<sup>1</sup>—Several of the above 'absolute' units in the C. G. S. system would be inconveniently large and others inconveniently small for practical use. The following are therefore chosen as practical units :

"(1) *Resistance.*—The **Ohm**, =  $10^9$  absolute units of resistance (and theoretically the resistance represented by the velocity of one earth-quadrant per second) but actually represented by the resistance of a uniform column of mercury 106.3 centimeters long and 14.4521 grammes in mass at 0° C. Such a column of mercury is represented by a 'standard' ohm.

<sup>1</sup> An International Congress of Electricians met at the Columbian Exposition, at Chicago, in 1893 for the purpose of adopting practical and standard electrical units. These commissioned delegates of many countries agreed upon the following eight definitions of terms.

“(2) *Current*.—The **Ampere** (formerly called the ‘weber’), =  $10^{-1}$  absolute units; practically represented by the current which deposits silver at the rate of 0.001118 gramme per second.

“(3) *Electro-motive Force*.—The **Volt**, =  $10^8$  absolute units, is that E.M.F. which applied to 1 ohm will produce in it a current of 1 ampere; being  $\frac{10000}{14334}$  of the E.M.F. of a Clark standard cell at  $15^{\circ}$  C.

“(4) *Quantity*.—The **Coulomb**, =  $10^1$  absolute units of quantity; being the quantity of electricity conveyed by 1 ampere in one second.

“(5) *Capacity*.—The **Farad**, =  $10^{-9}$  (or one one-thousand-millionth) of absolute unit of capacity; being the capacity of a condenser such as to be changed to a potential of 1 volt by 1 coulomb. The *micro-farad* or millionth part of 1 farad =  $10^{15}$  absolute units.

“(6) *Work*.—The **Joule**, =  $10^7$  absolute units of work (ergs), is represented by energy expended in one second by 1 ampere in 1 ohm.

“(7) *Power*.—The **Watt**, =  $10^7$  absolute units of power (ergs per second), is power of a current of 1 ampere flowing under a pressure of 1 volt. It is equal to one joule per second, and is approximately  $\frac{1}{746}$  of one horse-power.

“(8) *Induction*.—The **Henry**, =  $10^9$  absolute units of induction, is the induction in a circuit when the electro-motive force induced in this circuit is 1 volt, while the inducing current varies at the rate of one ampere per second.

“Seeing, however, that quantities a million times as great as some of these, and a million times as small as some, have to be measured by electricians, the prefixes **mega-** and **micro-** are sometimes used to signify respectively ‘one million’ and ‘one millionth part.’ Thus, a *megohm* is a resistance of one million ohms, a *micro-farad* a capacity of  $\frac{1}{1000000000}$  of a farad, etc. The prefix **kilo-** is used for ‘one thousand’ and **milli-** for ‘one thousandth part’; thus, a *kilowatt* is 1000 watts, and *milliampere* is the thousandth part of 1 ampere.

“The ‘practical’ system may be regarded as a system of units derived not from the fundamental units of *centimeter*, *gramme*, and *second*, but from a system in which, while the unit of time remains the second, the units of length and mass are respectively the earth-quadrant and  $10^{11}$  grammes.”<sup>1</sup>

### C. DEFINITIONS AND EQUATIONS.

We are now prepared to follow our analogy in the comparison between the flow of water in a tube and the flow of the electric current. The first principle to demand attention is that of conductivity.

*Conductivity*.—Upon the size and construction of a pipe depends the amount of energy required to propel water through it. A pipe that has

<sup>1</sup>Elementary Lessons in Electricity and Magnetism.—Sylvanus Thompson.

a smooth inner surface conducts water more readily and with less loss of energy than one whose size is the same but has a rough inner surface. Similarly does the flow of electricity depend upon the size and material of which the conducting medium is composed. An electric current flows through the entire cross-section of a conductor, so that the resistance offered is uniform throughout the material. Different materials conduct electricity differently, so that we speak of their relative powers as their conductivities.

*Resistance: Ohm's Law.*—When forcing water through a pipe by means of pump pressure, the flowing stream is proportional to the pressure divided by the resistance. The resistance is the result of friction. This applies to an electric current, the current strength being equal to the electro-motive force divided by the resistance and inversely as the resistance of the circuit; in other words, anything that makes the E. M. F. acting in the circuit greater will increase the current, while anything that increases the resistance (either the internal resistance in the source of E. M. F. itself, or the resistance of the external wires of the circuit) will diminish the current. This is Ohm's law, and is frequently expressed thus:

$$\text{Ampere} = \frac{\text{Volt}}{\text{Ohm}} = C = \frac{\text{E. M. F.}}{R} = \text{Current} = \frac{\text{Electro-motive Force}}{\text{Resistance.}}$$

True electrical resistance depends upon the nature of the metal of which the conductor is composed, the area or diameter of its cross-section, its length, and lastly upon its temperature. "The greater the cross-section of a conductor the greater is its electrical conducting power, and therefore the less is its resistance; and the longer the wire the less is its conducting power, and therefore the greater is its resistance."

The relations of the above units may be expressed as follows:

1 volt x 1 ampere .....	= 1 watt
1 volt ÷ 1 ohm .....	= 1 ampere
1 ampere x 1 ohm .....	= 1 volt
1 ampere x 1 second x 1 ohm .....	= 1 joule
1 ampere x 1 second .....	= 1 coulomb

### III. Sources of Electrical Energy.

The energy required for producing the electric current may be derived from

A. Static	} electricity.
B. Galvanic	
C. Dynamic	
D. Thermal	

A. STATIC ELECTRICITY will be discussed in the chapter on the Röntgen-ray apparatus.



## B. THE GALVANIC CURRENT.

(a) **Primary batteries** consist of a series of cells containing a corrosive fluid, called the electrolyte, in which are two immersed dissimilar metals. The employment of the galvanic current, however, is not practical in X-ray work, owing to the necessity of employing large numbers of cells and the tedious and unpleasant labor occasioned by their use. The most reliable of these cells are the Bunsen and the Daniell. The latter cell is recognized as a standard, the pressure of one of the cells being equivalent to one volt (approximately). These cells may be connected in one of three ways :

1. In series.
2. In parallel.
3. In groups.

(1) *Series.*—In order to obtain the highest E. M. F. (voltage) it is necessary to connect the cells in "series:" in other words, the negative pole of the first cell is connected with the positive pole of the second cell, the negative pole of the second cell with the positive pole of the third cell (and so on), and the free negative and free positive poles of the first and last cells form the ends or terminals of the "battery." In such an arrangement the E. M. F. resulting is equal to the sum of the E. M. F. of the individual cells. (Fig. 2.)

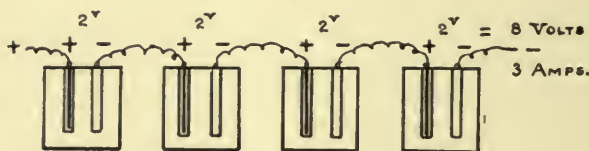

FIG. 2.—Connection of the cells in "series."

(2) *Parallel.*—In order to obtain increased current strength (amperage) the cells are connected in a manner known as the "parallel" plan (Fig. 3), thus: The positive poles of the individual cells, as well



FIG. 3.—Connection of the cells in "parallel."

as the negative, are connected in such a manner as to form one pole of the battery, positive—and the other pole, negative. In other words, by the union of the several cells in this manner one large cell has been produced. The resulting electro-motive force is the electro-motive force of one cell only, while the resistance equals that of one cell divided by

the total number of cells. The amperage is equal to the product of the number of cells by the amperage of each individual cell.

(3) *Group*.—In the “group” method some (Fig. 4) cells are joined in series and some are in parallel. Thus,—place two cells in one series, and the other two in another series; connect the positive poles of the two groups to form a positive pole, and the negative poles of the two

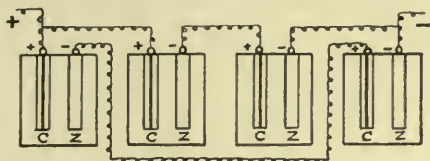

FIG. 4.—Connection of the cells in “groups.”

groups to form a negative pole,—the result of this arrangement being to halve the number of cells and thus double their size.

(b) **Accumulators, Storage or Secondary Batteries.**—In 1802 Gautherot, after laborious experiments, invented the storage battery. This was improved upon by Ritter in 1803, but the greatest improvements were introduced in 1859 by the elaborate investigations of Gaston Planté.

Briefly, the *principle* involved in the accumulator is as follows: We pass an electric current into a primary cell, containing two plates of similar metals. For this purpose, lead is almost universally employed, the chemical action from the current resulting in the production of the peroxide of lead ( $\text{PbO}_2$ ) on that sheet of lead to which the positive pole is attached, whilst the negative plate shows the formation of spongy metallic lead ( $\text{Pb}$ ). The charging current is now removed, the two plates of lead are united, and a current having the opposite direction is produced. So long as this condition is maintained a new phenomenon is observed; the peroxide of lead suffers a change, being reduced to plumbic oxide ( $\text{PbO}$ ), and the spongy lead is changed to the oxide of lead through

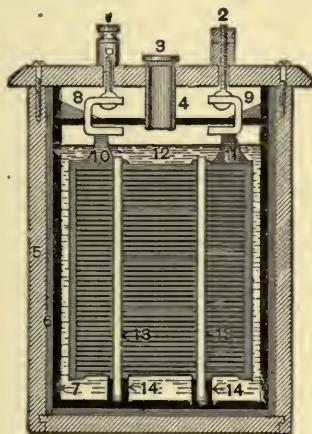

FIG. 5.—Diagrammatic view of the inner construction of a storage cell. (American Battery Company.) 1, positive binding post; 2, negative binding post; 3 rubber cap; 4, hard-rubber vent-tube; 5, oak case; 6, compound between rubber jar and oak case; 7, hard-rubber jar; 8, leaden lug attached to positive plates; 9, leaden lug attached to negative plates; 10, positive plate; 11, negative plate; 12, sulphuric-acid solution; 13, soft-rubber bands; 14, hard-rubber insulators.



the process of oxidation, until the two plates are again chemically identical; when this condition is arrived at, the current ceases. A very ingenious construction of this principle is shown in Fig. 5.

A marked improvement over Planté's accumulator is the ingenious invention of Faure. In 1881 the latter scientist perfected his invention that is now so largely employed. In the Faure system, the active material is previously prepared and spread on a suitable support or grid—mostly of lead—in such a manner that it is well retained, which offers little electrical resistance. For the positive plates, use is made of red lead ( $\text{Pb}_3\text{O}_4$ ) and sulphuric acid (50%); for the negative plates, either litharge ( $\text{PbO}$ ) and sulphuric acid or porous lead.

Other advantages to be gained in the employment of the accumulator are :

1. Its high E.M.F. (2 volts for each cell).
2. Its compactness, portability, and durability.

The *capacity* of an accumulator is usually expressed in "ampere-hours," implying the product of maximum discharging current together with the length of time in hours it discharges. The capacity will be slightly reduced when an accumulator discharges for a very short length of time at a higher rate than the maximum discharge current; the capacity depending upon the size, the number of plates and their formation. For illustration, if we assume that a certain accumulator has a capacity of forty-eight ampere-hours at the maximum discharge of eight hours, then we may use the battery normally at one charge as follows :

With one ampere for.....	48 hours
With two amperes for.....	24 hours
With four amperes for.....	12 hours
With eight amperes for.....	6 hours

The utmost precautions must be taken in caring for accumulators; this is of paramount importance, because they are very sensitive to shocks and over-exertion, and any bending of the plates is liable to give rise to short circuits. There is likewise danger of leakage of acid, breaking of glass cells, etc. Another point to be remembered is that the cells must be frequently charged and discharged; if this is neglected the plates will rapidly become impaired.

It must not be forgotten that the cells must be arranged in a "series."

Sulphuric acid of the best quality must always be used in diluted form and free from all impurities. The strong acid should be diluted with absolutely pure water to a specific gravity of 1200 or 25 Beaumé as shown by the hydrometer at a temperature of 60° F. In mixing the electrolyte the acid must always be poured into the water. The electrolyte should never be added to the cells until cold.

In subsequent charges and in general use, it is only necessary to charge until the voltage is 2.5 per cell while charging. It is advisable to charge the cells once a week until the voltage per cell is 2.5 volts or about one-third the normal charging rate.

When discharging, the electro-motive force of each cell, as measured by the voltmeter, must not be allowed to sink below 1.85 volts; thus, in the case of a 6-cell battery 11 volts is the lowest limit for the discharge.

Cells should never be permitted to stand idle if more than 75 per cent. of their capacity has been used.

If a battery is to remain idle for a long time, it should first be fully charged and then given a recharge enough to bring it to a boil, and left charged.

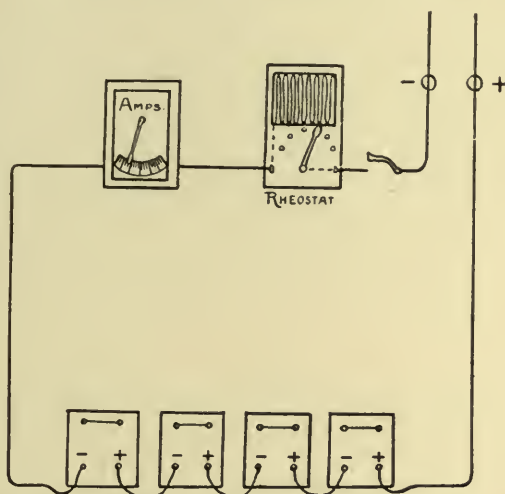

Fig. 6.—Diagrammatic view, illustrating the charging of a battery by the ammeter and volt-meter.

Always see that the cells are well covered with the electrolyte. If the latter has been spilt or become partly evaporated, it must be replaced with distilled water, and during the charging the top should be open so as to allow the escape of the hydrogen bubbles. Avoid unnecessary vibration and shaking of the cells. With proper care the accumulator should render good service for five to eight years.

Accumulators may be *charged* in any of the following five ways :

1. Primary cell.
2. 110-volt (direct) current.
3. Alternating current.
4. Bicycle dynamo.
5. Thermopile.

(1) The method by the primary cell is not practical, because the labor involved is unpleasant and tedious, and the process is a most lengthy one.

(2) The second method, or the use of the 110-volt (direct) current, is the most practical and most easily available method in use. It is necessary in this method to find the correct polarity of both the 110-volt and also of the accumulator. The manner of determining the polarity will be discussed in a subsequent chapter. It is necessary by this method to offer a resistance to the current, owing to the circumstance that the degree of voltage is too great for the accumulator. The means employed to effect resistance to this excess of current are either a group of lamps or the rheostat. In the latter method the ammeter is placed in the path of the current, and the rheostat is so regulated that the exact voltage sent to the accumulator can be determined by the amperage recorded by the ammeter. (Fig. 6.)

The simpler and cheaper method is that obtained by the group of lamps, mounted on a base and connected in parallel. Each lamp (16 candle-power) is equivalent to one-half an ampere; therefore, by this method we can accurately estimate the resistance required, by introducing that number of lamps which will be necessary to produce the proper amperage for charging the accumulator. When the accumulator is not properly connected, the lamps burn more brightly than usual. (Fig. 7.)

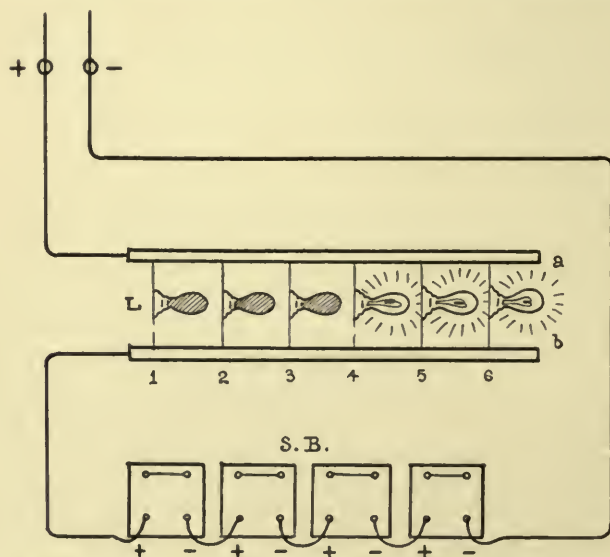

FIG. 7.—Diagrammatic view, illustrating the charging of a battery by a bank of lamps.

(3) The alternating current presents the disadvantage that, not being unidirectional in character, it requires the employment of a "converter" in order to produce a unidirectional current, and also to provide a low voltage that may be suitable for charging an accumulator.

(4) Where it is impossible to obtain a current, as on the battle-field, ingenious use has been made of the bicycle, by employing it as a motor and attaching it to a dynamo, which generates the current for charging the accumulator. This clever thought originated with Major Battersby in his memorable Soudan campaign, and the method has been successfully imitated in South Africa. Other means, but not so practical, are by water-power, windmill, or by horse- or man-power.

(5) The fifth and last method is by the use of the thermopile for charging purposes, which has found but little favor, and is rarely, if ever, employed in this country.

C. DYNAMIC OR ELECTRIC MAINS are of two kinds :

(a) *Direct.*

(b) *Alternating.*

(a) **Continuous or Direct.**—In places where a current from the continuous commercial main is available and voltage ranges from 100 to 250, advantage is often taken of this source of energy, owing to the fact that it presents few difficulties and demands but little attention ; the rheostat alone being necessary to regulate both the voltage and amperage.

(b) **Alternating or Street Current.**—When it is necessary to employ an alternating current, there will be required a motor-transformer.

D. THERMOPILES.

In 1822 Professor Seebeck, of Berlin, accidentally discovered that when heat is applied to a circuit-junction, a current of electricity is produced ; also, that when two junctions are of different temperatures, the current produced is directed from the warmer to the colder junction. Thermopiles are very seldom employed for working an induction coil. Their use is extremely limited in this country.



## CHAPTER II

### THE STATIC, FRANKLINIC, OR FRICTIONAL CURRENTS.

THERE are three chief forms of electricity used in medicine and surgery :

Static, Franklinic, or frictional.

Galvanic, continuous, or direct.

Faradic, interrupted, or indirect.

The other so-called varieties, such as the sinusoidal current, high-frequency currents, etc., are modifications of the above forms.

#### I. The Static or Influence Machines.

Ever since static electricity was discovered and the first static machine was invented by Otto von Guericke, a burgomaster of Magdeburg, Germany, in 1647, the subject has received the closest study from scientific minds. Sir Isaac Newton eagerly seized and improved upon von Guericke's discoveries, and these early researches were continued through the centuries by English, German, French, and Italian philosophers, not the least conspicuous among whom may be cited Ramsden, Planté, and De la Fond. While the friction or static machines of these searching inquirers are now obsolete, their persistent study laid the foundation for the present-day *influence* machines.

In the construction of influence machines two important principles are carried out : (1) the principle of *influence*, whereby a conductor touched acquires a charge of the opposite kind, and (2) the principle of *reciprocal accumulation*.

"In Fig. 8 let us, for instance, employ two insulated conductors, A and B, electrified ever so little, one positively and the other negatively. Let a third insulated conductor C, which we shall call a *carrier*, be arranged to move so that it first approaches A and then B, etc.

"If touched while under the influence of the small, positive charge on A, it will acquire a small negative charge ; suppose that it then moves on, and gives this negative charge to B, and it then be touched while under the influence of B, so acquiring a small positive charge. When it returns toward A, let it give up this positive charge to A, thereby increasing its positive charge. Then A will act more powerfully, and on repeating the former operations both B and A will become more highly charged. Each accumulates the charges derived by the influence from the other. This is the fundamental action of all the modern



influence machines, dating from 1860, the first having been constructed by C. F. Varley, consisting of six carriers mounted on a rotating disk of glass.<sup>1</sup>

A. TYPES OF INFLUENCE MACHINES.

(a) The *Wimshurst* influence machine (Fig. 10) consists of two circular disks of glass, so mounted as to be rotated in opposite directions, at a distance of one-eighth of an inch apart. Each disk is attached to the end of a boss of ebonite, upon which is turned a small pulley. Both disks are well varnished and cemented. To the outer surface of each are twelve or more sectors, made of thin brass and at equal angular distances apart. Twice in each revolution, the two sectors situated on the same

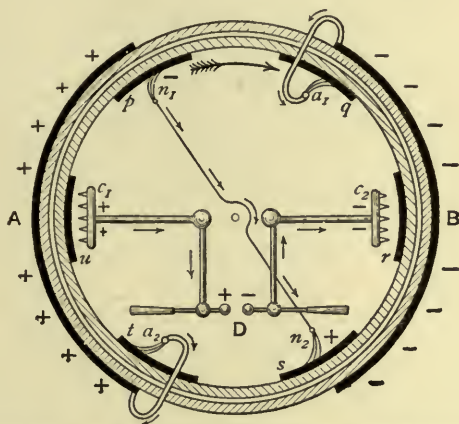

FIG. 8.—Diagrammatically illustrates the principle of influence and accumulation of static or influence machines.

diameter of each disk are momentarily placed in metallic connection with one another by a pair of fine wire brushes, supported at the middle of its length, by one of the projecting ends of the fixed spindle upon which the disks rotate, the sector plates just grazing the tips of the brushes as they rotate. The position of the two pairs of brushes with respect to the fixed collecting combs and to one another is variable.

The fixed conductors consist of two forks, furnished with collecting combs directed toward one another and toward the two disks which rotate between them, the position of the two forks, which are supported on ebonite pillars, being along the horizontal diameter of the disk. To these fixed conductors are attached the terminal electrodes, whose distance apart can be varied. This form of machine is very efficient and self-exciting, provided that a sufficient number of sectors be present, for it is

<sup>1</sup>Sylvanus Thompson, *Elementary Lessons in Electricity and Magnetism*, pp. 56, 57.

found that the machine works at full power after the second or third revolution of the handle. The Wimshurst machine works best when the resistance of the discharging circuit is high, and it has been proposed to enclose the apparatus in a strong metal case, and to work it under a pressure of several atmospheres, thus avoiding leakage through brushing.

The *theory of action* of these machines is perhaps best explained by the aid of the accompanying illustration (Fig. 9), in which, for the sake of greater clearness, "two rotating plates are represented as though they were two cylinders of glass, rotating in opposite directions, one within the other. The smaller inside cylinder, in the figure, represents the front plate, and the larger outer, the back plate: the front plate rotates right-handedly, and the back plate left-handedly. The neutralizing brushes,

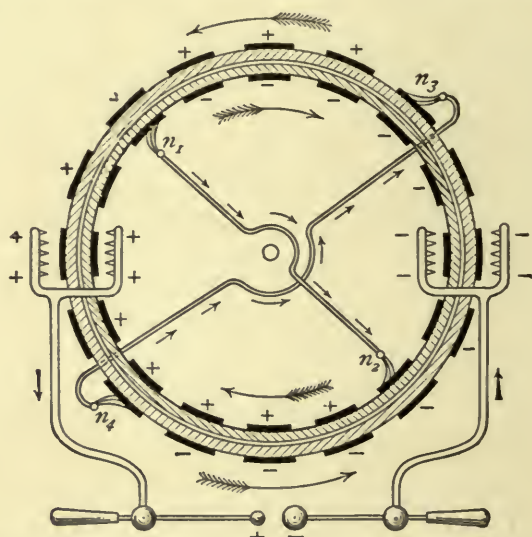

FIG. 9.—Illustrates diagrammatically the theory of action of a Wimshurst influence machine.

$n_1$ ,  $n_2$ , touch the front metallic sectors, represented near the top of the diagram, to receive a slight positive charge. As it is moved onward toward the left it will come opposite the place where one of the front sectors is moving past the brush  $n_1$ . The result will be that the sector touched while under influence by  $n_1$  will acquire a slight negative charge, which it will carry onward toward the right. When this negatively charged front sector arrives at a point opposite  $n_3$ , it acts inductively on the back sector which is being touched by  $n_3$ ; hence this back sector will in turn acquire a positive charge, which it will carry over to the left. In this way all the sectors become more and more highly charged; the front sectors carrying over negative charges from left to right, and the back sectors carrying over positive charges from right to left. At the lower

half of the diagram a similar but inverse set of operations take place. For when  $n_1$  touches a front sector under the influence of a positive back sector, a repelled charge will travel along the diagonal conductor to  $n_2$ , helping to charge positively the sector which it touches. The front sectors, as they pass from right to left, in the lower half, will carry positive charges; while the back sectors after touching  $n_4$  will carry negative charges from left to right.

“The metal sectors then act both as carriers and inductors. It is clear that there will be a continual carrying of positive charges to the

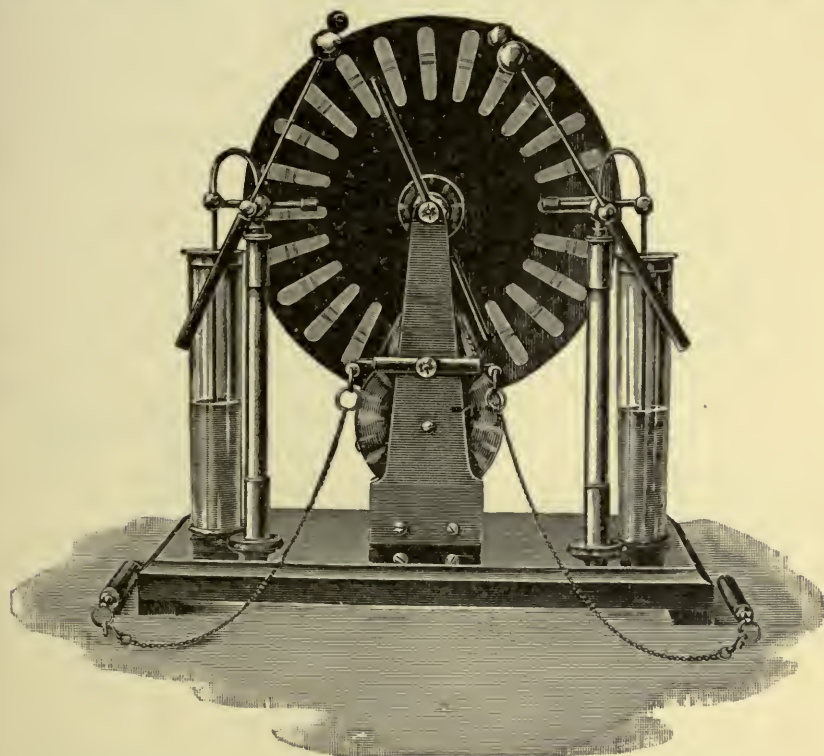

FIG. 10.—Wimshurst influence machine.

right, and of negative charges to the left. At these points, toward which the opposite kinds of charges travel, are placed the collecting combs communicating with the discharging knob.”<sup>1</sup>

(b) *Holtz* of Berlin invented a very powerful influence machine. (Fig. 11.) In brief, it consists of two glass plates, the diameter of one plate being slightly larger than the other. The plates, though in close relationship, do not touch. The fixed plate contains two “windows”

<sup>1</sup> Sylvanus Thompson, *Elementary Lessons in Electricity and Magnetism*, p. 63.



directly opposite one another. Two bits of paper (field plates) are glued to the stationary plate, one above the window on the left side, and one below the window on the right. From each of these pieces of paper a tongue protrudes through each aperture, almost, but not quite touching the revolving plate. The plate is rotated in a direction opposite to that in which the tongue projects. The prime conductor consists of two metallic combs, supported by brass rods with knobs, and mounted on glass supports. Two other brass knobs with ebonite handles and knobs form the discharging electrodes, through whose agency the spark length can be varied. A neutralizing rod to minimize the reversal of polarity

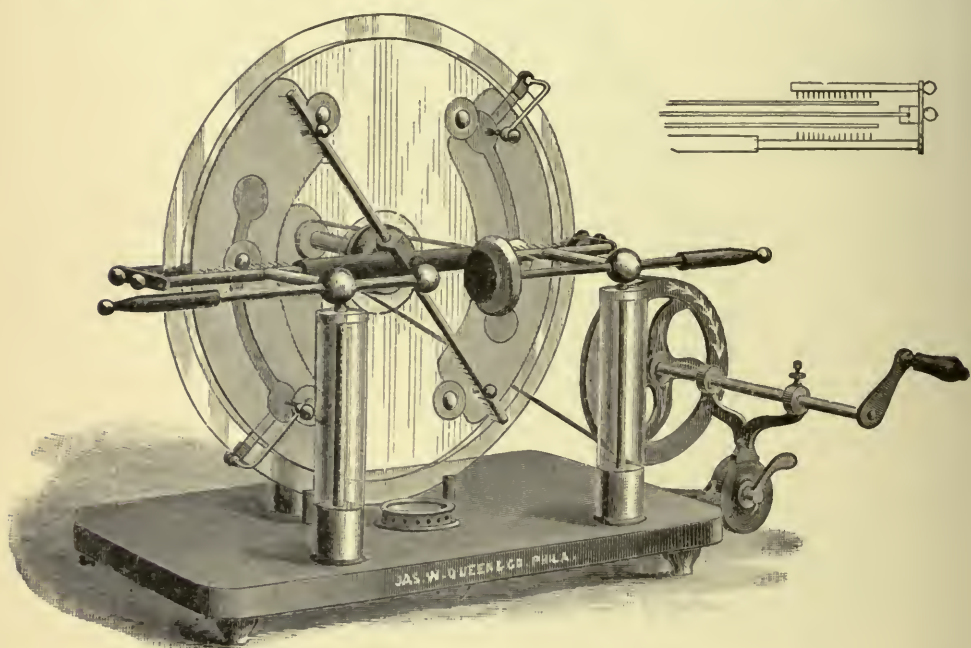

FIG. 11.—Toeppler-Holtz influence machine.

is also provided. Before working the machine, one of the field plates must be charged from an outside source and the knobs of the discharging rods must be brought together.

(c) The *Voss* or *Toeppler* is more self-exciting than the Holtz, but is less sure in its action than the Wimshurst. The *Voss* resembles the Holtz machine in many details, but the moving plates carry a few sectors, and these in their rotation touch a pair of brushes carried by two bent arms which connect with the field plates, and so convey charges from the moving plate to the armature of the fixed field plates. In this country there are practically no Wimshurst machines used. They are nearly all Toeppler-Holtz machines, that is to say, Holtz machines modified so as to



be self-exciting, as invented by Toepler. The Eastern manufacturers are largely using the Holtz machines which are excited by a smaller generator of the Wimshurst or Toepler type, while mostly all the Western manufacturers use the Toepler-Holtz type machine.

#### B. CARE AND MANIPULATION OF STATIC MACHINE.

In the use of influence machines certain requisites are necessary to insure satisfactory results. Chief among these are dryness and cleanliness. The accumulation of dust or moisture upon the insulating surfaces interferes with the high voltage that must be obtained. The machine may be freed from dust and moisture by the use of a dry silk fabric; the oxidation of the metallic sectors can be effectively obviated by cleansing them with a cloth previously immersed in benzine or gasoline. Alcohol should never be used on any varnished part, as it acts as a solvent thereof. During the summer months when the air is often surcharged with moisture, it becomes necessary to place in the case a deep tray containing fused calcium chloride; this must be free from impurity, else there will result oxidation of the metallic parts. Likewise during the torrid season it is found that the current acting on the air in the case of the machine, develops a nitrous oxide, and that the nitrogen combining with hydrogen forms nitrous acid accumulations, which are detrimental to the working of the machine. Wagner uses ventilators in his machine, which carry off the nitrous oxides, and recommends that during the summer months a dish containing oil, such as boiled linseed oil, be placed inside of the case. The oil takes up the active nitrogen because it has more affinity for the nitrogen than for the hydrogen. Sulphuric acid is also one of the best and most inexpensive driers that can be used in a static machine. When it is used, it should be placed in a broad, open dish, four or five inches deep, and the full-strength commercial sulphuric acid should not more than half fill the dish, as the acid will take up the moisture and increase until it has almost doubled its volume; then it loses its efficiency as a drier.

When used for exciting an X-ray tube, this machine must be operated by a power capable of giving a high and steady electro-motive force. In cities an electric motor (of the required horse-power) should be employed; in country places water motors or gasoline engines should furnish the power; hand power with this machine is inefficient for skiagraphy.

The length of a spark of a properly working machine ought to equal the radius of the revolving plates (approximately). Care should be exercised that the neutralizing brushes are so bent as to bring them in proper contact with the disks during the whole period of revolution.

The electro-motive force of a static machine depends upon the number of revolutions per minute, the size and number of the revolving plates, and the general construction and care of the same.

Glass plates have been in use for more than a century, but mica plates possess certain advantages. They are not fragile and less hygroscopic than glass ones, and I have never known them to warp. Because of the non-breakable character of mica, a high speed can be obtained for the generation of extremely high volume of tension of current.

Machines not self-exciting have a charge added. This is usually furnished by a revolving plate to which are fastened several brass sectors. On revolving, the latter are brought into contact with the brushes. The stationary plate of this machine encloses a sheet of tin-foil or paper as a collector.

A static machine in bad order is said to have "lost its charge" when it fails to generate electricity. This may be caused by dampness, by the humidity of the atmosphere, or by turning the crank attached to the driving-wheel in the wrong direction.

### C. ACCESSORIES.

#### THE LEYDEN JAR.

This is an electro-static condenser, so named from its invention by Cuneus, in the town of Leyden, in 1745. In its modern form, a Leyden jar is a cylindrical glass bottle, lined inside and out with tin foil, to within a short distance of the top. A brass knob inserted in the wooden cover is connected with the inner coating by means of a wire or chain.

Thus we have essentially two conductors, the one almost completely enclosed in the other and separated from it only by the thickness of the dielectric. If either conductor is put to earth, and the other insulated and charged, an opposite and nearly equal charge is induced in the former. Leyden jars are frequently connected in series (the cascade arrangement) to secure a potential difference equal to the sum of those due to the electrification of the individual jars, or in multiple, all outside coatings connected together and inner coatings the same, when increased quantity is desired.

#### ELECTRODES. (Figs. 12 and 13.)

These may be of metal or of wood. The metallic electrodes are usually of brass, made in a variety of shapes and sizes, and may be round, pointed, etc., each being mounted upon a holder of ebonite (vulcanite), which acts as an insulator. Rollers are usually made of brass, and mounted upon a base or stem of ebonite. The wooden electrodes are usually described as discharge electrodes, but they are not so frequently

employed as are the metallic variety. Lately glass vacuum electrodes have come into vogue. A convenient handle for holding electrodes is shown in Fig. 14.

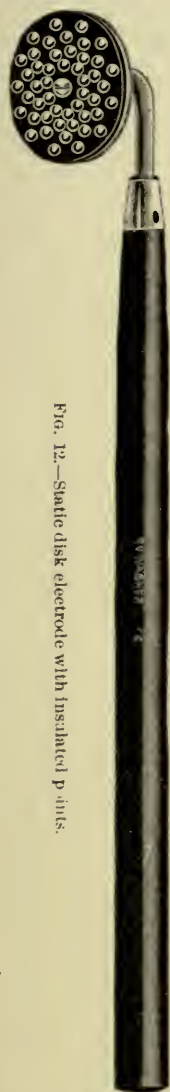

Fig. 12.—Static disk electrode with insulated p. ints.

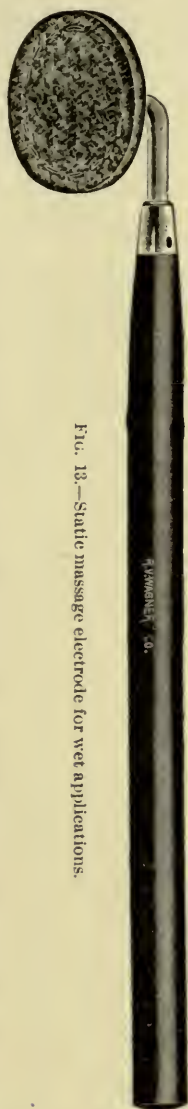

Fig. 13.—Static massage electrode for wet applications.



Fig. 14.—Universal hair-rubber handle for holding electrodes.

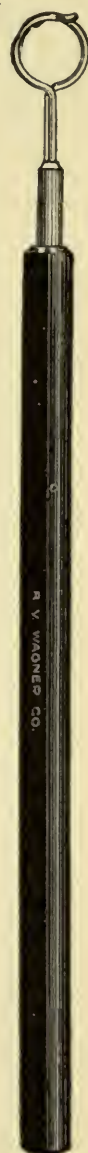

Fig. 15.—Insulated hook for holding conducting cord.

CHAIN-HOLDER.

This is usually a brass ring or hook attached to an ebonite stem, and is employed for holding the chain which conducts the current from one



pole of the machine to the electrode (Fig. 15). It prevents bringing the chain in contact with the patient, and thus avoids shock.

#### MUFFLER.

This is a cylindrical glass tube, into the ends of which are fastened discharge rods. The tube in a horizontal position is held to the discharge rods of the static machine by means of wire hooks. The rods of the muffler can be readily adjusted by simply turning them in a screw-like fashion. This is employed for the purpose of lessening the noise from the discharge rods of the static machine.

#### PREPARATION OF THE PATIENT.

When a patient comes for treatment it is necessary to ascertain the nature of the disease, before deciding upon the kind of treatment to be instituted. If the method selected requires the removal of some of the apparel, this should be arranged by the physician's attendant or nurse in a separate room. If much of the clothing is removed, a wrapper or loose gown should be thrown over the patient. If the patient is nervous it is advisable to instruct the attendant to remove as few of the garments as practicable, so as not to offend modesty and in order to lessen the fear so frequently induced by the careless therapist. Celluloid combs and all hair-pins should be removed from the patient's head; if hair-pins be permitted to remain they may cause unpleasant pricking sensations in the scalp.

The patient should be placed in a comfortable position and far enough from the machine to prevent shocks from the emitted sparks. In damp weather or when the current is not very strong the patient should hold the metallic electrode. The cords leading from the discharge rods should not touch the ground, the patient, or each other: if they rest upon the floor or "ground" there will be a flow of current into the earth, if they touch the patient, shock will occur, and if they touch one another a short circuit will result. I prefer to treat the patient in the sitting posture, as this permits the application of the current to all parts of the body, especially if he be seated upon a revolving stool. Occasionally it may be necessary to adjust his chair so that he cannot rotate it, thus allowing a constant flow of current to the part needing treatment.

#### POLARITY.

The polarity of a static current is not of great moment. I have heard some patients say that the current of the positive electrode is more pleasant than the negative and others affirm the opposite. I am of the opinion that there is little, if any, difference between the positive and



negative electrodes, so far as the emanating current is concerned. Nevertheless, this is easily determined by starting the machine with the rods slightly apart, and observing that the spark is whitest near the positive pole, due to incandescent oxygen being whiter than incandescent nitrogen.

The positive electrode emits a sharp hissing noise when placed in a horizontal position.

No current will flow when a non-conductor is applied to the negative discharge, but it will flow from the positive.

The positive pole can be determined by the collecting combs showing points of light, while a brush-like form is evidenced upon the negative side. This is best observed in a darkened room while the sliding rods are in contact.

If we separate the balls on the ends of the sliding rods for an interval of two centimeters, the spark stream issuing between the rods displays a distinct violet portion, which begins at the ball in a bright point. This violet portion denotes the negative pole, while the positive pole is recognized by a bright area of white light lying near it.

To reverse the polarity of an influence machine, the usual procedure is to ground both terminals, and give the machine a few turns in the opposite direction, then remove the grounds and start the machine normally. The effect of this operation is rather uncertain, and Herr J. R. Jannszkiewicz<sup>1</sup> has devised a system which is more reliable. In this one pole of the machine is connected electrically to the inducing plate for the opposite pole. The machine is revolved in the normal direction, and if the connection then be broken the polarity of the machine will be found to be reversed. If the machine is running at a fair speed only a momentary connection is needed, but if it is running slowly it may be necessary to leave the connection for ten or fifteen seconds. Care should be taken that good electrical contact is made. A new pole changer that bids to become very popular is shown in Fig. 16, which illustrates the wrong connection of the Crookes tube with the static machine, as is indicated by the heavy lines. By this arrangement we correct the polarity without changing the position of the tube, by sliding the rod, H, from C to C', the rod carrying the positive pole, which becomes A' (anode). The negative pole, D, touches the metal D', which is carried, and becomes B' (cathode).

#### IDIOSYNCRASY.

By this term is meant the susceptibility of the patient to the action of the static electric current. It has frequently been observed that

<sup>1</sup>Physikalische Zeitschrift (Leipsic), abstracted in the Electrical Review, Oct. 15, 1904.

certain patients are unusually susceptible to static electricity. I have seen many cases where a static breeze applied to the head was sufficient to cause fainting, or at least dizziness. For such patients it is necessary to diminish the strength of the current, also to shorten the length and lessen the number of applications.

#### THE DOSAGE.

By this term is meant the length of time required for administering the current in the particular case, the intensity of each treatment,—*i. e.*, the strength of static current produced and applied,—and the frequency

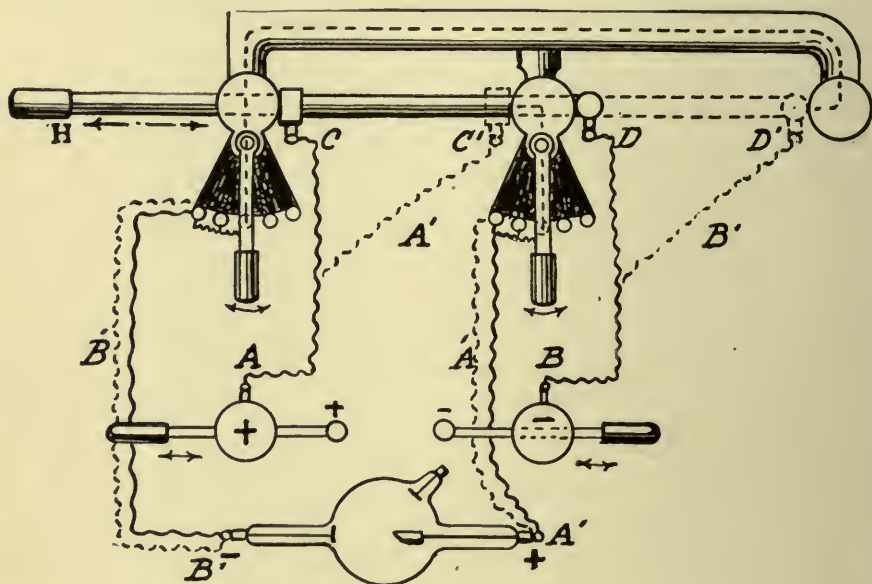

FIG. 16.—Pole changer of Betz.

of its use. The length of each application should be between ten and twenty-five minutes. The number of applications will naturally depend upon the character of the disease treated, the suffering of the patient, and also upon idiosyncrasy. Here is where good judgment and skill on the part of the therapist are required. It is the general practice to give from one to five treatments a week. Frequently the patient inquires as to the number of applications requisite before a change in the disease will be noted. Unfortunately, we are not able to answer such questions satisfactorily. I have seen cases where only three or five treatments were necessary; again I have seen cases of the same disease where twenty treatments were necessary before a change for the better could be observed.



FIG. 17.—Static breeze, concentrated brush discharge, or spray. If the crown is positive, it is a contractor of blood-vessels and acts as an anæsthetic. If it is negative, it dilates and liquefies and is an irritant. The indicator on the machine is turned to the printed word "breeze."



FIG. 18.—Static negative insulation or static bath. Patient holds the negative electrode on an insulated platform; positive is grounded and the sliding electrodes are widely separated.





FIG. 19.—Direct spark.



FIG. 20.—Indirect spark.

## II. Modes of Application.

The forms of application used in electro-therapy are :

CONVECTIVE	}	DISCHARGES.
DISRUPTIVE		
CONDUCTIVE		

A CONVECTIVE discharge occurs when electricity of a high potential discharges itself at a pointed conductor by accumulating there with a density sufficient to electrify the neighboring particles of air (these particles then flying off by repulsion), and conveying away with them part of the discharge. This form of application is illustrated in the use of the *static bath*, the *breeze*, and the *spray* as given off from metal electrodes, the high-frequency discharges from glass vacuum tubes, etc.

The DISRUPTIVE discharges embrace the various sparks,—the *long*, *short*, and *friction*.

The CONDUCTIVE discharge is derived from an electrified conductor. This may be a continuous current flowing through a thin wire connecting the knobs of an influence machine or joining the positive pole of a battery to the negative pole.

### A. CONVECTIVE CURRENTS.

In using the *brush discharge* (Fig. 17) the patient holds either electrode while the other, which may be pointed, broom-shaped, or coronal in outline, is applied to the area to be treated. This includes the *breeze* and *spray* (all these terms being synonymous); the *breeze* is the concentrated brush discharge.

The *static bath* (Fig. 18), also called static insulation, is administered by having the patient on an insulated platform in communication with one of the poles of the machine; after some turns of the handle, it is found that he is charged with positive electricity of a high potential, while there is a constant waste of electricity from all parts of his body and clothing. The effect of the static bath is ultimately sedative and it is the form usually employed. It may be greatly intensified by applying to the affected part a tinsel rosette instead of a crown piece. Strong revulsive effects, leading to actual blistering, may occur when the patient is connected directly with the positive pole. Dr. G. Betton Massey, who has had a great deal of experience in electro-therapeutics, believes that this intensified spray has a deep penetrating action and is of great value in intractable chronic rheumatism.

In the *interrupted insulation* the negative electrode is held by the patient and the positive is grounded. The sliding electrodes are moved to and fro, so as to produce an interruption in the current.

## B. DISRUPTIVE CURRENTS.

These are subdivided into the direct, indirect, and friction.

In the *direct disruptive current* (Fig. 19) the patient is seated on the platform, holding either the positive or the negative electrode, the remaining electrode being applied to the affected part. The Leyden jar may or may not be in the connection. When it is so connected, the current, as a rule, is usually too severe. The spark-gap is wide open.

Direct sparks are very painful, and are to be used only in cases of surface anæsthesia.

The *indirect disruptive current* differs from the above in that the patient sits on the platform, holding the negative electrode, the positive being grounded. If the electrode chain is attached to the water-pipe (the indifferent pole being attached to the gas-pipe), more capacity is gained, the single sparks give good muscle responses with little pain. (Fig. 20.)

The *friction disruptive current* differs from the indirect only in that the roller electrode is rapidly applied against the affected part. (Fig. 21.)

## C. CONDUCTIVE CURRENTS.

Conductive currents are subdivided into the static induced current and the wave current.

The *static induced current* (Fig. 22) is in connection with both the Leyden jars and the patient; the electrodes must be of metal and applied to the bare skin or mucous membrane. The spark-gap is closed at first, and then gradually opened to the point of toleration.

In the *wave current* the positive electrode is grasped by the patient and the negative is applied to the ground; the necessary electrode is block-tin or metallic cloth placed on the bare skin or mucous membrane. Begin the application with the discharge rods touching; then gradually separate them until the desired strength of charge is attained.

The electric *souffle* or *wind* is applied by directing the point of a metallic uninsulated rod toward, but one foot away from the patient. The point is electrified negatively,—*i. e.*, if we are using positive electricity. The surrounding air particles, becoming electrified, are attracted to the nearest part of the patient's body, the stream of molecules producing a perceptible current of air. The action of the *souffle* is sedative.

Dr. William J. Morton's "Wave Current and High-Frequency Apparatus"<sup>1</sup> is described as follows:

"One prime conductor of the static generator is grounded; the other is connected with an electrode applied to the patient who is on an

<sup>1</sup> Bulletin Officiel de la Société Française d'Électrothérapie, Jan., 1899; Electrical Engineer, vol. xxvii., March 2, 1899.





FIG. 21.—Friction spark treatment.



FIG. 22.—Static induced current. In this form of static treatment the indicator is turned to the word "induced," which connects the Leyden jars. The cords are attached to the binding posts, and the sliding electrodes are very gradually separated, as otherwise the shock would be too intense.

insulating stand. The current received by the patient is due to the spark discharge between the knobs of the prime conductors. The patient forms one coating of a Leyden jar condenser, the other coating of which is the earth and surrounding objects and walls connected electrically therewith.

“The greater part of the charge and resulting strain on the dielectric (air) will be found at those parts of the patient and the floor or walls of the room that are nearest together.

“If the spark-gap be long, the time of charging by the small continuous current will also be comparatively long, because the potential must be raised to a high point in order to produce a long spark. The duration of the discharge, which will probably be an oscillatory one of relatively high frequency because of the small capacity of the condenser, will be short. The small continuous charging current will flow through the patient without causing appreciable sensation. The sudden oscillatory discharge may flow over the surface of the patient because of its high frequency, and therefore without disagreeable effect. As the length of the spark gap is diminished, the time and amount of charge become less, with a resulting diminution of sensation.”

The following chart illustrates static modalities in a convenient form :

CLASS.	NAME.	CONNECTIONS FOR POLES AND ELECTRODES.	LEYDEN JARS.	Insulation of Patient	REQUISITE ELECTRODES.	SPARK - GAP.
Conductive.	Static induced.	Both to Leyden jars, and both to patient.	Yes	No	Metal, to bare skin or to mucous membrane.	Closed to begin and gradually open to tolerance of patient.
	The wave current.	Positive to patient. Negative to ground.	No	Yes	Block tin or metallic cloth to bare skin or mucous membrane.	As in static induced.
Disruptive.	Sparks: Indirect and friction.	Positive to patient or to platform. Negative to ground. Electrode to ground.	Optional, but as a rule too severe.	Yes	Brass balls.	Wide open.
Disrupto-convective.	Brush discharge.	Positive to ground. Negative to patient or to platform. Electrode to ground.	No	Yes	Made of wood of various sizes and shapes.	Wide open.
Con- vective.	Breeze and spray	Positive to patient or platform. Negative to ground. Electrode to ground.	No	Yes	Usually brass point, single or multiple, crown or broom.	Wide open.
	High - frequency.	Positive to ground. Negative to electrode.	No	No	Special glass vacuum.	Begin $\frac{1}{2}$ " — gradually regulate to capacity of patient.
	High - frequency specially interrupted.	Both to series interrupter and negative current to electrode. Positive to ground.	Yes	No	As ordinary h. f.	Wide open.
	Potential alternation.	Positive to patient. Negative to ground.	No	Yes	Water, block tin, wooden or brass, depending upon work required.	Wide open (see remarks).
	The static bath or general electrification.	Usually positive to patient or platform. Negative to ground.  NOTE. — These are the usual connections. It sometimes happens that the reverse may suit certain cases. This does not apply to the high - frequency currents, where the connections cannot be changed.	No	Yes	None.	Wide open.



# MODALITIES

F. HOWARD HUMPHRIS, M.D., F.R.C.P.

PHYSIOLOGY AND THERAPEUTICS—(after SNOW).	SPECIAL INDICATIONS.	REMARKS.
<b>SUBJECTIVE.</b> a. Induces muscular contraction. b. Physiological tetanus. c. Local vibratory effect. <b>CLINICAL.</b> a. Relieves local pain. b. Relieves local congestion. c. Increases secretion.	Obstinate constipation. Painful neuroses.	The constitutional effects of this current are practically <i>nil</i> .
<b>SUBJECTIVE.</b> a. Local vibratory effect. b. Induces muscular contraction. c. Physiological tetanus: <b>CLINICAL.</b> a. Diminishes local swelling and congestion. b. Local pain relieved. c. Acute muscular spasm relieved. d. Increase of local metabolism.	Insomnia, facial neuralgia, gout, sprains, asthma, rheumatism, pelvic congestion, lumbago, dysmenorrhœa, impotency, prostatitis, dyspepsia (nervous), gleet, constipation, goitre.	During the application of this current to extra-sensitive areas, e.g. forehead, eye, ear, nose, and throat, it is advisable to do away with the negative grounding. The two forms of the intensification of this current have been omitted; they are more local and less constitutional in their effect when this (the unmodified) cannot be used, then the static induced current is indicated.
<b>SUBJECTIVE.</b> a. Stinging sensation. b. Muscular contraction. c. Blanching, followed by redness, wheals, and even blisters, by successive applications. d. Increase of local secretion. <b>CLINICAL.</b> a. Relaxation of muscular spasm. b. Relief of pain. c. Hyperæmia and swelling lessened.	Muscular, subacute and chronic rheumatism, locomotor ataxia, rheumatoid arthritis, all deep-seated nervous structural lesions, and deep-seated pain, sciatica. Of all local currents the spark is the best diaphoretic.	There is also the direct spark; it is very severe and only of use in humid weather. In other respects it resembles the ordinary spark, but the positive connection is to the patient and the negative to the electrode. The currents in order of preference for the relief of pain: 1. Wave. 5. Breeze. 2. Brush. 6. Spray. 3. High-frequency. 7. Static bath. 4. Sparks. 8. Static induced.
<b>SUBJECTIVE.</b> a. Increases local secretion. b. Rubefacient, if pushed. c. Local antiseptis. <b>CLINICAL.</b> a. Relieves local congestion. b. Lessens local swelling. c. Diminishes local pain. d. Promotes local metabolism. e. Destroys superficial septic processes.	Early acute rheumatism, sprains, abscess, swelling in fractures, early stages in any acute inflammation, lumbago, gout, otitis media, lupus, tubercle, and any congestion or stasis, with or without germ life.	
The same as the brush discharge, but more irritating and less effective.		The positive breeze is stimulating, the negative is sedative. . . . The negative breeze is where the negative pole and the electrode are both grounded and the positive pole is connected with the patient.
	Increase voice range. Piles, rectal ulcer, fissure. Tonsillitis, catarrh, hay fever. Lupus, acne, and other skin affections.	Ozone evolved . . . Vacuum electrodes <i>without</i> wire are preferable, because they are less liable to puncture, cheaper, and equally efficient.
	The same as for the ordinary high-frequency current.	Even more ozone is evolved. Note that the positive current comes from that Leyden jar attached to the negative prime conductor, and vice versa.
	Painless, simple, and fairly effective. The indications are the same as for the spark.	Note that the interruption is effected with the stand ball electrode and the prime conductor to which the patient is connected.
<b>ALL STATIC MODALITIES:</b>		
<i>Circulatory System.</i>		
a. Lessen arterial tension. b. Lessen heart frequency. c. Lengthen diastole. d. Increase pulse volume.		
<i>Respiratory System.</i>		
a. Rapid and labored breathing relieved. b. Deepened breathing, with increase in elimination of CO <sub>2</sub> .		
<i>Nervous System.</i>		
a. Relieve irritability. b. Induce soporific effect.		
<i>Vaso-motor System.</i>		
a. Induce diaphoresis. b. Induce diuresis, with increased elimination of urea. Increase general metabolism.		
Where a general sedative is indicated. Congestive headache. As a prelude to, or in conjunction with, other static modalities.		

## CHAPTER III.

### GALVANIC, CONTINUOUS, OR DIRECT CURRENT.

**GALVANISM** is named in honor of Galvani, a physician of Bologna, who in 1790 observed that convulsive seizures could be produced in the limbs of a dead frog, when certain metals were made to touch the nerve and muscle simultaneously. The electrical theory of these motions, however, originated with Volta, and, deserving of the credit that his genius gave to science, his name is inseparably linked with the subject of galvanism.

#### BATTERY.

A galvanic battery is a collection of two or more galvanic cells (Fig. 23) so connected that the electricity generated by all can be conducted

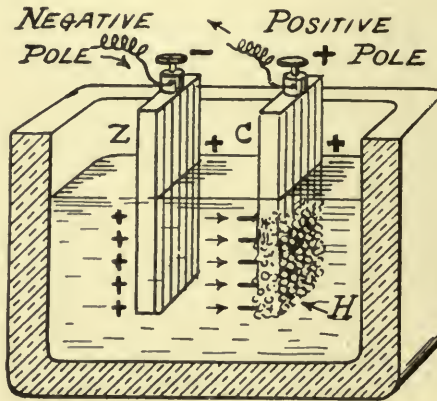

FIG. 23.—Galvanic cell.

through a single wire. A cell consists of two dissimilar metals, one of which is more readily acted upon by the electrolyte than the other. The metals usually selected are zinc and copper. Such a cell is frequently referred to as a galvanic couple.

#### CONNECTIONS.

Upon joining the two metals with a wire an electrical circuit is formed. If a number of such simple cells are united in "series," the zinc plate of one joined to the copper plate of the next, and so on, a greater difference of potential will be produced between the copper "pole" at one end of the series and the zinc "pole" at the other.

Hence, when two or more poles are connected by a wire, there will be a greater flow of electricity than would be generated by a single cell. Such is the principle of the galvanic battery. The connection of zinc to copper throughout the cells makes the latter in "series." By this arrangement the amperage is the same as for a single cell, but there is a great increase of voltage.

The cells are said to be in "parallel" when all the zines are connected with each other and all the coppers are united to each other. In this instance the electro-motive force is not increased, but the strength of the current is materially augmented.

#### TYPES OF CELLS.

The cells used in the formation of batteries may be either "dry" or "wet." By a "dry" cell is meant the combination of certain metallic bodies in such a way as to produce a simple galvanic current without making use of an electrolyte; the latter, however, is employed in the "wet" cell. Of these the best is the zinc-carbon type, of which there are a variety on the market.

*Grove's Cell.*—This consists of an outer cell of glazed ware containing an amalgamated zinc plate and dilute sulphuric acid. In the inner porous cell, a strip of platinum serves as a negative pole and dips into the strongest nitric acid. The hydrogen generated by the sulphuric acid acts upon the zinc and transferred to the platinum element meets the nitric acid and decomposes it. The platinum is not acted upon by the acid. The advantage of the Grove cell is its lowest internal resistance, and its high electro-motive force.

Lately the use of *dry cells* has come into vogue. These are portable, do not need attention as to refilling, etc., and they are in every way equal to the best of the wet batteries. Most of them are made of chloride of silver, and are encased in a readily portable box.

The *Bunsen cell* (Fig. 24) differs from the Grove's cell only in that it contains a carbon cylinder in place of a platinum plate. A common Bunsen cell will give a current strength on short circuit of 12 amperes.

To avoid the annoyance and the danger occasioned by the liberation of nitrous acid fumes derived from the nitric acid employed, chromic acid or a combination of potassium bichromate and sulphuric acid may be substituted. This constitutes the *bichromate cell*. This cell is capable of generating a high electro-motive force.

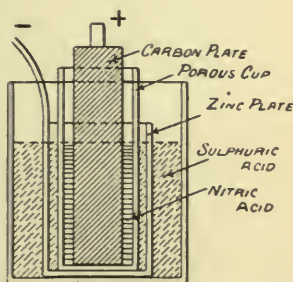

FIG. 24.—Bunsen cell (double fluid).



The *Leclanché cell* consists of a porous cup and a carbon plate. The positive element consists of a rod of zinc, having a copper wire attached. The exciting fluid is a solution of sal ammoniac, in which the zinc dissolves, forming a double chloride of zinc and ammonia; while ammonia gas and hydrogen are liberated at the carbon pole.

#### CARE OF THE BATTERY.

When a battery is frequently and continuously used, it is essential that the plates should be kept clean by washing, scraping, etc. The solution must be renewed from time to time, and the zines must also be amalgamated.

When not in use, the metal plates should be withdrawn from the solution. If they remain too long a time, a deposit of salt occurs on the top of the zines, which must be removed to insure the correct working of the apparatus. The battery is working correctly when bubbles of hydrogen are perceived to rise at the sides of the zinc.

#### CHARGING THE CELLS.

Dissolve one and one-half ounces of bichromate of potash in ten ounces of cold water, and add one ounce of sulphuric acid. Allow the solution to cool.

#### POLARITY.

When a battery has been disconnected and put together again, especially if it has many complex parts, there is danger that the positive pole may be accidentally connected to the binding screw marked "negative," and *vice versá*. To obviate this error it is necessary to resort to some method of testing the polarity of the electrodes. For this purpose the use of wet litmus answers admirably. The ends of the wires resting on the litmus for a few minutes will show the results of electrolysis, the paper becoming reddened by the acid liberated at the positive pole, and will turn blue at the cathode or negative pole. Other reagents proposed include a solution of phenol-phthalein in dilute alcohol, which gives a purple-red color at the cathode.

A quickly performed test, is to immerse the tips of the wires in a saline solution, and it will be found that the negative pole will give off double the volume of hydrogen gas in comparison with the oxygen gas liberated at the anode.

#### WALL CABINET. (Fig. 25.)

This is of great utility, in that it allows of a wide range and variation of current. It is so constructed as to be readily adapted for use with



the 110-volt current, with any commercial current, or with a series of cells. It combines a galvanic, faradic, and sinusoidal outfit.

Direct commercial currents are often used instead of cells, but when a commercial current is used the means of regulating the voltage is of

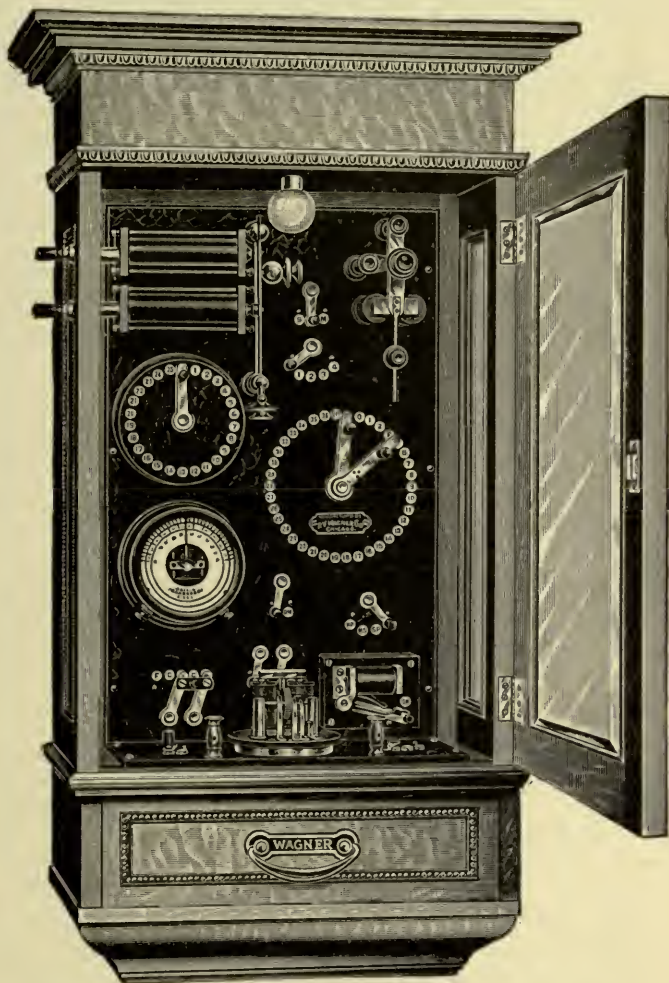

FIG. 25.—Wall cabinet for galvanic, faradic, and sinusoidal currents.

the utmost importance, because when the current passes through the tissues at low pressure or voltage, there is more diffusion, and the action of the current is more completely confined to the surface of the electrodes, and is thus less painful; whereas, when the current passes through the tissues at high pressure (as is the case when a rheostat

is used for regulating the strength), it does not spread out in passing through the tissues, and is thus more painful, but better adapted for cataphoresis.

#### THE RHEOSTAT.

The rheostat or current controller is an appliance for the reduction of the known electro-motive force. By its use we may also turn "on" or "off" the current-supply as gradually as desired. The various forms of rheostats have been fully described.

#### ELECTRODES.

These are of various forms and sizes, as the special part and purpose may demand. Some of the most useful electrodes are those that are adjustable. The latter are used in central galvanization, galvanization of the cervical sympathetic, etc. The adjustable electrode can be readily passed under the clothing, thus obviating the necessity of the patient undressing. Electrodes are made of various substances, sponge or absorbent cotton being most commonly employed.

The part to which the electrodes are to be applied must be free of all clothing. If the skin is harsh, dry, or hairy, it is well to moisten it with a sponge dipped in an aqueous solution of bicarbonate of soda. In beginning treatment, the strength of the current used should be regulated by the sensations experienced by the patient. A safe rule is to begin with a weak current and gradually increase it. It is necessary that the sponge attached to the electrode be frequently washed in warm water, and those that are much in use should be subjected to the disinfecting action of chlorinated solutions.

#### GALVANOMETER.

This is an instrument employed for the purpose of indicating and measuring the strength and the direction of a current. The principle involved in its construction is that a current of electricity will deflect a magnet from its normal position. An ingenious device is the Deprez-D'Arsonval galvanometer. This electrode bears a milliamperemeter and allows of application in any position. (Fig. 26.)

#### MILLIAMPEREMETER.

This instrument is the standard for measurement of electrical units. Under the principles of electricity we observed that the ampere was the unit of current strength, but this is entirely too powerful for electro-therapeutic purposes. The resistance of the human body is approximately 3000 ohms, and the milliampere (the one-thousandth part of an ampere) has been found a more convenient unit for that resistance.

## THE GALVANO-FARADIC BOX.

This is a combination of the galvanic and faradic battery. The current from the battery is generated by the Leclanché cell, which contains dry sal ammoniac, the necessary water being added when called into use. It possesses a great variety of combinations of length of wire, enabling the operator to regulate the current strength at will. The apparatus is provided with a rheostat, a rapid interrupter, a pole changer, a slow automatic interrupter, etc.

## DEFINITIONS OF TERMS.

Although many of these terms have been and will be defined at length, it is thought best to tabulate them here, so as to present in a compact form the commoner expressions employed in electro-therapeutics.

In *stabile* applications both electrodes are kept in a fixed position.

In *labile* applications one of the electrodes is moved over the surface, sometimes both are moved simultaneously.

A current is sometimes called *continuous* when it is allowed to flow in one direction, without interruption.

A current is said to be *interrupted* when it is broken by the removal of one of the electrodes, or by some form of current-breaker in the electrode, or by any method of breaking in the circuit.

*Voltaic alternatives* is the term applied to those applications in which the current is reversed continually, while the electrodes are kept firm.

The *ascending current* is one where the flow is from the periphery toward the nerve centre.

In the *descending current* the flow is in the direction from the nerve centre toward the periphery of a part.

By the term *dosage* we mean the amperage of the current employed either in treatment or for diagnostic purposes; the duration of each application of the electrodes, the amount of pressure exerted, and the size of the surface of the electrode applied, are conditions which must be taken into consideration when the dosage is to be accurately ascertained. (Modified after Rockwell.)

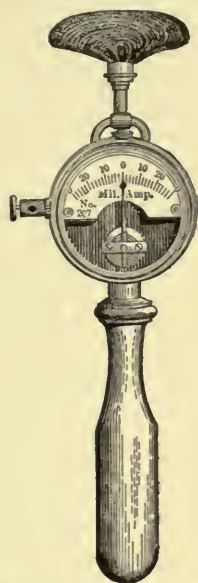

FIG. 26.—Deprez-D'Arsonval galvanometer. (Milliamperemeter.)



## METHODS OF APPLICATION.

There are two methods of applying current to a part,—(1) *stabile* and (2) *labile*.

(1) By the *stabile* method we mean the keeping of the electrodes on spots first ascertained, without moving them about in any direction,—*i. e.*, the electrodes are retained in stationary positions. After ascertaining the polarity, the sponges are carefully moistened, and it is then decided which pole is to be applied. After this has been done the electrode is gently applied to the part, bearing upon it with a slight degree of pressure. The current is now turned on, beginning with a minimum degree of current, and gradually increasing it by turning the lever of the rheostat; the amount of current applied depending upon the susceptibility of the patient. The current should not be turned off suddenly, as this is liable to shock and induce fear in the mind of the patient.

The sudden reversal of the polarity in the circuit formed, is also liable to produce an unpleasant sensation. Each and every apparatus has certain appliances and methods of working them, and the directions accompanying the instrument, as outlined by the manufacturer, should be carefully followed.

(2) *Labile*.—This method consists in keeping one of the electrodes at a certain indifferent part, while the other electrode is slowly moved or stroked over the skin of the part to which the current is to be applied. In this stroking, a certain, even, constant pressure should be exerted. As in the former instance the current strength should be very gradually increased, and at its completion the current intensity should again be reduced as much as possible before removing the electrode. This method has a stimulating effect, especially upon the nervo-muscular tissue of the part.

The positive electrode is preferably held stationary at some indifferent part, as in the right hand when treating the lower extremity. The cathode or negative electrode is applied and reapplied alternately. When contact is made, a complete electrical circuit results; when withdrawn, this circuit is broken, and no sensation of a current can be felt by the patient.

A method which I prefer consists of an interrupting electrode handle. By pressing a small lever and again releasing it, the circuit is respectively made and broken. It is easy to manipulate, and the results obtained are most satisfactory.

Another method used is called the “voltaic alternative,” which consists in alternately reversing the polarity of the circuit by working the lever of the commutator or pole discharger. This current is employed for diagnostic purposes, as in atrophy of muscles of a part, etc.



## CENTRAL GALVANIZATION.

The object of central galvanization is to subject the whole central nervous system to the influence of the galvanic current. One pole, preferably the cathode, is applied against the epigastrium, whilst the anode is placed over the forehead for a period of time, depending upon the purpose for which the current is employed. As a rule, an application of five minutes duration may be accepted as a maximum. The positive pole should then be moved to the vertex, and thence along the course of the vagus and over the sympathetic area to the lowest extremity of the vertebral column. There may be found on the market a variety of portable batteries combining in one a galvanic, faradic, cautery, and diagnostic lamp battery. (Fig. 27.)



FIG. 27.—Galvanic, faradic, cautery, and diagnostic lamp battery.

## GALVANO-FARADIZATION.

By this term we mean the combination of both the galvanic and the faradic currents. This may be applied by employing four separate electrodes, or by connecting the secondary coil and the galvanic battery in one circuit, the negative pole of the one with the positive of the other, attaching the electrodes to the two extreme poles, and thus passing simultaneously both currents through the body.

## CAUTERY BATTERIES.

These are somewhat different from the batteries above referred to. They are subdivided into two classes,—the *thermo-cautery* and the *light*

*battery.* It is here our aim to increase the amperage and not the electro-motive force, hence it is necessary that the cells be arranged in the form of "parallels." For lighting a small incandescent lamp which requires a voltage of 6 c. p., the cells must be connected in a group of two, whereby the electro-motive force is halved, and the size of the cells doubled.

Accumulators seem to be more sensitive for this work, especially when there is a direct 110-current available for charging.

The use of the continuous current in diagnosis and as a therapeutic agent, will be found fully discussed in the chapters on Electro-Diagnosis and Electro-Therapeutics.

#### SINUSOIDAL CURRENT.

This current is alternating in type, and derives its name from the fact that its relation to time follows the law of series. It bears a great similarity to the ordinary, pure faradic current, in so far that its motor effect also varies according to the rate of alternations. When the alternations are 20 or less per second,—*i. e.*, when they are very slow,—the effect produced will be a contraction at each end of an alternation. When the alternations are more rapid,—say, 200 or 2000,—the muscular contraction becomes tetanic.

The sinusoidal current has a smooth and gradual variation. It is typically adapted for muscular stimulation, and by a properly constructed apparatus we may apply a slightly greater milliamperage than the pain-producing properties of the primary induction current would permit. The ease with which a large number of complete alternations per second of this smooth character can be obtained, renders the sinusoidal current an excellent nerve sedative.

## CHAPTER IV

### FARADIC, INTERRUPTED, OR INDUCED CURRENTS.

#### Principles of Induction.

ACCORDING to a natural law it is observed that when two distinct circuits are near each other, currents in the one will "induce" currents—or, more exactly, electro-motive forces—in the other. These induced currents are of momentary duration and appear only when the inducing current is made to vary, as is instanced when the current is made or broken. The current induced at the beginning of the inducing current is opposite in direction to the inducing current itself; and the current induced at the break of the inducing current has the same direction as the inducing current. The strength of a current so produced is proportional to the strength of the producing current plus the length of the wire subjected to the influence of the inducing current circuit. The action of the inducing current in the first coil is augmented if there be introduced within this coil a soft iron core, constituting the so-called electro-magnet.

Based upon these principles, first studied by Faraday in 1832, is the faradic or induction battery. This battery consists of one or more cells placed in circuit with a primary insulated wire surrounding the core, and with an automatic device for alternately breaking and making the cell current. Over the primary coil is slipped a bobbin having another coil of insulated wire wound around it. The secondary coil has no connection with the cell, deriving its current by induction, because of its being placed over and close to the primary coil and wire.

#### MEDICAL INDUCTION COIL.

The principles of the induction coil are well illustrated in Fig. 28. The current makes a circuit from the cell and passes through the platinum point, *A*, to the interrupter, and thence through the primary coil: the latter becomes an electro-magnet, which brings about the interruptions, through the mechanism of the hammer.

The heavy line indicates the primary interrupted current. The light line indicates the induced or secondary current.

The intensity of the induced current can be regulated by sliding the metallic tube in or out. The arrow  $D \longleftrightarrow I$  indicates that, when the sliding tube passes in the direction *D*, there is a decrease of current, because of a decrease in the area of the magnetic field, and vice versa.



The operation of the coil is as follows: The cell current proceeding from the carbon pole of the cell traverses the primary coil, and returns to the cell through the interrupter, the platinum points of the latter being in contact. In the act of traversing the coil, this current makes the core magnetic, which in turn attracts the small armature on the interrupter, breaking the cell current; the magnetism of the core now having disappeared, the spring returns to contact, when the process is again repeated. On closure of the cell current a reverse induction arises in the secondary coil, but this rises slowly on account of self-induction between contiguous windings of the primary coil. At the instant of opening the cell current, a direct current arises in the secondary coil of a much sharper curve of ascent because there is but little

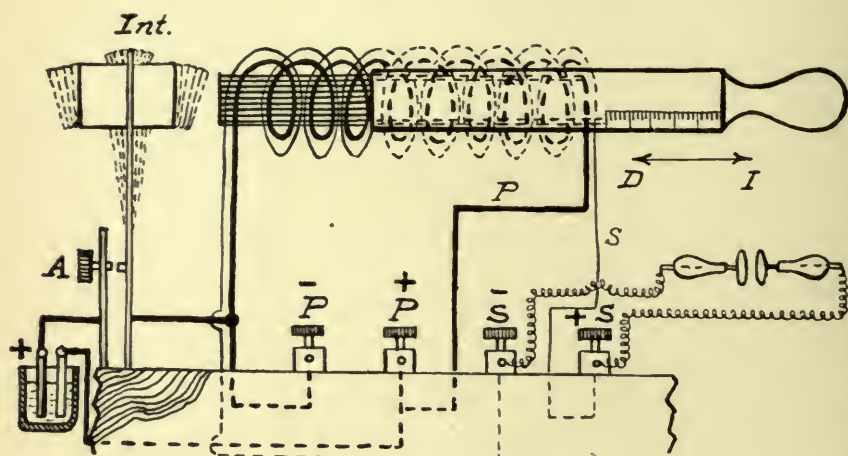

FIG. 28.—Medical induction coil.

self-induction to interfere with it. It is imperative that these coils shall not touch each other at a single point. Upon opening or closing the primary circuit, there will be established an induced current in the secondary coil. This type of electric current is produced by the use of a medical Ruhmkorff coil. The screw of the vibrating hammer should always be most carefully regulated. Some of the coils have two kinds of interrupters accompanying the outfit. One of these is slow, while the other is more or less rapid. Occasionally the hammer requires a slight touch of the finger in order to be started so as to form a circuit between the coil and cell or battery. The current produced by a faradic equipment is alternating in character, as may be readily demonstrated when applied to the tissues. Instead of a current from a cell, advantage is often taken of a direct 110-current, as is well illustrated in Fig. 29.



## INTERRUPTER OR RHEOTOME.

The interrupter which forms an essential part of the battery is the vibrating spring hammer of Neef. Many authorities condemn this form of rheotome, and recommend one which has double the ordinary spring length, both ends being attached to posts, to one of which is connected a tension-screw for regulating the rate of vibrations. The armature is attached to the middle of the brass spring and platinum plate for contact near the fixed post. Besides regulating the frequency and amplitude of the vibrations by the tension-screw, we regulate them also with the set-screw carrying the platinum contact point. This device gives easily the

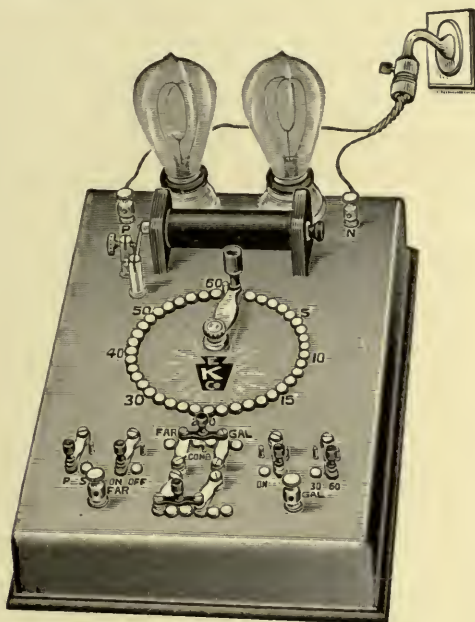

FIG. 29.—Galvanic and faradic lamp controller.

rate of vibration suitable for muscular contraction, and this is from 1 to about 3000 per minute. Vibrations above 3000 per minute are sedative. The highest stimulation is from 3000 to 4000 interruptions per minute.

## METHOD OF APPLICATION.

This method of electrization consists in placing one pole, generally the negative, at the feet or coccyx, while the other is applied to any part of the surface. The current may be applied (stable) stationary or (labile) moving; it may be increased or decreased in intensity according to the desire of the operator. The person applying it should have some experience, so that the very best results may be obtained.

## LOCALIZED FARADIZATION.

Localized faradization, as termed by Duchenne, or, more correctly, polar faradization, in contradistinction to the polar and bipolar method of galvanization, is applied in precisely the same manner as is the galvanic current. This localized or polar method has eliminated the unscientific terms "ascending" and "decending" currents. Nevertheless, we still speak of labile and stabile currents, one of the electrodes being moved over the surface or both being stationary, and of superficial and deep or penetrating currents; the former with a dry metallic electrode to the dry skin and superficial nerves, the latter with moist electrodes to the deep-seated tissues.

## AS A DIAGNOSTIC AGENT.

As a diagnostic agent, the induction current is of value for determining the increase or decrease of pathological excitability, and in differentiating between central and peripheral lesions. The tension current (fine coil) is sedative in character and is valuable in quieting hysterical suffering, thus affording differentiation between pain and hysteria in gynecological practice. The irritability of muscle is tested by determining the lowest power of the faradic current which will contract it, and then comparing with the normal side. In hysterical paralysis, the electro-contractility is usually normal, while electro-sensibility is lowered; in infantile paralysis voluntary contractility is increased, whilst faradic contractility disappears. So also in the reaction of degeneration, or where a nerve is cut in its continuity, and more or less atrophy or degeneration is found in both muscle and nerve.

## AS A THERAPEUTIC AGENT.

As a therapeutic agent the induction current acts on nerves and muscles, stimulating each into action or developing anæsthetic effects. Its use therefore is demanded in instances of nerve or muscle pain. Bipolar electrodes are most efficient in producing contraction of relaxed pelvic muscles, including the uterus itself; in other cavities and mucous membranes its employment is becoming general, through the brilliant results achieved by Apostoli.

## CHAPTER V

### CATAPHORESIS. HYDRO-ELECTRIC BATH.

#### I. Cataphoresis.

CATAPHORESIS is the introduction into the human body of remedial agents through the physical properties of the electrical current. Were the procedure electrolytic, either pole could be applied.

In 1859 Dr. B. W. Richardson<sup>1</sup> produced local anæsthesia by applying morphia to the anode. Since then various experimenters have succeeded in introducing many different medicaments by this process. Accurate doses are easily obtained. A piece of tissue paper or absorbent cotton is patterned to fit the electrode, and the desired quantity of the agent is placed upon it; the current strength varies from 3 to 20 milliamperes. Cataphoresis is mainly used to impress the skin and mucous membranes. Chloroform should only be employed as a counter-irritant, as its application produces a dermatitis. Helleborin and aconitin have been successfully used. Figs. 30, 31, 32, 33 depict various forms of cataphoric electrodes.

Rockwell believes that "the effects of the galvanic current upon nutrition are in part due to the cataphoric transfer of molecules of protoplasm and liquid from one cell to another, or from a cell to a capillary vessel in the path of the anodal stream, and since the diffusion takes place more rapidly and more quickly in direct proportion to the current strength, it behooves us to employ as many milliamperes as feasible in our galvanization of the atrophied and paralyzed extremities of poliomyelitis and chronic neuritis and peripheral nerve trauma."

Dr. James C. Gill,<sup>2</sup> in a paper read at the Thirteenth Annual Meeting of the American Electro-Therapeutic Association, September 23, 1903, entitled "Cataphoresis," said: "I believe that cocaine used with the aid of cataphoric action of electricity is the ideal method. Its use requires no great amount of skill and no expensive complicated outfit; an ordinary galvanic current with various sized electrodes is all that is necessary. The strength of the current or the solution used matters but little, as the stronger the solution the less time required to produce the desired effect, and a high amperage is undesirable because of the unpleasant sensation from the electric current. The advantages of cataphoric anæsthesia are these: 1. Complete anæsthesia without pain, which fact should not be

<sup>1</sup> Medical Times and Gazette, February 12 and June 25, 1859.

<sup>2</sup> Journal of Advanced Therapeutics, July, 1904.



underestimated, especially when dealing with an acutely inflamed and hypersensitive area, such as is frequently found in certain conditions



FIG. 30.—Peterson's cataphoric electrode.



FIG. 31.—Sectional view of the same.

*A* is a disk, made of metal that will not oxidize. The stem which passes through the hard-rubber cover *C* is held in place by nut *D*. It also holds the tip for connecting with the battery. *B* is a soft-rubber ring, which is held in place by *A*, and at the same time it insulates the skin from *A*, allowing the current to pass from *A* to the skin of the patient, through the medicated paper contained in the cavity formed by *A* and *B*. (Courtesy of Waite and Bartlett Manufacturing Co.)

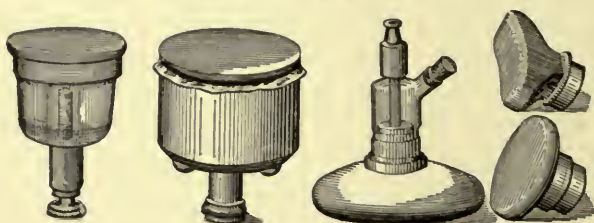

FIG. 32.—Three varieties of cataphoric electrodes.

The one furthest to the left consists of a glass jar, covered with a porous earthy material; the jar is filled with the solution desired. The middle electrode is that of Eisenberg, made of ebonite and covered with parchment. The right-hand one is the electrode of Dr. Strauss, which because of its small size can be utilized in the treatment of acne, sycosis, etc. (From the catalogue of Reiniger-Gebbert and Schall.)



FIG. 33.—Martin's cataphoric electrode.

It consists of a metallic plate over which is stretched a piece of parchment, which can be saturated through the tube with the required medicament.

necessitating the use of the knife. 2. No danger from constitutional disturbances, as the cataphoric action of the current brings the drug in



contact with the terminal filaments of the sensory nerves, and not into the absorbents as does the hypodermic injection, a sufficient amount is never taken into the general circulation to produce any noticeable effect. Personally, I have never seen any disagreeable symptom from its use in this way. 3. No danger of formation of drug habit. Patients do not know from any effect upon the nervous system that any drug has been used. 4. A large area may be anæsthetized, if necessary, with the absence of unfavorable symptoms."

Dr. G. Betton Massey,<sup>1</sup> "The Apostoli Treatment; Final Results in Some Cases of Fibroid Tumor of the Uterus," records the final results of electrical treatment in 101 cases of fibroid tumor, so far as they could be ascertained by personal inquiries, letters, and circulars. In some of the cases the treatment had stood the test for a period of sixteen years, while in none had less than three years elapsed. The tabulated results follow:

Cases in which the results are unknown.....	9
Cases resulting in anatomic and symptomatic cure.....	22
(Included in the list are 18 that disappeared by absorption, while 3 were extruded through the cervix in whole or in part, one was destroyed piecemeal by electrolysis.)	
Cases resulting in symptomatic cure only.....	53
(These include 12 with great reduction in size, 26 with slight reduction in size, and 15 permanently relieved of symptoms without change in size.)	
Total cases resulting in practical success.....	75
Cases resulting in partial or complete failure.....	26
	<hr/>
Total cases treated.....	101

Excluding the 9 cases in which the results are unknown it will be seen that the figures show 75 actual or practical cures, and 26 failures in 101 cases. In other words, 75 per cent. of the cases were successful and 25 per cent. were failures.

## II. The Hydro-electric Bath.

The hydro-electric bath is useful in many diseases for its stimulating and tonic effects as well as for its trophic influence. It is applicable in anæmia, chlorosis, rickets, rheumatism, gout, sciatica, etc.

The bath itself should be made of porcelain or glazed ware. The water should have a temperature of 90°-98° F. (32° to 37° C.). Two metal electrodes, that must always be kept clean and bright, are placed at the head and foot of the bath. These plates are attached to the battery by binding screws. The larger electrode is placed at the head of the

<sup>1</sup>Journal of the American Medical Association, May 21, 1904.

bath, and is usually 18 x 12 inches (45 x 30 cm.); the smaller electrode is 11 x 9 (28 x 23 cm.). In order to localize the current a movable paddle connected to the foot-piece is often employed. A wooden rest prevents the back and shoulders of the patient touching the head-plate. It is immaterial if the feet, with their thickened epidermis, touch the foot-board

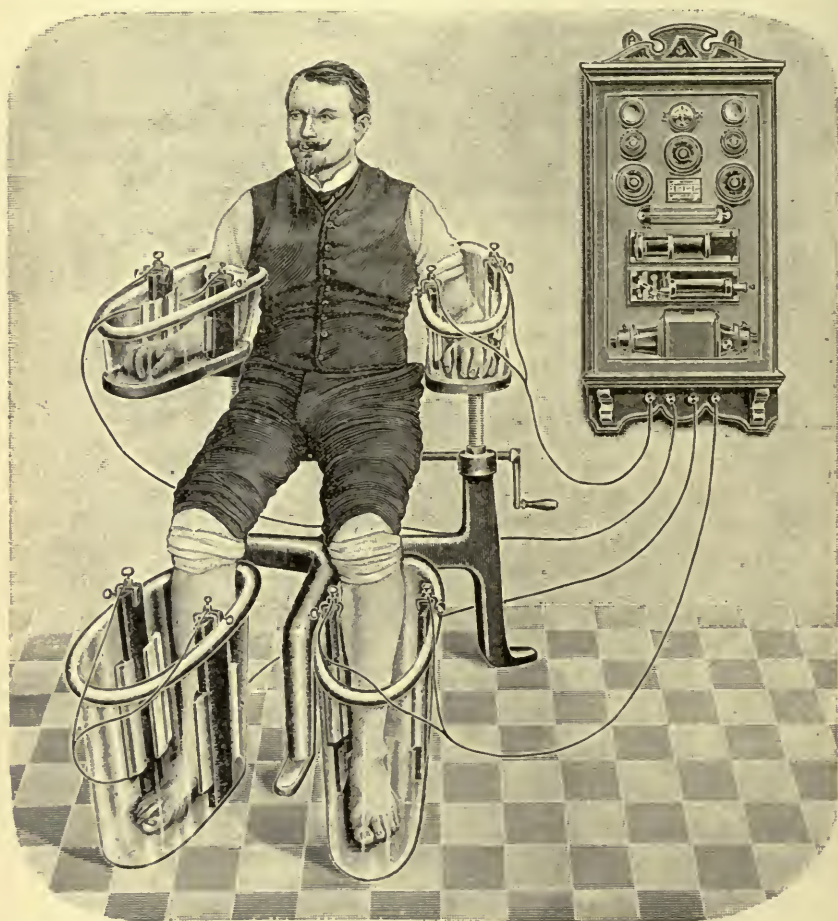

FIG. 34.—The four-celled battery of Schnée.

or not. A part of the current traverses the body, and the remainder passes through the water. The resistance in the bath depends upon its length, the depth to which it is filled, and the temperature of the water. As the current which traverses the water does not affect the patient, it follows that only so much water should be used as is required to cover the patient comfortably. No salt should be added to the water, as the latter thereby becomes a better conductor.

The duration of the bath should be ten minutes daily for the first week, but after that it should be given on alternate days. The choice of current will depend upon the condition present. Thus, in the early stages of general neuritis, in acute neuralgia, and in acute sciatica, the direct current is indicated. In gout, rheumatism, and arthritic conditions, the galvanic current is preferable. The induction-coil bath and the sinusoidal currents are useful where general nutritive effects are sought.

Among local baths may be mentioned :

THE ARM BATH.

THE MONOPOLAR AND DIPOLAR BATHS.

THE ELECTRIC DOUCHE BATH.

The *arm* bath is useful in paralysis of the muscles of the forearms and hands, in rheumatism and gouty affections, in chilblains, Raynaud's disease, etc. The constant current, the current from the coil, or the

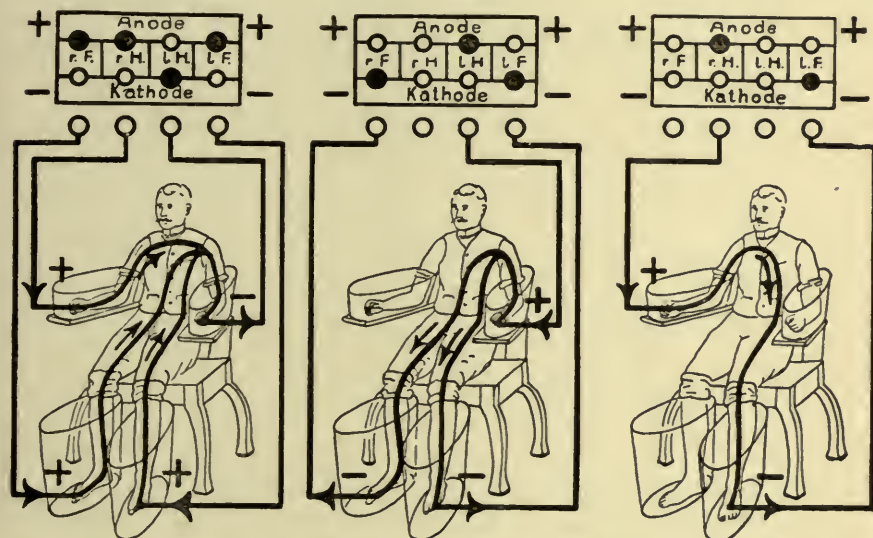

FIG. 35.—Diagrammatic view of the direction of current, as is illustrated in Schnée's four-celled battery.

sinusoidal current may also be employed. The bath can be arranged in any non-conducting vessel; stone-ware troughs, easily procurable and inexpensive, are valuable for the purpose.

In the *monopolar* bath only one electrode is immersed, the whole current passing from it to the patient. In the full-length bath, the patient grasps a metal conductor, usually a bar or handle which is covered with a piece of flannel, and secured above the water level. The current passes from the conductor to the hands, thence to the body, and finally to the water of the bath to reach the other conductor.



The *electric douche* bath originated with Trautwein in 1884.<sup>1</sup> Dr. Guyénot,<sup>2</sup> of Aix les Bains, has described a method of electrical application by the means of douches. The current is led to and from the patient by two streams of water, the conductors being connected to the nozzles through which the water flows, the jets of water carrying the current to the whole surface of the body or to the special part desired. Those interested in this method will find a detailed account in the original paper.

Dr. Schnée's four-celled battery is convenient and practicable for hydro-electrotherapy (Figs. 34 and 35), in that the patient's extremities are alone exposed without additional disrobing. It is comfortable to the patient, the current is regulated by a switch-board, and the parts immersed allow of a large area for cataphoresis. Duration of the bath 10 to 15 minutes. Current 5 to 30 ma. By means of this bath elimination of metallic poisons from the body has often been accomplished.

<sup>1</sup>Zeitschrift f. klin. Med., viii., p. 279, 1884.

<sup>2</sup>Revue Internationale d'Électrothérapie, June, 1894.



## CHAPTER VI

### ELECTRO-DIAGNOSIS.

THE examination of the motor nerves and muscles is of paramount importance in electro-diagnosis, consisting in localizing the current with the requisite intensity upon these parts.

The following rules should be followed: Apply one and only one pole for each irritation; the effect of the other pole should be repressed as much as possible.

For the local irritant effect use the active or irritant electrode; the other is termed the indifferent electrode.

Have the active electrode as small as possible so as to secure the greatest density of current.

Have the indifferent electrode as large as possible, so that the density may be slight and ineffective. Place the indifferent electrode upon the sternum, the back of the neck, or the small of the back.

The changes liable to occur in testing nerves and muscles are changes in the visible muscular responses. As there may be changes in the behavior of the muscles both to the coil and the cells, both forms of excitation are used in examining a muscle. The active electrode should be applied either to the muscle or near its motor point. In testing a muscle, the indifferent electrode should be applied to the skin with an even and firm pressure. The electrodes and the surface of the body should be well moistened. Water containing a saline diminishes the resistance of the skin, but offers the disadvantage of acting upon the electrode. With some of the small muscles of the hands and feet, it is convenient to apply both electrodes over the part, so that the current may pass directly through.

#### The Motor Points.

These are the points to which the testing electrode should be applied, in order to effect contraction in the adjacent muscle, or they are the points at which the motor nerve trunks can readily be reached. The positions of the motor points vary somewhat in different individuals.

The motor point can be absolutely located only by experiment. Subcutaneous fat acts as a barrier, and the examination of the deeper muscles is more trying than the superficial ones. The limb should be supported by the operator and the muscles relaxed as much as possible. Begin with a current capable of producing a small muscular contraction, applying the current for a brief period only.

Points favorable for the stimulation of nerve trunks.<sup>1</sup>

<sup>1</sup> The subjoined series of tables are taken from the work of H. Lewis Jones, M.D., on "Medical Electricity."

IN THE UPPER LIMB. (Figs. 36, 37, 38, and 39.)

1. *The median*, along the inner border of the biceps, and at the bend of the elbow.

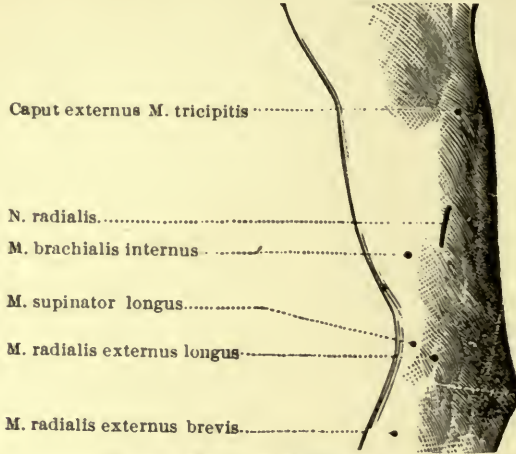

FIG. 36.—Motor points of the arm.

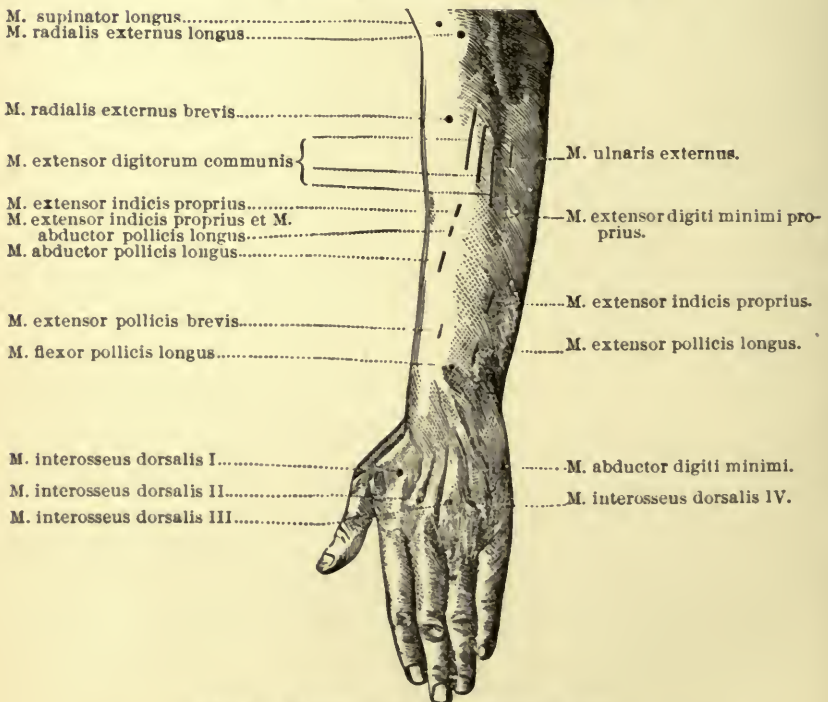

FIG. 37.—Motor points of the forearm and hand.

2. *The ulnar*, in the groove between the internal condyle and the olecranon.

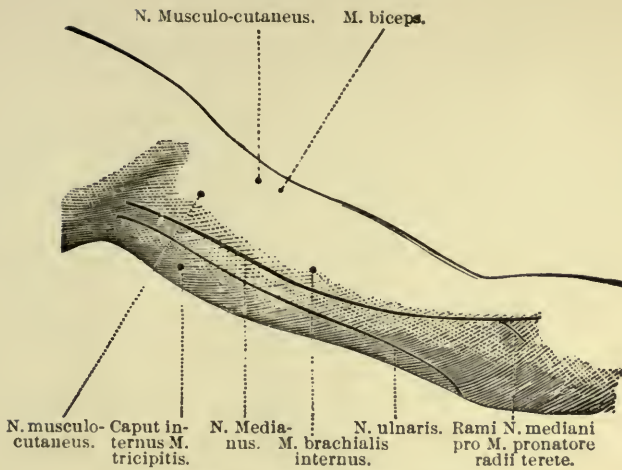

FIG. 38.—Motor points of the arm (front view).

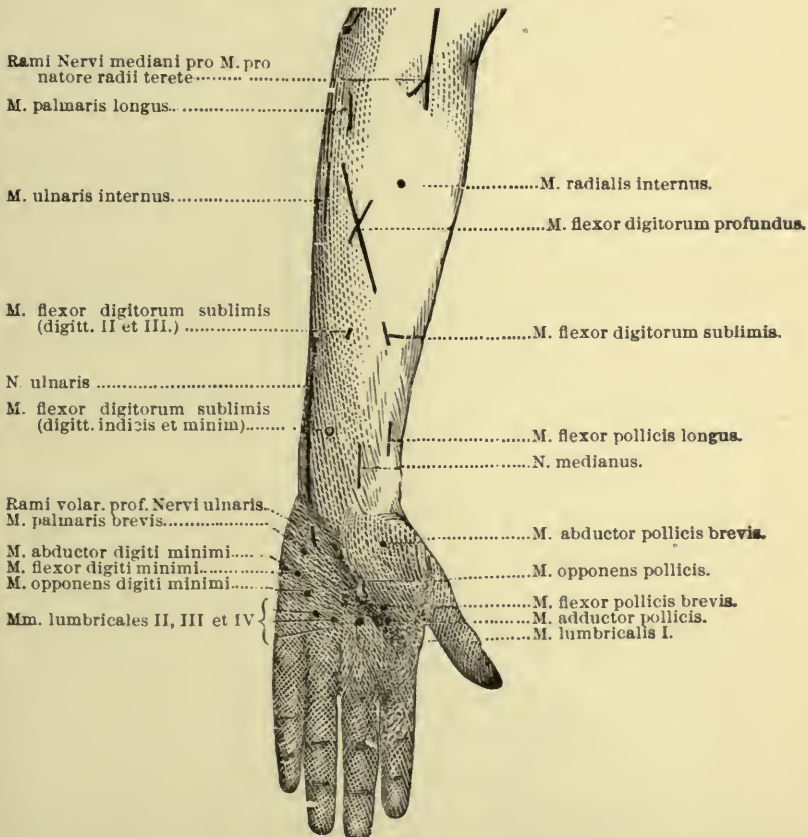

FIG. 39.—Motor points of the forearm and hand (front view).

3. *The musculo-spiral*, at the point where it emerges from the triceps, namely, on the outer side of the upper arm about the junction of the middle and lower thirds.

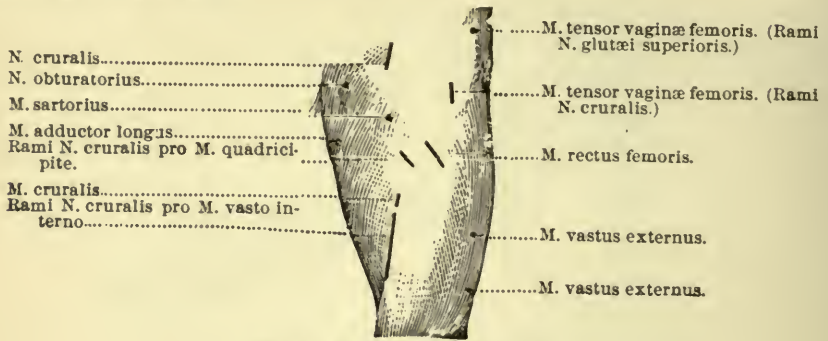

Fig. 40.—Motor points of the thigh.

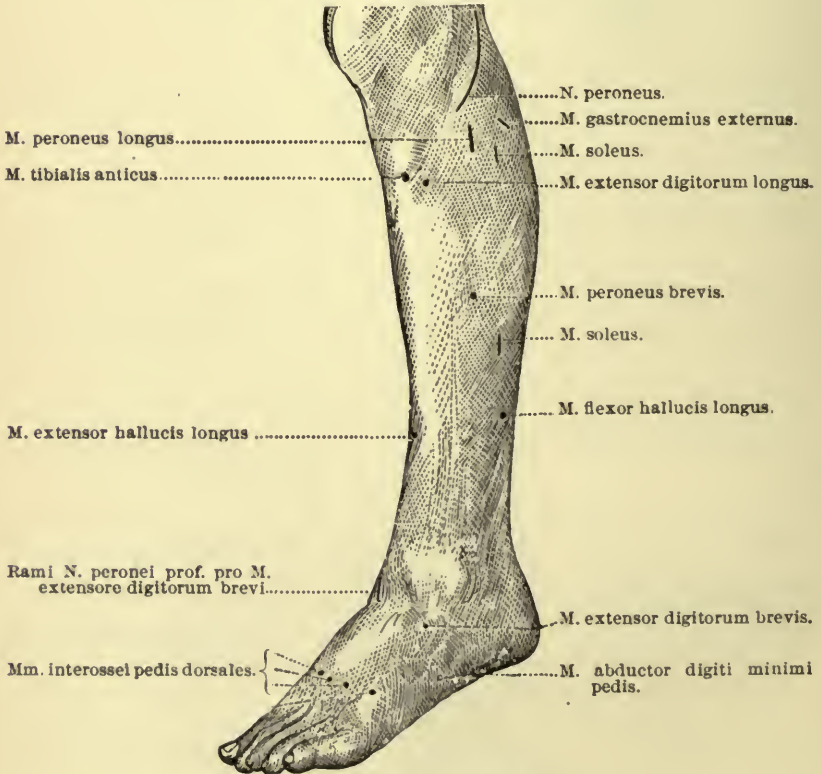

Fig. 41.—Motor points of the leg and foot.

4. *The musculo-cutaneous*, between the biceps and coraco-brachialis muscles.



5. *The long thoracic* (serratus magnus), on the inner wall of the axilla.

6. *The supra-clavicular point* of Erb. "At a spot one inch above the clavicle, and a little externally to the posterior border of the sterno-mastoid, immediately in front of the transverse process of the sixth cervical vertebra, a simultaneous contraction can be produced in the deltoid, biceps, coraco-brachialis, brachialis anticus, and supinator longus." This is a motor point for the fifth and sixth cervical roots before they reach the brachial plexus.

IN THE LOWER LIMB. (Figs. 40, 41, 42, and 43.)

7. *The anterior crural*, in the fold of the groin just outside the femoral artery.

8. *The sciatic*, just below the gluteal fold at the back of the thigh.

9. *The internal popliteal nerve*, in the popliteal space, and to the inner side of the tendo Achillis.

10. *The peroneal nerve*, just above the head of the fibula, beside the biceps tendon.

IN THE FACE. (Fig. 44.)

11. *The facial*, through the cartilage of the lower surface of the meatus auditorius. Its chief ramifications can be reached where they emerge from the parotid gland. Erb chooses for stimulation three main branches of the facial: (a) for muscles above palpebral aperture; (b) for muscles in front of upper jaw, between the orbit and the mouth; (c) for muscles of the lower jaw. He tests each of these in two places, first at points just in front of the ear, and secondly for (a) at the temple, for (b) at anterior extremity of zygomatic bone near its lower border, for (c) at the middle of the inferior border of the horizontal ramus of the lower jaw.

12. *The fifth*, at the supra-orbital foramen, at the infra-orbital foramen, at the foramen mentale, on the side of the tongue.

IN THE NECK. (Fig. 44.)

13. *The spinal accessory*, at the top of the supra-clavicular triangle, where the nerve pierces the sterno-mastoid.

14. *The phrenic*, on the outer edge of the lower part of the sterno-mastoid.

15. *The hypoglossal*, along the upper border of the great cornu of the hyoid bone.

16. *The recurrent laryngeal*, along the outer border of the trachea.

17. *The pneumogastric and glosso-pharyngeal*, along the track of the

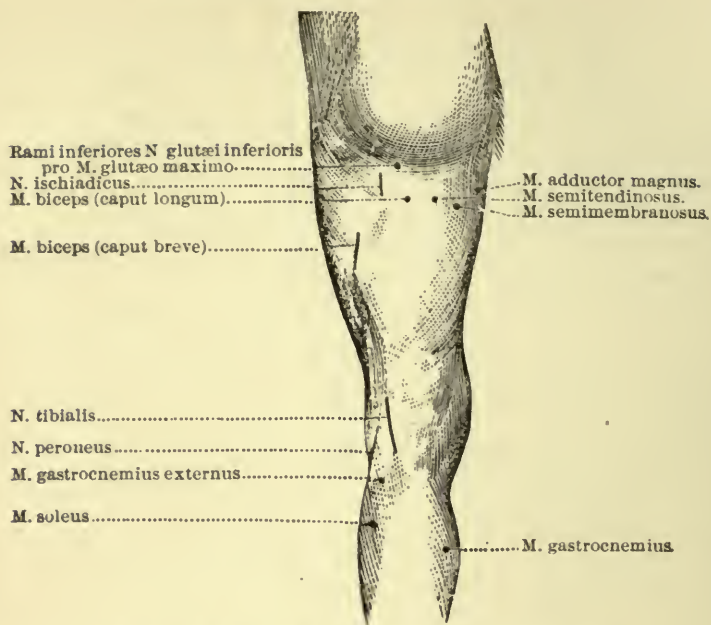

FIG. 42.—Motor points of the thigh and leg (posterior view).

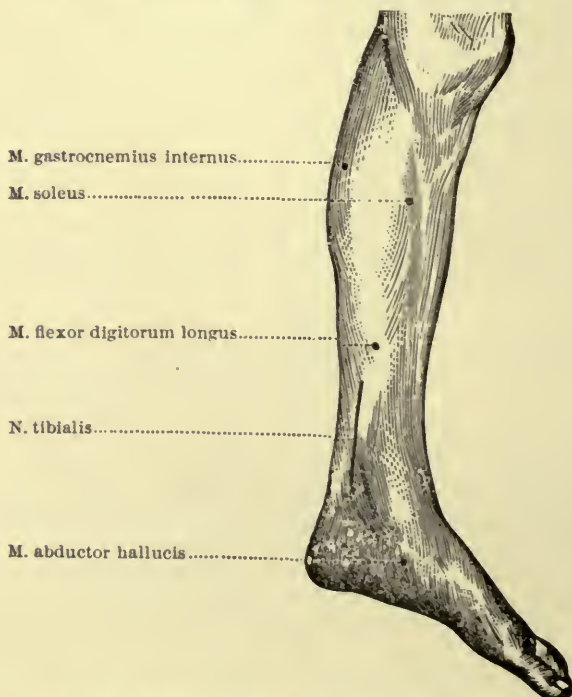

FIG. 43.—Motor points of the leg and foot (inner side).

carotid artery just below the angle of the jaw. Fig. 45 illustrates the motor points of the chest and abdomen.

When paralysis affects certain groups of muscles, and difficulty is

1, M. corrugator supercilii; 2, M. compressor nasi et pyramidal. nasi; 3, M. orbicular. palpebr.; 4, M. levator lab. sup. alaeque nasi; 5, M. levator lab. sup. propr.; 6, M. zygomatic. minor; 7, M. dilat. narium ant. et post.; 8, M. zygomatic. major; 9, M. orbicularis oris; 10, Ram. comm. pro Mm. triangul. et levator menti; 11, M. levator menti; 12, M. quadratus menti; 13, M. triangul. menti; 14, Ram. subcutan. colli N. facialis; 15, Ram. cervical. pro Platysmat.; 16, M. sterno-hyoideus; 17, M. omo-hyoideus; 18, M. sterno-thyroideus; 19, M. sterno-hyoideus; 20, M. frontalis; 21, Mm. attrahens et attolens auriculæ; 22, Mm. retrahens et attoll. auriculæ; 23, M. occipitalis; 24, Nerv. facialis; 25, Ram. auricular. post. prof. N. facialis; 26, M. stylo-hyoideus; 27, M. digastricus; 28, Ram. buccales. N. facialis; 29, M. splenius capitis; 30, Ram. subcutan. maxill. infer.; 31, Ram. ext. N. accessorii Willisi; 32, M. sterno-cleido-mastoideus; 33, M. cucullaris; 34, M. sterno-cleido-mastoideus; 35, M. levator anguli scapulæ; 36, N. thoracic. post. (Mm. rhomboidei); 37, N. phrenicus; 38, M. omohyoideus; 39, N. thoracic. lateralis. (M. serrat. magn.); 40, N. axillaris; 41, Ram. plex. brachialis (N. musculocutan., pars N. mediani); 42, N. thoracic. ant. (M. pectorales).

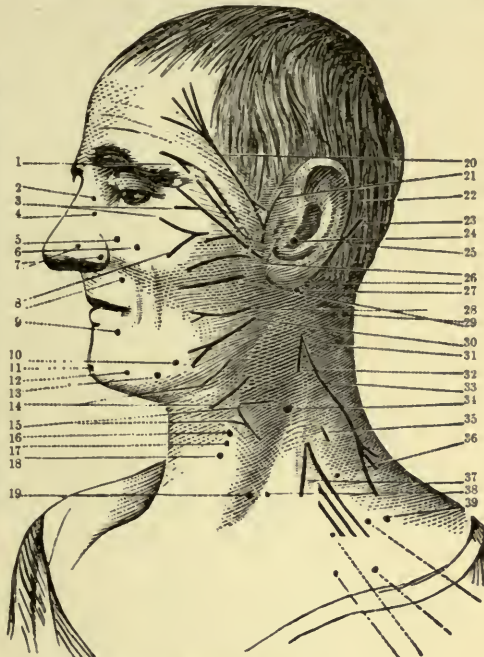

FIG. 41.—Motor points of the head and neck.

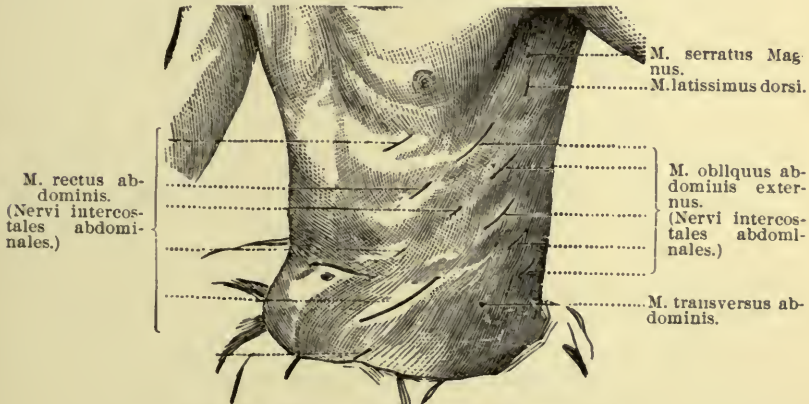

FIG. 45.—Motor points of the chest and abdomen.

experienced, as it frequently is, in tracing the nerve supply of the muscles involved back to their spinal roots, advantage may be gained by employing the table by Dr. Allen Starr.<sup>1</sup>

<sup>1</sup> Brain, 1894.



## SEGMENTS.

*4th cervical.*—Diaphragm, levator anguli scapulæ, deltoid, rhomboids, spinati, biceps, supinator longus.

*5th cervical.*—Rhomboids, spinati, teres minor, deltoid, pectoralis major (clavicular portion), biceps, serratus magnus, supinator longus and brevis.

*6th cervical.*—Latissimus dorsi, pectoralis major, serratus magnus, pronators, biceps, triceps, brachialis anticus, extensors of the wrist and fingers.

*7th cervical.*—Teres major, latissimus dorsi, subscapularis, pectoralis major and minor, triceps, flexors of the wrist and fingers.

*8th cervical.*—Flexors of the wrist and fingers, extensors of the thumb, intrinsic muscles of hand.

*1st dorsal.*—Extensors of the thumb, intrinsic muscles of the hand (thenar, hypothenar, interossei).

For the lumbar enlargement Dr. de Watteville<sup>1</sup> gives the following distribution:—

*3d lumbar.*—Ilio-psoas, sartorius, adductors, extensor cruris.

*4th lumbar.*—Extensor femoris et cruris; peroneus longus; adductors.

*5th lumbar.*—Flexors and extensors of toes, tibial, sural, and peroneal muscles, extensors and rotators of thigh, hamstrings.

*1st sacral.*—Calf, hamstrings, long flexor of great toe, intrinsic muscles of foot.

*2d sacral.*—Intrinsic muscles of the foot.

Dr. Herringham<sup>2</sup> has also tabulated the results of numerous dissections of the brachial plexus in new-born infants as follows:

## USUAL NERVE SUPPLY.

*3d, 4th, and 5th cervical.*—Levator anguli scapulæ.

*5th.*—Rhomboids.

*5th, or 5th and 6th cervical.*—Supraspinatus, infraspinatus, teres minor.

*5th and 6th cervical.*—Subscapularis, deltoid, biceps, brachialis anticus.

*6th cervical.*—Teres major, pronator radii teres, flexor carpi radiales. Supinator longus and brevis. Superficial thenar muscles.

*5th, 6th, and 7th cervical.*—Serratus magnus.

*6th or 7th cervical.*—Extensores carpi radiales.

*7th cervical.*—Coraco-brachialis, latissimus dorsi, extensors at the back of the forearm, outer head of triceps.

*7th and 8th cervical.*—Inner head of triceps.

<sup>1</sup> Lancet, July 14, 1883.

<sup>2</sup> Proc. Roy. Soc., March, 1866.



7th, 8th, and 1st dorsal.—Flexor sublimis and profundus, flexor carpi ulnaris, flexor longus pollicis, and pronator quadratus.

8th cervical.—Long head of triceps, hypothenar muscles, interossei, deep thenar muscles.

The *pectoralis major* from 6th, 7th, 8th, and 1st dorsal.

The *pectoralis minor* from 7th, 8th, and 1st dorsal.

### Hints for Practical Testing.

Always begin testing with the induction coil and finish with the cells. Do not use very strong currents from the coil. If the muscles do not respond to these currents, increase the strength of the latter. The operator should first apply the current to his own person, so as to reassure the patient. With battery currents start with about 16 cells for the limbs and 8 cells for the face. The testing electrode should be the cathode. If upon passing no noticeable contraction is discerned in the muscles, increase the number of cells, upon the first closure contraction, look for the most effective spot for stimulating the muscle, and compare the ACIC with the CCIC. Observe the character of the contraction, whether quick or sluggish. Compare the direct with the indirect stimulation through the nerve trunk; compare the reactions obtained with those of the unaffected side.

Disease or injury may cause quantitative changes or changes in the amount of reaction to a stimulus, the quality of the reaction remaining unaltered, as is exemplified in simple increase of excitability and simple decrease of excitability to coils and cells.

In unilateral disease, the recognition of increased or decreased excitability is easy when this increase or decrease is marked; but when slight, there are many disturbing factors that may lead to an error of judgment.

With the battery current, the galvanometer is a reliable guide. Unequal pressure of the electrode, when comparing two points, may cause an apparent difference in irritability. The resistance of the skin is likewise inconstant during a test.

Increased irritability usually occurs in those conditions presenting increased reflexes, as in chronic myelitis, in degeneration of the lateral columns, in hemiplegia, and in tetany.

Decreased irritability is evidenced in many diseases, offering qualitative changes also when the condition is more severe. Thus in neuritis we may observe either qualitative or quantitative changes, according as the attack is mild or severe.

Qualitative changes are changes affecting the quality of the reaction. This includes the reaction of degeneration, both complete and partial, also the myotonic reaction, etc.

**Reaction of Degeneration. (De. R.) or (R. D.)**

This term was proposed by Erb, to signify the series of changes occurring in electrical irritability, both qualitative and quantitative, owing to a certain definite morbid condition of nerves and muscles. The effect of the faradic current diminishes and disappears, but with the galvanic current, decided changes are manifested. Lesions of motor nerves, either at the spinal centre or in the course of peripheral distribution, of sufficient importance to produce paralysis, will rapidly show pronounced galvanic and faradic changes. The nerve will exhibit a progressive diminution of electrical excitability, and a few days subsequently it will have ceased entirely. Rarely a fortnight elapses before complete cessation of excitability is noted. The point of departure is always at the extremity, nearest the injury or lesion, degeneration proceeding thence toward the periphery. When reparative action has begun, excitability returns, recovery showing itself at the point of beginning degeneration. Frequently muscles may respond to the patient's will, but they do not respond to electrical currents; showing that while the nerve will transmit the voluntary impression, it will not necessarily transmit other impressions.

**DEGENERATION OF MUSCLES.**

In degeneration, muscles differ from nerves in their electrical reactions. With the faradic current, however, the reactions are identical both in quality and quantity. The faradic current has no effect on muscle tissue, save for the nerve supplying it. With the galvanic current, muscular tissue for the first few days contracts, with a somewhat lessened activity; its response to a certain strength of current is not so marked as in the normal condition. For several succeeding days, the irritability of the muscle is increased. This may last for weeks, and sometimes during this condition a change in the normal sequence of contraction occurs, the contractions changing in character as well as in quality. They assume a slow tetanoid form, which continues during the flow of the current, the strength of the current required being notably small. Soon in the stage of degeneration the  $\text{AnClC} = \text{CaClC}$ , and a little later exceeds it; this is accompanied by the  $\text{CaOC}$  gaining upon the  $\text{AnOC}$ , but never being equal to it. Thus we obtain the following formula for the normal muscular reaction to galvanism:



For the reaction of degeneration, the formula:

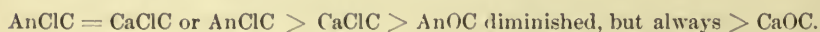

### PARTIAL REACTION OF DEGENERATION.

This term is applied to cases in which contraction is evidenced to some degree by the coil, but to the battery current the response is sluggish.

The existence of partial reaction of degeneration makes it necessary, when testing, always to corroborate the results obtained from the coil by employing the battery current. In partial reaction of degeneration there is found an alteration in the coil reactions, but this may be overlooked, and thus, conclusions arrived at from the presence of coil reactions would be wrongly interpreted. The degree of sluggishness of contractions may vary within wide limits, the reaction to the coil may be faint or very strong. By some it is held that partial reaction of degeneration represents a changing state of the nerve or muscle, and that a change to complete reaction of degeneration on the one hand, or to a normal reaction on the other, may be looked for in cases showing partial reaction of degeneration.

### THE SENSORY SYSTEM.

Little can be said on the subject of alterations in the electrical reactions of the sensory nerves, and but faint light can be thrown on the irritability, conductivity, location, etc., of the sensory nervous system. An increase in the impressions conveyed by the cutaneous filaments of the sensory nerve-fibres indicates electrical cutaneous hyperæsthesia, while impairment of this function, corresponding largely with the definite reactions of the motor system, constitutes electrical cutaneous anæsthesia. In diseases involving the sensory tracts of the cord, the diagnosis is materially aided by finding this anæsthesia and hyperæsthesia.

### NERVES OF SPECIAL SENSE.

Under this heading we shall only notice the auditory nerve, which allows of material aids in diagnosis, through its irritability in tinnitus aurium. Like motor nerves, the auditory responds more readily to cathodal than to anodal stimulation, the response being the production of a subjective sensation of sound; in certain abnormal conditions the auditory nerve answers to electrical currents more readily than it does in health. In these cases it is contended that a state of hyperæsthesia exists in the nerve, and that tinnitus is an expression of that state. To test the auditory nerve, use a bifurcated electrode applied to both ears at once. By this method there is less likelihood of provoking giddiness. If a binaural stethoscope is used as a temporary expedient, the lower portion should be removed, and the tubes closed up with small corks; the battery wire is attached to the metal and the other electrode is placed indifferently.



## CHAPTER VII

### ELECTRO-PHYSIOLOGY.

THE diagnosis of pathological conditions can in many instances be more accurately investigated by a thorough preliminary understanding of a study of the electrical current influences upon the normal physiological functions.

#### INFLUENCE OF ELECTRICITY UPON MOTOR NERVES AND MUSCLES.

The motor nerves, when irritated by the galvanic or faradic current, give rise to a muscle contraction. According to Du Bois-Reymond :

“The absolute amount of the density of the current at any certain moment does not act as a stimulant to the motor nerves, but merely the change in its amount from one moment to another, *i. e.*, in the density ; these act so much more powerfully the greater they are in a unit of time, or, their amount being equal, the more rapidly they occur ; most powerfully therefore upon sudden closure and opening of the current.

“Thus the reason of the marked irritative effect of the faradic current on motor nerves at once becomes apparent ; whilst, on the contrary, a constantly flowing galvanic current, or a very gradual increase or decrease in the current strength, produces no stimulation whatsoever. If induction currents are applied to a motor nerve, a series of brief muscular contractions, corresponding to the strength of the induced current, will be produced ; these contractions necessarily being greater during the opening than during the closing current of the secondary coil. A long series of these irritations results in a tetanic contraction.”

#### PFLÜGER'S LAWS OF CONTRACTION.

“With *weak* currents in both directions, contraction occurs on closure alone, but none is produced on opening ; the contraction on closure of the ascending current is somewhat stronger than that of the descending.

“With *moderate* currents contraction occurs on opening and closing in both directions ; but the former are always weaker than the latter.

“With *very strong* currents (never employed upon human beings) contraction occurs on opening, but none on closure of the ascending current ; and it also occurs on closure, but not on opening of the descending current.”

These laws only hold good when the nerve is laid bare and well isolated.



In illustration of the above laws we need only refer to the irritative effect produced by the galvanic current, which occurs only at the poles, and starts from them, and note that the irritation upon closing the circuit occurs only at the cathode, and upon opening, only at the anode. Long ago it was proved that the irritant action of the cathode was greater than that of the anode; thus the irritation on closure is greater than at the opening, with the same intensity of current. Likewise the central part of a nerve is more irritable than the peripheral portion, and with very strong currents considerable resistance occurs at both poles and increases with the strength and period of closure of the current. Furthermore motor nerves are non-irritable to the transverse passage of the faradic or galvanic current, and a motor nerve which is still connected to a central organ has its opening contraction of the ascending current considerably later than when the (motor) nerve is isolated.

Thus far we have been dealing with electrical currents on motor nerves studied physiologically, but the results obtained are not analogous with the practical results obtained by the physician. The latter deals with nerves, surrounded by tissues of good conduction and which are followed by large numbers of threads of currents; illustrating the absolute futility of maintaining a uniform density of current in a nerve. The greatest density of current must occur directly at the electrodes. Because of the various threads of current, the direction of the latter must be omitted from consideration in applying electricity to the healthy human body.

In the polar method of examination, one electrode, called the "active," is applied closely to the nerve and then connected with either the anode (An) or cathode (Ca) of the battery. The other electrode, termed the "indifferent," is placed upon some distant part of the body, as the sternum, spine, epigastrium, etc. If the cathode is upon the nerve and the circuit is closed, the term "making a cathode closure" is employed, and is written CaCl; if the circuit is open it is designated "cathode opening," and is written CaO, and similarly with the anode.

Begin with a definite strength of current by examining CaCl in about three closures, at the same time studying the CaO, and thus also with the anodal contractions.

For the opening contraction, keep the current closed for a brief period, as the irritability on opening the circuit is thus augmented. By an increase of current, we gauge the degree of intensity of current for the various forms of contraction.

By this method it is readily demonstrated that with most of the motor nerves the cathode chiefly produces stimulation on closure, the anode principally on opening, and that the stimulant action of the cathode is much greater than that of the anode.

In medicine three stages of contraction are distinguished :

First stage (feeble current)  $\text{CaClC}$ .

Second stage (moderate current)  $\text{CaClC}'$  is stronger.  $\text{AnClC}$  and  $\text{AnOC}$  also occur and are for all practical purposes of about equal strength.

Third stage (strong current)  $\text{CaClC}''$  becomes tonic and equals  $\text{CaClTe}$ ;  $\text{AnClC}$  (and especially  $\text{AnOC}'$ ) becomes more powerful and at the same time weak  $\text{CaOC}$  occurs.

#### UPON VOLUNTARY MUSCLES.

Du Bois-Reymond's law of motor nerve stimulation holds equally good for muscle stimulation.

"Currents of very high duration occasion less reaction upon muscular tissue than upon nerves; but the summation of the individual contractions produced by each single induction stroke results in tetanus, as was observed in the excitation of nerves. The laws of muscular contraction produced by galvanism are analogous to those already formulated.

"Depending upon the strength of the current, living muscles react with more or less tetanic contraction to faradism, and with single contractions to individual contraction currents. This occurs so much more readily the nearer the electrodes are approximated to the points of entrance of the motor nerve-branches into the muscle, or touch these points (motor points) directly.

"The galvanic reaction of the muscles occurs in such a manner that they respond to stimulation with both poles, by a closure contraction alone, the opening contraction being absent, or obtained very exceptionally. To some extent, an isolated irritation of the muscles of the body by the galvanic current may effect a local galvanization, founded upon the same principles and methods as local faradization. Another very important group of effects are the modifying, irritability changing, electrotonic action, which are manifest in the electrical, thermal, or mechanical irritability of motor nerves (and muscles) during the passage and after the cessation of the current."

#### ELECTROTONUS.

When a galvanic current is passed longitudinally along the course of a motor nerve, the nerve changes its irritability along its entire length, which is especially pronounced in the vicinity of both poles. At the cathode and its vicinity there is an increase in the electrical, mechanical, and thermal irritability, and that portion of the nerve is said to be in a state of "catelectrotonus;" at the anode and its vicinity it is decreased, whence the term "anelectrotonus." Both increase with the duration and intensity of the polarizing current, and touch one another

in an indifferent point of the intrapolar region. Upon breaking the current, the negative modification of the irritability of the anode (anelectrotonus) is immediately changed to a marked positive, requiring some time for its disappearance; at the cathode, a brief negative irritability rapidly followed by a vigorous positive modification, with an increase of irritability which gradually returns to the normal. Thus after breaking the current, there remains a normal or less prolonged increase of irritability at both poles.

#### SENSORY CUTANEOUS NERVES.

The application of the galvanic current to the skin produces a pricking followed by a burning sensation, which may increase, and cause intense pain. Possibly these sensations may in a large measure be due to the effects produced by the chemical substances liberated at the surface of the body by electrolysis; many asserting that the reaction of the sensory terminal organs is not identical with the reaction observed in the conducting paths.

The sensory irritations appear not only in that part of the skin covered by the active electrode, but likewise in the area of distribution of that nerve or nerves lying in the territory of the electrode.

#### SENSORY NERVES OF MUSCLES.

These can only be studied satisfactorily when muscles have been exposed by wounds, or in complete anæsthesia of the skin. Every vigorous muscular contraction is accompanied by a distinct sensation, which has nothing in common with cutaneous sensibility, and which may increase to actual pain during tetanic contraction (electro-muscular sensibility). The sensation produced is in direct proportion to the degree of muscular contraction, and is usually described as dull and tensile; it is likewise produced with strong galvanic currents as soon as they produce tetanic muscular contractions.

#### UPON THE SPECIAL SENSES.

To the galvanic current, the special senses respond with readiness by means of their specific sensations, the latter being dependent upon the influence of both poles. The optic nerve or retina reacts quickly to the galvanic current. Pass a current through the temples or cheeks and upon making or breaking the current a flash of light will appear. Apply a stronger current some distance from the eye (as upon the neck or chest or back), and the same phenomenon resulting illustrates the great sensitiveness of the retina to galvanic currents. The muscular tissue of the iris promptly responds to the faradic current; even the pupillary



sphincter can be made to contract independently, which may also be accomplished by stimulation of the motor oculi and the cervical sympathetic nerves.

The auditory nerve being very deep seated, its excitation can only be effected by a current that must be so strong as to produce most unpleasant associated phenomena. Galvanization of this nerve is accomplished by placing a large moist sponge electrode immediately in front of the auditory canal, pressing slightly upon, but not occluding the tragus. The indifferent electrode is placed upon the back of the neck. The strength of the current being increased, repeated cathodal closures, at times  $AnCl$ , are made, or if the irritability is very slight, repeated changes of polarity are to be instituted. The normal auditory apparatus therefore, only gives a sensation at closure upon irritation with the  $Ca$ , and only on opening upon irritation with the  $An$ . Healthy individuals usually hear sounds described as whistling, buzzing, hissing, or roaring. The  $AnO$  reaction is, as a rule, feeble and short. By an increase in the strength of the current, the auditory sensations increase in intensity, distinctness, and duration, and assume a more musical and whistling character.

By the galvanic taste is meant the peculiar acid, salty taste which is produced by placing the simplest galvanic element (a piece of zinc and copper) on the tongue, or by passing stronger currents through the cheeks, throat, temples, etc.

If two medium electrodes be placed upon the cheek, gustatory sensations appear at both poles. The sensation is more marked at the anode, where it is metallic, alkaline or perhaps very acid. At the cathode it is milder, biting and salty. The sensation is present at making, breaking, and during the passage of the current.

On the olfactory nerve, galvanic stimulation is little understood. By some it is said to produce a phosphorus-like odor.

#### UPON THE SYMPATHETIC SYSTEM.

The study of the galvanic current upon the sympathetic system needs to be further prosecuted. Physiologists are too problematic in their deductions as to the functions of the sympathetic nerves and their interposed ganglia, to lead to other than hypothetical conclusions.

Faradization of the cervical sympathetic causes contraction followed by dilatation of the vessels of the corresponding side of the head and face; slight exophthalmos, dilatation of the opposite pupil, and an accelerated action of the heart. Galvanization of the cervical sympathetic is much slighter and less certain.

In the human subject, this is a most difficult procedure. The cervical



sympathetic, being very deeply situated, has in its close proximity the vagus, the carotid with its vaso-motor fibres, the base of the brain, the cervical region of the cord, etc.

#### UPON THE SKIN.

Galvanization of the skin will first produce pricking and burning (as detailed under its action on the sensory cutaneous nerves), rapidly followed by an intense hyperæmia at both poles ; this redness may remain for hours, and be marked by the presence of papules or wheals, and finally succeeded by desquamation of the epidermis.

If the current strength be augmented, pallor of the surface is noted at the cathode, followed by a rosy redness ; the skin becomes infiltrated and surrounded by a deep border ; upon opening the circuit the redness persists. At the anode a pronounced scarlatinal color appears, the skin is not infiltrated but covered with small elevations ; upon opening the circuit, the redness persists for a long time, and is followed by desquamation.

#### UPON THE HEAD.

Vertigo is the earliest symptom manifested in galvanization of the head, when a strong current is passed transversely or in the antero-posterior direction (frontal bone to the back of the neck). The giddiness is most pronounced when the current is passed transversely. It has been maintained by some observers that ocular movements play a dominant part as a result of the severe vertigo, and that there is a disturbance of the muscular sense. With a strong transverse current passed through the mastoid processes, oscillation of the eyes occurs, the direction being that of the positive current. If the anode be on the left side, both eyes will be turned to the right. In some persons, galvanization of the head has resulted in nausea, vomiting, syncope, dulness or mental confusion.

#### UPON THE SPINAL CORD.

Large, flat electrodes should be placed upon the neck, very strong currents should be employed, and closure and opening should be resorted to. If the negative electrode be placed on the upper lumbar vertebræ, CaCl or change of polarity to Ca will produce vigorous contractions of the muscles supplied by the sciatic nerve, proving that the current has invaded the cord.

#### UPON THE ABDOMINAL ORGANS.

Vigorous faradization of the gall-bladder in cases of catarrhal jaundice, has caused the widely contracted gall-bladder to suffer a marked

contraction. Likewise in enlargements of the spleen, by direct faradization with large moist electrodes, or by employing two faradic brushes over the splenic area.

The pharynx and the velum palati may be faradized and galvanized by applying the positive electrode on the upper posterior part of the neck, and by rapidly passing the cathode over the lateral surface of the laryngeal area. Contraction of the muscular wall of the esophagus can be obtained by introducing electrodes, similar in shape to œsophageal bougies.

The stomach and intestines react to currents by slow contractions, which gradually spreading induces a peristaltic action. Faradism is more effective in these cases than is galvanism.

Vigorous faradization of the abdomen is often associated with a gurgling sound, and with the production of visible, palpable peristaltic movements of the stomach and intestines. The digestive tract may be reached by one electrode placed on the back, the other stable or slowly moving over the corresponding portion of the abdominal wall; or by the introduction of an electrode into the stomach or into the rectum, the other being applied labile or stable upon the external abdominal wall. Faradization of the bladder may be accomplished by introducing a urethral electrode as far as the vesical neck. Galvanic currents may likewise be employed. The contraction of the vesical sphincter and the urethral muscles is readily perceived.

#### ELECTRICAL CURRENTS IN DISEASES.

This is a most complicated process. Remak believed (and this view still obtains) that with the passage of the current there results a dilatation of the blood-vessels and lymphatics, causing an increased flow of blood and nutritive material, thereby favoring absorption of effete matter: that there is also an increased osmotic power of the tissues, changes in disassimilation and nutrition of the nerves, changes in the molecular arrangement of the tissues and the mechanical transportation of fluids from one pole to the other. To this series of changes the name "catalysis" is applied.

## CHAPTER VIII

### PRACTICAL APPLICATIONS IN DISEASED CONDITIONS.

#### I. Cutaneous Affections.

To a very large extent electric currents have been employed in the treatment of skin diseases, and, as the technic differs greatly in numerous cutaneous affections, it seems best to enumerate the various skin lesions, detailing under each the technic that seems most applicable.

##### ACNE.

In this affection Liebig and Rohe have obtained favorable results. I have seen a few cases improve by the use of hyperstatic sparks, and in one or two instances by the ordinary breeze.

##### ECZEMA.

The local effect of the static current is specially indicated in eczema, where the brush discharge may be most advantageously employed. Eczema yields to electrical treatment more easily than any other skin lesion. Rockwell recommends the application of the galvanic current applied either locally or centrally. Bordier (quoted by Hedley) reports a case of eczema thus treated, the result being very satisfactory. He uses the positive breeze, and this frequently reversed. The hydro-electric bath has given very satisfactory results in the practice of Gautier and Laret.

##### PRURITUS.

In pruritus the electric breeze is most useful. The duration of treatment should be between fifteen and twenty minutes. The metallic point should be held 10 to 15 cm. from the part.

##### ALOPECIA.

Local galvanization and also the static breeze are often beneficial in some cases.

##### SYCOSIS.

M. Boisseau du Rocher employed the following method for sycosis. Ten to fifteen silver needles attached to the positive pole are inserted into different points, the indifferent electrode is applied to the nape of the



neck, current three to four milliamperes, duration about ten minutes, application every second day. By this means the oxy-chloride of silver is formed, which is diffused into the tissues by the current. It may take three or four weeks, and 20 to 30 séances, to complete an absolute cure.

#### HYPERTRICHOSIS.

Since we are able to cause a general or local epilation with the X-rays, the process of electrolysis is gradually being abandoned. The method with the electric needle, formerly so prevalent, but tedious and painful in operation, has largely given way to the X-rays. I have succeeded in removing hair from the forearm by a weak but constant current, but it never should be forgotten that an acute and active dermatitis may thus be readily produced. If the hairs are few in number and scattered over the face, I believe the electric needle safer and less dangerous though more painful than the Röntgen rays. On the contrary, a burn with the X-rays may leave a life-long scar. For the face, therefore, it is advisable to resort to electrolysis.

The method of epilation is as follows: Place the patient on a high chair, take a fine needle which is attached to the negative pole of the galvanic current, while the patient holds the positive pole in the hand. A sponge of fair-sized dimensions and well wetted is attached to the latter electrode. The number of cells used is 5 to 8, so that a current of from 3 to 4 milliamperes is produced. A current of smaller amperage than this may be used; 1 to 2 milliamperes being often sufficient. The hair is seized with a pair of tweezers, at the same time the disengaged hand inserts the needle slowly into the hair-follicle. The patient squeezes the sponge to complete the circuit, which is indicated by small bubbles emanating from the point where the needle is inserted. The needle is usually allowed to remain 10 to 15 seconds. The patient now loosens the hold so as to break the circuit. An interrupting handle (Fig. 46) is



FIG. 46.—Interrupting needle-holder for electrolysis.

employed by many for this particular purpose. If the hairs are not loosened readily, defer the procedure until another time. The needle should be heated to redness, when its repeated introduction will be necessary for each individual hair. This method is for coarse hair. For the downy hair seen on the lip or chin in women, this method is unsatisfactory, and it is advisable to resort to the X-rays.



## PSORIASIS AND PITYRIASIS.

In both of these diseases, the negative pole of the galvanic current seems to be the more efficacious. Sometimes both poles, bearing large electrodes, are employed.

## RINGWORM AND SCLERODERMA.

Both of these diseases are markedly improved and often cured by the application of the galvanic current.

## PRURIGO.

Dry faradization may give relief from the intense itching, and at times will effect a cure.

## CUTANEOUS ANÆSTHESIA.

For this condition Rockwell believes faradization to be a specific. The electric brush should always be given a trial.

## HERPES ZOSTER.

Dr. Larat<sup>1</sup> reports several cases of acute herpes zoster in the eruptive stage with fever and unbearable lancinating pains, which were cured by the continuous current. The method is simple and can be employed by any physician owning a galvanic battery. The positive pole (represented by an electrode  $3\frac{1}{2}$  by 5 inches [9 x 13 cm.], covered with absorbent cotton and well moistened) is applied over the point of emergency of the affected nerve or nerves. The negative pole is connected to an electrode placed over the affected area. The absorbent cotton covering the electrode should be made large enough to cover all the vesicles, whether formed or forming. A current strength of from 6 to 10 ma. is employed for 25 or 30 minutes. The sensation produced by this current is that of a severe pricking, but it is well borne by the patient.

Two applications are made daily, but in case of failure at first, the author recommends that more be used. Under their influence the pain ceases, the eruption is arrested, the vesicles show a tendency to dry up, in fact all the local manifestations of the disease appear aborted. A cure is accomplished in from 24 to 48 hours, unattended by the usual subsequent neuralgia.

The probable explanation of these good results, is the accepted hypothesis, that herpes zoster is a trophic and sensory peripheral neuritis, in which the continuous current has the same curative effects as are manifest in other forms of peripheral neuritis.

<sup>1</sup> Revue Internationale d'Électrothérapie, October, 1904.

## NÆVUS.

Electric treatment should be instituted as soon after birth as is practicable. The needles may be alternately negative and positive, or all attached to one pole, and an ordinary pad electrode used for the other pole. Current may be employed up to 30 ma. Duration 5 minutes. Current must be gradually lowered to zero before withdrawing the needles.

## PORT-WINE MARK.

For these disfigurements use a number of needle-points attached to a disk, so that punctures may be effected simultaneously; the current is gradually turned on, allowing 2 to 3 ma. for each needle. This procedure is to be repeated every 3 weeks. The needles should be insulated, except at the point. The pole selected will vary with the vascularity, the prominence, and the extent of the nævus. With large blood channels use the positive pole; for flat spots some of the needles may be positive, some negative. Current 30 ma. Duration 10 to 15 minutes. The needles are left in place half a minute, so as to produce a slight eschar, they are then shifted; the whole surface being thus dealt with.

## MOLES AND WARTS.

The indifferent positive electrode is placed in the neighborhood of the growth. A needle attached to the cathode is inserted at its middle, or just above its base, parallel to the integument. Current about 5 ma. Allow the current to flow till the growth changes color and resembles a cluster of herpes. Then bring the current to zero. Time required is 2 to 3 minutes for each wart. In a fortnight the growth disappears, no scar remaining. Another method is to attach both poles to sharp needles and transfix the growth by the needles inserted parallel to the skin.

## FURUNCLES AND CARBUNCLES.

The local treatment of these growths by electricity is advocated by Marcus.<sup>1</sup> Previous to the appearance of suppuration, he opens the follicles of the affected area and introduces into them an epilation needle connected with the negative pole. Through this, a current of one to two milliamperes is passed at first, which is afterwards increased to ten. By slightly moving the needle around, the opening of the follicle is considerably enlarged, and a quantity of frothy serum is soon poured out, containing portions of tissue and numerous cocci. Then the needle is removed and the spot is carefully cleansed; the needle is again introduced

<sup>1</sup> Münchener medizinische Wochenschrift, May 23, 1905, No. 21.

and one or two milliamperes of current are again allowed to pass. The positive pole is now to be connected with the needle, and the current again raised to ten milliamperes. This causes the liberation of acid, which is always more energetic in its nascent condition. In two or three minutes the treatment is suspended and the surface again washed with water. Each affected follicle is treated in the same manner. If suppuration has already commenced, a larger needle is introduced into the follicles and moved around, until the entire greenish-yellow pus plug is broken up and disappears in foam. Then the positive pole is introduced and is again followed by the negative pole. A wet dressing is applied. This treatment is not applicable to very large carbuncles or extensive swellings.

## II. Muscular System.

### MYALGIA.

Employ local faradization with a mild current, either stabile or labile. Stabile galvanization with a mild current is often effective. Do not cease if the condition is unaffected or aggravated at first, but continue the applications. Static electricity by means of a roller electrode (Fig. 47) or general franklinization is frequently curative.



FIG. 47.—Roller electrode with insulated points for muscular faradization.

When employing the battery, Erb advises that a current up to 20 ma. may be used, applying the anode to the painful parts, and the séance terminated by a few reversals.

General electrization by means of the monopolar sinusoidal bath, faradic current applications, and static friction have also many advocates.

### WRITERS' CRAMP.

It is assumed that this disease is due to a weakness of the central nervous system. General galvanization of the spinal column and peripheral nerves should be resorted to. Faradic electricity is useful when applied directly to the muscles or groups of muscles of the hand and forearm. Seen in the very beginning, its course is often arrested by using the above forms of electricity.



Weiss<sup>1</sup> recommends the use of constant currents of 2 to 5 or 8 ma. for 15 to 25 minutes, with absolute rest from writing. Applications twice daily should be employed during the first weeks, diminishing later to 2 or 3 times a week. If extension is the chief symptom, the anode is to be applied to the palm; if flexion be marked, place the positive pole to the dorsum of the hand. Apply the cathode to the nape of the neck or the upper, inner surface of the arm and the anode to the sensitive parts for 10 to 20 minutes. Treatment should also be applied to the motor cortex and to the lower cervical region of the spine.

#### TORTICOLLIS.

In torticollis galvanization of the muscles of the affected side with currents of from 5 to 15 ma., and faradization of the muscles of the opposite side often prove most efficient. Galvanization of the sympathetic and the upper portion of the spinal cord should always be tried; but long-continued applications are contraindicated.

#### MUSCULAR CONTRACTIONS.

These may arise in hysteria, myelitis, meningitis, Pott's disease, or they may be reflex. These affections may be treated by galvanization of the affected muscles or of the antagonistic muscles with stable currents, or by galvanization of the head, spine, or sympathetic, etc.

#### SECONDARY CONTRACTURES OCCURRING IN HEMIPLEGIA.

Charles S. Potts<sup>2</sup> claims that in cases of hemiplegia where contractures have been allowed to develop, the patient's disability proceeds more from the deformity so produced than from muscular weakness. As the deformity is caused by the overaction of one set of muscles, usually the flexors, and is only aggravated by their stimulation, the indications are for measures which tend to relax the contracted muscles. This can be effected by the application of the positive pole of a galvanic current over the motor points of the affected muscles, and the indifferent electrode (negative pole) to any part of the sound limb, as over the sternum, or to the nape of the neck. Anelectrotonus should be aimed at. The current employed should be gradually increased from 0 to 5 or 10 milliamperes (about as much as the patient can bear), and kept at this maximum for five minutes, then gradually reduced to zero. Unless the current is gradually reduced to zero, catelectrotonus will follow and the condition of increased irritability thus set up will prevent the accomplishment of our object. After these applications of a continuous current, a

<sup>1</sup>Centralblatt für die gesamm. Therap., April, 1891.

<sup>2</sup>University of Pennsylvania Medical Bulletin, October, 1905.



weak faradic current should be employed, just strong enough to cause the muscles to contract moderately, about a dozen times and no more, as overstimulation defeats the end we have in view. The method is also of service as a preventive ; it may be started any time after the end of the second week following the seizure. Three treatments a week for several months should be given, followed by an interval (several weeks) of rest.

#### MYASTHENIA GRAVIS.

When tetanized by the interrupted current, the myasthenic muscle shows a rapid decrease in the degree of response to the current, evincing the normal physiological effect of fatigue with excessive and abnormal rapidity ; but after tetanization it remains just as responsive to a single closing shock, proving that the muscle is not diseased, but that the trouble resides in the nervous system.

### III. The Articular System.

#### SYNOVITIS.

In acute synovitis all forms of electrical applications are contraindicated. Subacute and chronic synovitis will be benefited by galvanization or faradization. When a cure cannot be effected by these means, the application of percussion static sparks is sometimes effective.

#### HYDRO-ARTHRITIS.

In the acute stage, as in synovitis, any form of electricity is irritating. In the subacute and chronic forms the active electrode (negative) of 20 to 25 ma. current should be employed. Each treatment should last no longer than 10 to 15 minutes. The indifferent electrode is placed on the back of the patient. The treatments should be made on alternate days, or every third day.

#### RHEUMATOID ARTHRITIS.

In this affection the sinusoidal bath is very beneficial. Dr. Roques<sup>1</sup> treats the affected joints by the electrolytic introduction of ions of salicylic acid into the surrounding tissues. Many electro-therapeutists believe that the beneficent action thus obtained is partially ascribable to a nutritional change in the diseased area.

#### CHRONIC ARTICULAR RHEUMATISM.

Chronic or subacute articular rheumatism frequently yields to static or galvanic treatment ; with the former it subsides gradually. The

<sup>1</sup> Arch. d'Électricité médicale, 1903, page 689.

condition will usually be benefited by local faradization. In very acute and painful cases, it is well to resort to anæsthetization with cocaine by the cataphoric process.

#### GOUT.

This disease is benefited by static electricity. This stimulates all the tissues of the part, improving the circulation, and in general doing much good. The continuous flow of current has been recommended, but I have failed to obtain any appreciable result from its employment. Lithium dipolar baths are prescribed by some authorities.

Guilloz<sup>1</sup> reports two severe cases of gout treated by monopolar electric baths containing lithium carbonate. He recommends currents up to 200 ma., and places the positive pole in the bath, the cathode of large size is applied to the patient's back. Similar reports by Bordier, in the same journal, are recorded.

It is usually maintained that the various currents applied directly to the joints will cause a stimulation of the tissues of the part, resulting in an absorption of the urates. Prolonged applications may aggravate the condition.

#### TUBERCULOUS ARTHRITIS.

Chanoz and Lévêque<sup>2</sup> report three cases, where the direct current proved of inestimable value in tuberculous arthritis. In one case Lévêque himself was the sufferer, and his treatment directed to his own person was eminently satisfactory. He believes that the negative pole is effective for relieving the superficial pain, the deeper parts being more influenced by the anode. The current should range from 25 to 50 ma. ; the electrodes should be of large size and placed on either side of the diseased joint.

#### FIBROUS ANKYLOSIS.

Apply large electrodes moistened in a solution of sodium chloride to each side of the joint. The negative pole should be placed nearest the joint. Use a current strength of 25 to 35 ma. Duration of each treatment from 10 to 25 minutes. Treatments 2 or 3 times a week. These electric treatments should be instituted only when there is no inflammatory process present.

M. A. Zimmermann<sup>3</sup> has reviewed the medical literature, and with the exception of a case treated by Leduc, of ankylosis of the elbow-joint

<sup>1</sup> Arch. d'Électricité médicale, June, 1899.

<sup>2</sup> Arch. d'Électricité médicale, 1903, page 264.

<sup>3</sup> Revue Internationale d'Électrothérapie, October, 1904.

reported cured by electricity, he has found nothing on the subject. Many surgeons recommend electricity in such cases for its action on the muscles surrounding the affected joints, but that is a form of electrical massage, and not an electrical application. Zimmermann has obtained good results, both in hospital and private practice, in cases of fibrous ankylosis, without pain or discomfort to the patient, by the employment of the continuous current. It is of importance to determine the nature and severity of the affection, because in cases of bony ankylosis no more good is accomplished by electricity than with other forms of treatment. However, in some cases, severe fibrous ankylosis in which massage and passive motion failed to afford relief, some degree of mobility was obtained; whereas in adhesions resulting from a gonorrhœal or other arthritis or from prolonged immobilization, cures were speedily attained. It should never be forgotten that radiographs are of inestimable value in making a differential diagnosis. The negative electrode should be placed over the most superficial part of the diseased joint, and the positive electrode on the part of the joint directly opposite, so that the lines of flux will pass in a straight line through the joint. The maximum intensity should be at least 40 ma., and the applications made every other day.

The number of applications necessary to effect a cure will depend upon the severity and chronicity of the affection; from 15 to 20 applications are required in cases of moderate severity.

#### IV. Digestive System.

##### VOMITING.

According to Apostoli and Bordier<sup>1</sup> two electrodes, each 2 cm. in diameter, are attached to the positive pole of the battery, and are placed over each pneumogastric nerve, between the insertions of the sterno-cleido-mastoid muscle. The indifferent electrode (100 sq. cm.) is placed upon the epigastric region attached to the negative pole. The strength of current should be from 5 to 10 milliamperes. If nausea is threatened, the current must be at once run up to 15 or 20 milliamperes and there maintained, so long as any ill effects are experienced by the patient. The duration of the séance varies from 4 to 20 minutes. Two sittings a day may be required at the beginning of the treatment.

##### DILATATION OF STOMACH.

Dilatation of the stomach is best treated by the static induced current. The outer cover of the Leyden jar is attached to an ordinary exciter, terminating in a small ball. This is applied over the uncovered

<sup>1</sup>Therapeutic Electricity, quoted by W. S. Hedley.



epigastric region; the distance of the pole of the machine should be such as to produce sparks at the rate of from 10 to 15 per second. The exciter is to be left on one spot for a couple of minutes, then displaced to another, and so on.

The duration of each treatment should be from 10 to 15 minutes; the usual requisite number of sittings is from 18 to 20, which should be given every second day.

#### NERVOUS DYSPEPSIA.

For this affection the galvanic current does most good.

The negative pole is usually placed over the epigastric region and the positive pole opposite the lumbar region. The strength of the current should be from 30 to 40 milliamperes; the duration of each treatment should be from 10 to 15 minutes; the number of treatments to bring about relief is from 8 to 10. A cure cannot be effected by this method of treatment.

#### CONSTIPATION.

In these cases, applications over the cord or the sympathetic system frequently produce most excellent results. Direct action on the digestive tract is often advantageous in promoting peristalsis.

*Method of Application.*—The patient is placed on the insulated platform, and the indirect static spark is applied to the various parts of the abdomen. This should be done by starting in the right iliac or inguinal region, gradually ascending to the liver, thence across the upper abdomen along the course of the transverse colon. This is followed by descending to the left side of the belly toward the upper part of the rectum. The object is to excite peristalsis in the normal direction.

The galvanic current is also applied for this condition, but in my experience the results obtained are not so satisfactory as with static electricity. A large-sized electrode (100 sq. cm.) is attached to the negative pole of the battery, and the electrode is applied to the belly in a similar manner as outlined above. The indifferent positive pole is applied to the lumbar spine. The faradic current may be applied instead of the galvanic.

Dr. Wahltuch<sup>1</sup> has reported seven cases in which the continuous current produced good results. He used a large sponge for the positive pole and an ordinary medium-sized one for the negative. The former he applied to the epigastrium, while the latter was slowly moved over the whole abdominal surface. The current was from 5 to 30 milliamperes. The operation was repeated on alternate days, from three to six weeks.

<sup>1</sup> British Medical Journal, 1883, vol. 11, 623.



A method, which has become popular in France, is the introduction into the rectum of a bougie electrode, the other pole being kept on the abdomen. To avoid the risk of electrolysis, and injury to the rectal mucous membrane, a combined douche and electrode has been devised.

#### ENTERITIS.

Dr. Zimmern<sup>1</sup> describes the excellent results he had obtained in mucous membranous enteritis by the use of the galvanic current applied externally to the abdomen. The treatment consists in applying the two electrodes in the right and left iliac fossæ, and using a current which starting from 0 is slowly and gradually brought up from 60 to 150 milliamperes, then as slowly again reduced to 0. The direction of the current is then reversed. Each treatment lasts about 20 minutes, and is repeated three or four times a week. No special attention is paid to the diet, though highly spiced food is of course forbidden. All enemas or cathartics are strictly prohibited, save with the following exceptions. If there is much constipation, two spoonfuls of castor oil are given every five days, or a large lavage of the intestine is to be practised if the castor oil does not produce the desired effect. Every day a very small enema of cold water (100 grammes) is given so as to start defecation reflexly, which is more or less dulled by the lack of sensibility of the mucous membrane.

According to Zimmern, the results obtained are not so much due to action on the muscular coating of the intestine as to action on the general circulation of the intestine. Out of 30 patients treated in this manner only 2 were refractory to the treatment, and 20 were absolutely cured, the remaining eight were only ameliorated. Dr. Delherm, another specialist in this line, describes the results obtained by the galvano-faradic treatment in 53 patients: 46 cases were very much ameliorated by the treatment, and 36 remained cured after a year.

René Desplâts, in a communication to the Société des Sciences Médicales,<sup>2</sup> stated that he had successfully treated twenty-five cases of mucous membranous colitis and spasmodic constipation by electricity of high voltage.

His method consists in placing two large metallic electrodes (tin plates, eight by ten centimeters) covered with several double folds of buckskin, moistened with warm water, upon the surface of the abdomen, one in each iliac fossa, and passing for ten minutes a current of sixty to seventy milliamperes, a little more or less, according to the tolerance of the patient. He also reverses the current at the end of each minute. If the sudden reversal causes too great a shock, he lowers the current even

<sup>1</sup> La Presse Médicale, No. 27.

<sup>2</sup> Journal des Sciences Médicales de Lille, April 14, 1906.

to zero before reversal. The resort to all purgative remedies is suspended during the treatment (which is repeated every two or three days), but if there is no spontaneous movement by the third day, he orders an enema, and this is gradually reduced. In atonic constipation the results were very satisfactory, even in children.

M. W. Peyser<sup>1</sup> employs a short, soft-rubber rectal tube in which is placed a metallic conductor; this is passed into the rectum, coiling in the ampulla being prevented if possible. The metallic conductor is attached to the positive pole. The tube is connected with the tube of a fountain syringe which contains saline solution. A large pad electrode, well moistened with saline solution or thoroughly soaped, is attached to the negative pole. While the solution is flowing, or after the syringe is emptied, the current is turned on and gradually increased in strength till from 15 ma. to 20 ma. are passing, or till the patient complains of burning at the negative pole. There should be no sensation from the current at the positive pole. The solution in the bowel acts as one of the terminals, thus spreading the current over a large extent of surface and permitting more current to be used. Similarly, the large pad permits increased amperage. In a varying period of time desire for defecation comes on—sometimes immediately, sometimes not for several hours. Should it come immediately, the patient should be persuaded to endeavor to continue the treatment for a while longer. The number of treatments required varies from six to ten, rarely less than the former or more than the latter. The tolerance of the patient should be the standard as to the quantity of current, some taking 20 ma. even at the first treatment, others never being able to take more than 12 ma. at any. The time of each treatment should be from fifteen to twenty minutes, seldom more, repeated daily till positive effects are obtained, and then at lengthening intervals till success is assured or failure manifested.

#### FISSURE OF THE ANUS.

The indifferent electrode is placed upon the abdomen, while the anode, covered with absorbent cotton saturated with a 10 per cent solution of cocaine (Massey), is applied to the fissure, using a 1 to 5 ma. current for several minutes.

#### AFFECTIONS OF THE RECTUM.

In paresis of the sphincter and in prolapse, the use of the faradic current has produced most successful results.

Dr. G. Betton Massey<sup>2</sup> treated a case of rectal prolapse in a middle-aged woman, by placing a felt-covered, flat electrode under the sacrum;

<sup>1</sup> Virginia Medical Semi-Monthly, Feb. 9, 1906.

<sup>2</sup> Therapeutic Electricity, W. S. Hedley.

the patient being in a dorsal position. An ordinary rectal electrode was inserted into the rectum, connected with the positive pole. With the proper regulation of the current, slow interruptions were effected, by touching one of the terminal posts with the tip of the conducting cord. This produced a good form of muscle contraction. Duration 10 minutes. No prolapse occurred after the first treatment.

#### HEMORRHOIDS.

The treatment of internal and external hemorrhoids by electricity is by no means easy. I have never seen any good accomplished by this agent, except in those cases where the electric current was employed cataphorically. Some have suggested the use of electric needles, and one or two succeeded in obtaining very satisfactory results. The electric caутery, of course, is a method for the relief of piles; the procedure is rapid, aseptic, and painless.

#### STRICTURE OF THE RECTUM.

The treatment of rectal stricture with electricity is identical with that of stricture of the urethra. The instrument used is larger (Fig. 48), and



FIG. 48.—Double rectal bulb electrode.

should also have a flat surface in front or below. The indifferent electrode should be held by the patient's hand, or it may be applied to the anterior abdominal wall. The strength of the galvanic current should be from 5 to 15 milliamperes.

### V. Genito-Urinary System.

#### STRICTURE OF THE MALE URETHRA.

Crussel, in 1839, was the first to employ electrolysis for the cure of stricture of the urethra; Mallez and Tripier were the first to practise it systematically.<sup>1</sup>

Dr. W. E. Stevenson<sup>2</sup> asserts that: The electrodes for this purpose are catheter-shaped gum-elastic bougies, terminating in a metal nickel-plated piece connected to a binding screw on the handle. Place the indifferent electrode on the patient's back; the metal plate is made

<sup>1</sup>"De la guérison durable des rétrécissements de l'urèthre par la galvanocaustique chimique," Paris, 1867.

<sup>2</sup>Annual Meeting of the British Medical Association, 1886.



positive. Estimate the distance of the stricture from the meatus, by marking on an ordinary bougie which has been passed. Suppose this bougie was a No. 3 (English). A No. 5 electrode is passed down to the stricture, where it is arrested. Corroborate this by previously marking the electrode, corresponding to the mark made on the bougie. Place the electrode again in position, connect it with the negative pole; the circuit is closed, and the current gradually increased without breaks, until the maximum strength is reached, about 5 or 6 milliamperes. The electrode is gently pressed against the stricture in the normal direction of the urethra until, from the dissolution of the obstacle in front of it, it passes into the bladder. The current should at once be cut off, and the bougie withdrawn.

The late Dr. Robert Newman, of New York City, advocated the following: The patient is placed in the dorsal position, the thorax, abdomen and lower extremities being in one horizontal line, while the head of the patient is slightly elevated by raising the head-rest of the table. A large electrode in the terminal, on the positive side of the battery, is placed over the abdomen in a fixed position, and well pressed upon the tissues, so as to make a perfect circuit.

The negative electrode, in the form of a whalebone bougie, has at the inner extremity an olive-shaped head of the proper size. This is introduced into the urethra as carefully as possible. The current is then turned on with the lever of the rheostat, so as to prevent shocking the patient.

The galvanic current that is used usually varies between three and five milliamperes. The treatments should last for a period of from 10 to 15 minutes. Two of these treatments are essential to start with, then discontinue for another period of two days or two weeks, according to the indication. Care should be exercised to pass through the lumen of the stricture a bougie of very little larger dimensions than that of the calibre of the opening. At the second treatment a bougie with a metallic ovoid should be passed, the dimensions of it being slightly larger than that used primarily. By doing this, there is a gradual dilatation of the lumen. After two weeks a bougie of little longer dimensions should be employed, and exactly the same process carried out as outlined above. The treatment should consume a little more time, and the current used should be 5 milliamperes. The third treatment should be given on the 16th day, the fourth on the 19th, and so on. The operator should always remember that in active inflammation of the urethral tract, electric applications are contraindicated.

After the dilatation of the stricture,<sup>1</sup> Selhorst inserts an Oberländer's urethroscopic tube, passing along the whole length of the

<sup>1</sup> British Med. Journal, March 24, 1906.



stricture. In examining the urethra, the tube is withdrawn slowly until the surface of the constriction is shown in the opening. The needle, ending in a strong platinum point from 1.5 cm. to 2 cm. in length, isolated quite close to its point, is forced to a depth of from 0.5 cm. to 1 cm. into the fibrous tissue, according to the dimension, thickness, and hardness of the stricture. The needle is the negative pole of a galvanic battery, the positive pole of which, a large moistened disk, is placed on the thigh or on the abdomen. The electric current, of from 4 to 6 milliamperes, is turned on for three minutes. Before withdrawing the needle Selhorst interrupts the current, and drives the needle into another part. This operation may be repeated four or five times during a sitting, and if executed by an expert hand, is said not to be very painful. During the whole period of treatment a bougie is introduced once weekly, followed by an irrigation with a nitrate of silver solution to promote reabsorption, and to maintain the passage of the urethra at the size required.

Philippe<sup>1</sup> credits electrolysis with many cures of simple stricture, but maintains that a combination therewith of lavage with carbonic acid is required when chronic urethral inflammation exists as a complication. He records excellent results in varicose ulcers, torpid wounds, fistula, etc. The gas is heated to 45° C. and driven into the urethra under a pressure that may be regulated. It is saturated with essence of cinnamon as an antiseptic agent. Minet and Aversenq use rigid bougies with a mercury bisulphate battery. A current of 3 to 4 milliamperes is passed for a period of 15 minutes, once weekly. This treatment is preceded by progressive dilatation with ordinary sounds, but the permanent results are mainly attributed to the electrolysis.

#### PROSTATITIS.

This condition may be treated with local faradization or galvanization. One of the poles is applied to the urethra or to the prostate through an insulated sound or catheter. The other electrode is in the form of an insulated rectal sound. The terminal of the electrode passed into the urethra is of course allowed to remain uncovered, as it is to come indirectly in contact with the prostate. The current should be of such a strength as to produce a sensation of warmth in the deep urethra.

Dr. John V. Shoemaker,<sup>2</sup> of Philadelphia, has devised an electrode which is well adapted to prostatic work. The instrument (Fig. 49) is for use in the reduction of hypertrophy of the prostate by means of the galvanic current from the negative pole. The usual flexible rheophores are

<sup>1</sup> La Presse Médicale, May 11, 1904.

<sup>2</sup> The Times-Register, January 17, 1891.

attached to the terminal binding posts (the negative pole of the battery being associated with the handle N, and the positive pole with the handle P). The reophores having been thus previously fastened, the rectal limb of the instrument (which has a movement in the vertical plane) is pressed down toward the sponge-covered moistened pole; the olive-shaped bulb pole, B, having been previously slightly oiled. The instrument is then, with the handle N held in the rear, passed under the crotch. The current of the battery is supposed to have been previously set flowing. Grasping then the rear handle, N, with the right hand, and allowing the front handle, P, to fall away from the crotch, the patient now presses the olive-shaped bulb, B, gently into the rectum; any slight error of judgment as to direction being compensated for by the movement of that limb in the vertical plane. The patient then grasps the front handle,



FIG. 49.—Shoemaker's prostatic electrolyzer.

P, and raises the lever formed by the hinges, H, thus bringing the moistened sponge-covered positive pole, S, in contact with the perineum. By exercising more or less pressure with this pole against the perineum, the current is then regulated to the greatest nicety by the patient's sensations.

The resistance to the current varies from 25,000 to 30,000 ohms, the milliamperemeter indicating from 2 to 3 milliamperes, the duration of administration being, according to Dr. Shoemaker and other authorities, from 3 to 5 minutes.

#### PARALYSIS OF THE URINARY BLADDER.

The electrical treatment for paralysis of the bladder is divided into the internal and the external. The currents employed are both the galvanic and faradic. Some suggest the use of the static current, but in my experience this has accomplished little good.

The external application is conducted by placing the negative pole or electrode over the symphysis pubis, and the positive to the back of the neck.

The internal application can be made by placing the insulated catheter electrode or Duchenne's double vesical electrode into the urethral tract. The negative pole of the battery is attached to the leader in the rubber catheter, while the positive pole is applied to the hypogastric region, or back of the spine.

#### INCONTINENCE OF URINE.

This condition is treated electrically, as in paralysis of the bladder. In the adult, both the internal and external methods may be employed. In children the external method alone is usually used.

Faradic treatment is to be preferred in cases of children and especially in those who have had incontinence from earliest infancy. Of 40 subjects, 55 per cent. were cured by Genonville and Compain;<sup>1</sup> 63 per cent. of the children were between 6 and 12 years old. The sittings numbered from 5 to 8 in congenital cases, and in non-congenital cases from 6 to 16 treatments, with the exception of 5 patients, who had 20 to 29 séances. Slight improvement during the first week is a favorable sign. The current may be applied directly to the sphincter or to that immediate region. All but 20 per cent. of the subjects were improved or cured, and in 16 cases a complete recovery occurred in a maximum of 16 visits.

*Nocturnal Incontinence.*—In this affection, the application of electricity stimulates the cerebral and spinal centres, by producing painful local impressions, which tend to bring the inhibitory cerebral mechanism into closer relation with the reflex centres in the lumbar cord. For women and older girls, a bare metal sound is introduced into the urethra as one electrode, the indifferent electrode being placed upon the lower dorsal spine. The sound must not enter the bladder for more than a short distance, or else the current will pass to the urethral walls. For male patients the applications can be made to the perineum.

#### SPERMATORRHŒA AND SEMINAL EMISSIONS.

These conditions can be treated either by the application of local or general galvanic or faradic currents, either internal or external. The internal method consists of introducing an electrode, insulated by a rubber catheter, into the urethral tract, as outlined in cases of prostatitis. In the treatment of vesiculitis or ordinary spermatorrhœa, care must be exercised to cause as little irritation internally as possible. The results

<sup>1</sup> La Presse Médicale, 1904, No. 38.



obtained are due to the electrolytic action on the mucous membrane, as a result of the mechanical pressure of the catheter, or upon a combination of these two factors. Sparks and the static breeze to the perineum, also the brush discharge over the lumbar and sacral vertebrae, may prove useful in some of these cases.

#### IMPOTENCE.

If this condition is the result of an organic lesion, electricity will do little good; on the other hand, benefit may be gained by the use of the static breeze, spark, etc. Cases of impotency due to a psychical influence may likewise be improved by the use of electricity.

#### ORCHITIS.

Scharff<sup>1</sup> employed electricity successfully in the treatment of epididymitis. During the acute stage he applies the anode to the lower part of the scrotum with the patient in the dorsal position, employing a large electrode with a maximum current of half a milliampere; duration of the first application three minutes; very gradually increased to five, and later to ten minutes. About the seventh day the current can be increased to three milliamperes. The cathode is placed over the groin and on the abdominal wall. The advantages of this treatment are its rapidity, and the early relief from pain and swelling. Good results have been obtained by Onimus and Duboc, of Rouen; <sup>2</sup> Picot, of Tours, has succeeded in forty cases.

#### NEPHRITIS.

Rockwell reports five cases of nephritis treated by electricity, four of which recovered. Treatment covered a period of from two to eighteen months; after a few months œdema and ascites disappeared.

The technic of treatment consists in the employment of a high-tension faradic current, and also the use of the static wave current, the latter being the more preferable. He suggests that these currents should be employed alternately.

### VI. The Nervous System.

#### NEURALGIA.

Electricity is applied to neuralgia in the following forms:

General faradization and central galvanization.

Local faradization or galvanization.

Central and peripheral, or a combination of both.

<sup>1</sup>Centralbl. f. Krankh. d. Harn und Sex. Organe, 1, 1894.

<sup>2</sup>Arch. d'Électricité médicale, 1894.



Galvanization of the cervical sympathetic.

Cataphoresis.

The sinusoidal current.

Electric brush.

Electric moxa.

Static electricity.

Electric bands and disks.

The magnet.

The initial applications should be mild, owing to the pain frequently becoming intensified, especially after prolonged sittings. The applications should be made daily, or every other day. Either the positive or negative pole may be applied over the painful points. There is no rule for the direction of the current. The duration of the séance should be brief.

Should the faradic current be tried without effect, resort should be made to the galvanic current, or the two may be used alternately. Central and general galvanization are to be conducted on general principles. Cataphoresis will at times benefit, when other methods fail. The sinusoidal current often acts most happily. The electric moxa is sometimes efficacious, but its use is attended with great pain. It acts partly as a counter-irritant.

*Cephalalgia*.—Dry faradization with the hand is most useful in many forms of headache. Stable galvanization or faradization, uniform or increasing, may be used. General faradization is more effective than local applications. Central galvanization is at times the only effective measure.

*Tic Douloureux*.—In this exquisitely painful condition, peripheral galvanization or faradization should be tried; the electric moxa, or galvanization of the brain or cervical sympathetic, has in some cases proved effective.

Professor S. Leduc, of Nantes,<sup>1</sup> reported several cases in which he had obtained excellent results in neuralgia by the electrolytic introduction of salicylic ions (galvanic cataphoresis). Recently he has again resorted to this method with success in a case of tic douloureux of thirty-five years' standing. This patient was cured, according to Dr. Leduc, in three séances by salicylic ionization. The method followed was to apply the cathode, moistened with a solution of sodium salicylate, to the right side of the face, and at the first treatment the current was raised gradually to an intensity of 45 milliamperes and maintained there for forty minutes. After the second séance, which took place three days later (when the current was allowed to pass for one hour, with a current of 35 milliamperes), he experienced decided ameliora-

<sup>1</sup> La Semaine Médicale, November 22, 1905.

tion. Finally, a third and last ionization, of forty minutes, brought about a final cessation of the pain. The pain now only returns during exposure to cold.

*Peripheral Neuralgia.*—Whatever the cause, these cases should be treated by stable faradization and galvanization, or the electric moxa. In rebellious cases, central and general electrization should be tried.

*Sciatica.*—Faradization is to be recommended in this condition. For the novice, galvanization is to be preferred, owing to the extreme evenness of the current required. An ill-directed, prolonged current often aggravates the condition. I have had good results with the static spark.

#### PARALYSIS.

*Rheumatic Paralysis.*—In these cases faradization is extremely useful. The electro-muscular contractility in recent cases is normal, in long-standing cases diminished. It is important to institute treatment before the occurrence of muscular atrophy. Static and galvanic electricity are also valuable in rheumatic paralysis.

*Syphilitic paralysis* is treated in a manner similar to rheumatic paralysis.

*Lead Paralysis.*—In this affection the electro-muscular sensibility is diminished and frequently lost, and diplegic contractions may appear. If the electro-muscular contractility is completely lost, apply a galvanic current, 5 to 15 ma., to the paralyzed part before the faradic current is employed. The latter current should be used daily, 10 to 15 minutes at each sitting. When the slightest contractions occur from the faradic current, the galvanic may be discontinued.

*Paralysis from opium, stramonium, arsenic, etc.,* is to be treated by general faradization.

*Hemiplegia.*—Treatment should not be commenced until four or five weeks after the attack. Vigorous electrization of the affected limbs may completely restore them. Further efforts may be directed to the cranial lesion by the application of the continuous current. The anode is applied to the forehead and to the sides of the head, the cathode to the nape of the neck; the former electrode being moved slowly to and fro without interruptions. Current strength 1 to 5 ma. The active electrode should be of medium size. Daily treatments for one month; duration of each sitting, 5 minutes. If aphasia be associated, the anode may be applied to the third left frontal convolution. I prefer the static breeze over the head, with indirect sparks to the affected side.

*Paraplegia.*—Early in the disease the galvanic and the faradic reactions may be normal. Where the posterior columns are affected, electro-æsthesia may likewise coexist. Treatment consists in galvanization or

faradization. The electro-muscular contractility is frequently so much diminished that it becomes necessary to give particular attention to the motor points in order to produce contractions.

*Facial Paralysis.*—Facial paralysis should be treated by local faradization and galvanization. When response is not obtained by the faradic current, it is of little use to employ it; it being far better to depend upon the galvanic current. In this disease the current-reverser electrode is exceedingly convenient. A current just sufficient to produce contraction is better than a stronger current, and short applications are preferable to long ones.

*Poliomyelitis.*—In poliomyelitis, the paralysis precedes the wasting. The faradic irritability soon becomes lost, with temporary increase of galvanic irritability and degenerative reactions. The latter are often mixed, due to the nerve-fibres being unequally affected, an increase of galvanic irritability in the muscles with retention of faradic irritability in the nerve. In infantile palsy, there is loss or absence of electro-muscular contractility. Treatment consists in the galvanization and faradization of the affected muscles, and the constitutional methods of treatment of general faradization, central galvanization, and static electrification.

*Locomotor Ataxia.*—The electro-muscular contractility may be normal or increased, as distinguished from ordinary motor paralysis, depending upon anterior or lateral spinal sclerosis. It may, however, be diminished. The disease may be treated by galvanization of the spine, central galvanization, and general faradization, when cerebral disturbances or general ataxia of the nervous system appear, galvanization of the cervical sympathetic and peripheral faradization with sponges and the metallic brush. Static electricity by means of long percussive sparks over the spine is often useful.

#### CHRONIC SPINAL MUSCULAR ATROPHY.

The use of central galvanization is here indicated, with faradization and galvanization of the affected muscles. Static electricity is strongly commended by many electro-therapeutists.

#### EPILEPSY.

Erb recommends the following method: "Place the anode over the forehead, and the cathode to the neck. Current 1 to  $2\frac{1}{2}$  milliamperes. The duration of each treatment is about one minute. The position of the electrode is then changed; the anode is then placed to the middle line of the head and the cathode to the occiput."

I advise the administration of the static current; especially the wave current or breeze over the head, has in some cases done good. The current should be applied every day, if possible, and continued for months.



## INSOMNIA.

This affection frequently yields to treatment by electricity. I have seen patients fall into sleep while I was treating them with the static breeze. The galvanic current applied to the sympathetic system, or the faradic current applied to the head and spine, and also general faradization have given most encouraging results. The majority of electrotherapists incline to the opinion that the most favorable results are attained by employing the static current.

## HYSTERIA.

In this condition a psychical effect is produced by the static and also by the galvanic current. It is also possible in many cases that a lessening of nervous irritability results from the electrical applications. In fact very little, if any, good is done in this disease by the use of electricity.

## HYPOCHONDRIASIS AND MELANCHOLIA.

In these conditions both general galvanization and faradization of the cervical sympathetic do good by the psychical effect upon the patient. Static electricity in some cases would appear to be beneficial.

## INSANITY.

The various forms of insanity are at times favorably influenced by using the same treatments as are referred to in the preceding paragraph. It is unfortunate that in asylums electricity has not been more extensively employed. The use of the static bath would seem to be beneficial, and to this end experiments are being conducted at the Philadelphia Hospital.

## NEURASTHENIA.

Dr. Charles K. Mills<sup>1</sup> believes that electricity used only in the form of general faradization, with a slowly interrupted current, is less useful than massage. In not a few cases, the nurse who attempts to give faradic electricity to a patient is unskilful or irritating in her method of administration. On the whole, Mills prefers the method of direct muscular faradization, supplemented with gliding or labile currents, applied to the entire limb or part. The nurse holds two moistened electrodes in one hand, and passes from one muscle to another; then placing one electrode to the spine or in the neighborhood of the nerve plexus, the electrode is passed from point to point down the limb.

<sup>1</sup>Transactions of the Philadelphia County Medical Society, Nov. 29, 1905.



Dr. W. B. Snow<sup>1</sup> says in reference to the electrical treatment of neurasthenia: "For the general tonic effects indicated in every case of neurasthenia, the wave current should be administered, by placing the long, spinal electrode (one inch in width and 18 to 22 inches in length) over the vertebral column from the cervical to the lumbar region for from at least 15 to 20 minutes, and employing as long a spark-gap as may be used without causing uncomfortable muscular contractions.

"Patients will usually take a treatment with a four-inch spark. Though persons with small muscles and but little fat may not bear a two-inch spark-gap current, large or fat persons will bear and require one measured by a five- or six-inch spark discharge. After the first few applications, the patient perspires gently with each such treatment. Not only does the activity of sweat glands resume, but there is a gradually increasing resumption of other functions. There is marked increase in the daily excretion of solids in the urine, digestion improves, appetite returns, the bowels become more regular.

"While many cases have been cured by no other agency than the wave current, we believe that the active peripheral stimulation and massage afforded by the long and friction sparks hasten the recovery of every case, the time factor of which will depend on the duration of the affection, the adherence to regimen, the extent of functional derangement, the recuperative powers of the patient, the regularity with which the treatments are administered, and the technic employed. Treatment should be given daily for at least two weeks, when every second day may suffice."

#### EXOPHTHALMIC GOITRE.

In the treatment of exophthalmic goitre, Dr. Francis B. Bishop,<sup>2</sup> of Washington, believes that the only rational method of procedure is by means of the electric current.

The vagus is easily stimulated in the neck from the subauricular fossa to the clavicle, and with a much weaker stimulus and in much less time than the sympathetic. So with care we may get the inhibitory and other influences of the vagus, without unduly exciting the sympathetic.

Preference for the application to the vagus, has been for the continuous current, and the method of application has been to stimulate both nerves at the same time. A large sponge-electrode, attached to the positive pole, is placed high up on the back of the neck. A bifurcated cord is used for the negative side, and two small sponge-electrodes are placed one on each side over the pneumogastric, in the lower part of the neck and impinging upon the thyroid.

<sup>1</sup> Post-Graduate, December, 1900.

<sup>2</sup> The Journal of Advanced Therapeutics, February, 1904.

“The current is gradually turned on and the pulse noted,” says Bishop; “the current is allowed to remain at that point for ten or fifteen minutes, or longer, until a decidedly quieting effect has been produced. Then the small sponges are placed directly on the gland and the current turned on to the point of tolerance, and is allowed to pass from five to eight minutes. This treatment is persisted in every other day, and in many cases a decided improvement will be noticed in a month. Later, I have been using the high-potential, high-frequency current as an auxiliary, and have been much pleased. One patient begged me to discontinue all other treatment, as she was so much benefited by the high-frequency spark applied directly to the thyroid and cervical spine, over the liver, spleen, kidneys, abdomen, and over the region of the ovaries. A letter received some time ago states that she continues to improve.”

Heüman's<sup>1</sup> experiences with electro-chemical treatment of exophthalmic goitre encourage further work in this line, he thinks. He applies the cathode over the goitre with the continuous current, 25 to 40 milliamperes, similar to Bordier's technique, except that he uses a cathode which contains potassium iodide. In one case, for instance, he applied a current of 20 milliamperes for about twenty minutes a day, the positive electrode on the back, and the negative on the neck. The cathode was placed on a thin sheet of lead, shaped to the neck, over several layers of sterile gauze impregnated with a concentrated solution of potassium iodide, covering the entire goitre. The current was turned on and off very gradually. After a week of this treatment all the symptoms of the exophthalmic goitre had disappeared, and the size of the neck had been reduced from 39.5 cm. to 38 cm. The patient felt perfectly well and has continued in good health since that time—November, 1905. The improvement in another case described was almost equally striking, and in this case iodide was found in the urine five days after the last application. He also detected iodine in gauze under the anode of the back. Other cases from his experience are described and some of the laws of electro-chemistry are cited to explain the phenomena observed.

## VII. Gynecology.

The value of electro-therapeutic measures in gynecology has been for many years a subject of heated discussion among its many champions, and among the equally numerous opponents to its employment in diseases peculiar to women.

Dr. Barton Cook Hirst,<sup>2</sup> of Philadelphia, remarks that of late he has found galvanism and faradism of value in a limited number of

<sup>1</sup> Hygieia, Stockholm, Last Index, p. 903.

<sup>2</sup> “Limitations and Possibilities in the Treatment of Diseases of Women,” read before the Philadelphia County Medical Society, January 25, 1905.

conditions in gynecological practice. As a hæmostatic in uncomplicated small fibroid tumors, with no other symptom than metrorrhagia, he regarded it as a most efficient agent. He found it peculiarly useful in the treatment of amenorrhœa and sterility, the results of imperfect development or atrophy of the uterus. Two illustrative cases were reported in which normal menstruation was restored and conception occurred after the use of this treatment. In one woman there had been amenorrhœa for a year. In the other, the menstruation had been reduced to a scanty discharge lasting less than a day, as a result of lactation atrophy. The third indication was to restore tone to a parietic sphincter ani muscle, after its imperfect restoration by surgical means, in which there had been no contractile power exercised for a number of years. A



FIG. 50. Vesical electrode, for hydro-electric application to female bladder. Useful in atony, dilatation, chronic cystitis, etc.

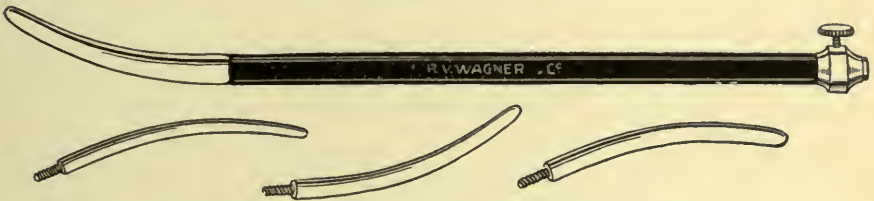

FIG. 51.—Goelet's intra-uterine electrode, with interchangeable tips.

fourth indication was found in certain types of dysmenorrhœa associated with an ill-developed uterus. Local treatment, however, he believed, was very rarely practicable in such cases.

In disease of the uterus, local, central, and general treatment may be employed. Local treatment may be external or internal.

The uterus and the appendages may be treated electrically by applying one pole over the hypogastrium and the other over the lumbar region. In virgins this method should always be tried first.

In the internal method, one pole may be applied to the os by means of an insulated electrode with a metallic belt, while the other, bearing a broad electrode, is applied to the back, or on the hypogastric region, or over an ovary.

In using the faradic current, both poles are applied internally. The sinusoidal current is of great value for the alleviation of uterine pain. Figs. 50 and 51 illustrate two valuable electrodes in gynecological work.



## AMENORRŒEA.

For amenorrhœa Dr. Golding Bird<sup>1</sup> believes in the value of shocks from the Leyden jar. He transmits twelve successive shocks, from the sacrum to the pubes. Panecki uses the induction coil. In chlorosis, marked benefit is said to accrue from the nutritional effects of the electric bath. In healthy women who menstruate regularly, electricity often hastens the flow, especially when applied to the abdomen or pelvic region. Another method consists in having the patient lie on a large electrode, and in applying a circular one with the handle alternately to the epigastrium and hypogastrium, *stabile*, using 30 milliamperes. This should be succeeded by a strong primary faradic current.

## DYSMENORRŒEA.

When this affection is due to a cervical stenosis, electrolysis is indicated. For dysmenorrhœa, independent of stenosis or structural change, the galvanic current is of value in relieving congestion and pain. The applications are to be made prior to menstruation and repeated daily. These same applications offer most beneficial results in dysmenorrhœa dependent upon pelvic cellulitis; occasionally the faradic current is of value.

## FIBROID TUMORS.

The electrical treatment of uterine fibromata has been elaborately studied by Bartholow, Massey, Engelmann, and many others. Indeed since the brilliant investigations by Apostoli, the literature of uterine fibromata has assumed massive proportions. In 1882 Apostoli, in an article to the Académie de Médecine, expounded his views on a subject heretofore unthought of, that at once aroused attention and invited thought. He advised the use of an internal platinum positive electrode, and an abdominal negative electrode, of large surface, made of moist china clay, with a continuous current of 60 to 70 milliamperes. Applications 5 to 15 minutes. Séances once or twice weekly. The current was to destroy the mucous membrane, which was succeeded by a healthy repair process and by a cicatrization to check the metrorrhagia.

Bergonié and Boursier<sup>2</sup> sum up the results they obtained in one hundred cases of uterine fibroids as follows: "The electric treatment of fibro-myomata is undoubtedly efficacious as a palliative method of treatment. When hemorrhage was the chief symptom complained of, 90 per cent. were relieved. The general state of health was improved in 79 per cent.; the pain was relieved in 50 per cent., while a decrease in the size of the tumor was observed in 10 per cent. only."

<sup>1</sup> Electricity and Magnetism, 1849, Lecture V, and Appendix B.

<sup>2</sup> Arch. d'Électricité médicale, 1893, 211.



## OVARIAN TUMORS.

The electrolytic treatment of these tumors, which was formerly so largely in vogue, has been completely abandoned by electro-therapeutists. The danger incident upon operation is less than that incurred by electrolytic means.

## CHRONIC METRITIS.

In these cases either the faradic or galvanic current may be used. The more usual method is to apply the galvanic current. Place the anode (per speculum) upon the os, and the cathode upon the epigastrium, stable 5 to 10 minutes, 2 or 3 times a week. Current about 20 milliamperes.

## PERIUTERINE HÆMATOCELE.

Apostoli's method is intended to effect a chemical caustic change by means of the cathode. A fistula is thus established, which tends to remain open, with adhesions between the seat of the affection and the external mucous membrane.

## STENOSIS OF THE CERVICAL CANAL.

In these cases galvanism is of great value. Introduce a sound, connect it with the cathode, apply the anode to the abdomen. Current 50 to 75 milliamperes; application 5 minutes.

## SUBINVOLUTION AND ATROPHY.

Early in the condition, the faradic current is most useful, applied by means of the bipolar electrode. Later in the affection the galvanic current is to be employed, and the treatment to be instituted is similar to that for chronic metritis.

## URETHRAL CARUNCLE.

If pedunculated the galvano-cautery snare is passed around the caruncle and the current turned on. The carbon or platinum electrode is used, covered with absorbent cotton saturated in a solution of cocaine. Current 5 to 15 milliamperes. When no pedicle exists, puncture with a negative needle; current 10 to 15 milliamperes.

## POST-PARTUM HEMORRHAGE.

Use current of the primary wire with an inter-uterine electrode, with the indifferent electrode on the abdomen. A pocket faradic battery answers admirably, that of Gaiffe of Paris being deservedly popular.

## VOMITING OF PREGNANCY.

In vomiting of pregnancy the induction coil of fine wire is preferably employed. Apply the anode to the nape of the neck, the cathode to the epigastrium. Avoid the uterine region.

## SLOW LABOR.

This may be hastened, and atony and inertia of the uterus overcome by the use of the faradic current. Electrodes of large size are applied on each side of the fundus, near the umbilicus. A powerful current is passed with the occurrence of a pain.

Dr. C. A. Covell, in a paper entitled "A Case of Asthma with Fibroids and Pelvic Adhesions Cured by Galvanism,"<sup>1</sup> mentions the case of a patient, aged 37, married, who suffered with marked dysmenorrhœa and bearing-down pains. The pelvic trouble became constant, and she was advised to undergo an operation for hysterectomy and ovariectomy. The author then says, "because of the great tenderness and pain I used the vaginal abdominal alternations, a large pad of absorbent cotton and wire being placed over the abdomen and a Leclanché zinc insulated with rubber tubing, the tip covered by cotton, was placed in the vagina. Gradually turning the current on and off, and reversing it occasionally, from 25 to 100 milliamperes were used, she being able to bear more current some days than at others. Treatments were given at first every other day and later twice a week only. Improvement was rapid. In six months the exudate was absorbed, and in one year the pelvic organs were nearly normal. The fibroids were reduced to the size of a walnut. The pain ceased, and as the pelvis cleared the asthma became less and less, finally ceasing also.

"I did not see her again professionally for four years. One year since she became pregnant, without any unusual symptoms. She went to full term, and in May last was delivered at the Good Shepherd Hospital of a nine-pound boy. Labor lasted five hours and was normal in all respects. While she was under chloroform I carefully examined the uterus and found two interstitial fibroids the size of my thumb.

"To me the interesting things about this case are these: The asthma was of reflex origin and ceased as the pelvic condition was relieved.

"The method of application of the current in perinterine inflammation.

"The uterus, which the leading gynecologist of central New York said it was necessary to remove to save the patient's life, under electrical treatment produced four years later a healthy child."

<sup>1</sup>Read at the Thirteenth Annual Meeting of the American Electro-Therapeutic Association, Atlantic City, September 23, 1903.

### VIII. Aneurism.

Treatment of aneurism by electro-puncture dates back to Pravaz (1838), Peterkin (1845), and Ciniselli (1870).

Ciniselli<sup>1</sup> has collected 23 cases of aneurism, six of which were apparently cured by electro-puncture, 16 died, and in one case result is not known. The operators sometimes used one needle in the sac, sometimes both. Tripier advocates the insertion of the positive needle only, on account of its property of coagulating albumen. In Ciniselli's cases, 20 to 40 cells were used from 10 to 30 minutes. The method now frequently employed is to take a fine coiled wire of gold, silver, or platinum, so drawn out that it may be readily passed through a thoroughly insulated needle. The anode is the active electrode, the cathode, a clay pad on the abdomen. The current may gradually ascend to 80 milliamperes. Duration 30 to 60 minutes.

Cornelius A. Griffith<sup>2</sup> describes an interesting case of sacculated aneurism of the abdominal aorta, treated by the introduction of silver wire and the passage of the constant current.

The tumor was in the epigastrie region, lying almost directly to the left of the middle line, extending up under the ribs and downward nearly to the umbilicus, its size being about that of a cocoanut; it caused some bulging of the epigastrium, was distinctly pulsating, and presented a well-marked systolic bruit. Pain was constantly present in the back and at the left side, and also in the epigastrium, following the taking of food; occasional retching was experienced, but there was no actual vomiting.

Subsequently an operation was determined upon, when a fine, long, metal trocar and canula were thrust well into the sac, the trocar was withdrawn, and a vulcanite insulating canula substituted, through which fine silver wire was introduced into the sac. About six feet of wire were passed in, connected to the negative pole of a constant current battery, and 15 to 25 milliamperes passed for 15 minutes. At the end of this time it was noticed that the tumor was harder and the pulsations had grown less. The canula was then withdrawn and the operation completed, whereupon it was noticed that the bulging caused by the tumor had almost disappeared. Patient died in about five hours, apparently from shock. Post-mortem examination showed that the sac was filled with a dark clot about the coiled wire, and that a double loop of the wire had been passed for about two inches up into the thoracic aorta. The introduction of coils of wire in aneurismal sacs

<sup>1</sup>Luigi Ciniselli ("Sugli aneurismi dell' aorta toracica finora trattati colla elettropuntura"), Milliano, 1870, quoted in Dr. Keyes's paper on "Practical Electro-Therapeutics," New York Med. Journal, Dec. 1871.

<sup>2</sup>London Lancet, August 12, 1905.



should be avoided if possible, and the immediate clotting of the blood within the sac by the passage of a small current is believed to be of advantage.

Dr. H. A. Hare<sup>1</sup> reported eight operations of this nature, the three now reported, making a total of eleven, in his own experience.

The first of these three cases occurred in a woman of 50, the aneurism involving the superior and posterior portions of the transverse arch of the aorta, and included the origin of the large vessels arising from this part of the aorta. The occurrence of severe symptoms made relief imperative, and gold wire to the amount of eight feet was passed into the sac through an ordinary insulated needle, and through this wire was passed an electrical current started at 5 milliamperes and gradually increased to 50 milliamperes for 30 minutes. The immediate effect of the operation was to relieve the pressure symptoms, and for several weeks afterward she was able to sleep in a reclining posture with perfect comfort. Six months later the growth began to enlarge at the margin of the clot, and death finally occurred from pressure and exhaustion. Autopsy confirmed the diagnosis in every particular, and revealed the wire embedded in the clot.

The second case occurred in a man aged 42, and was probably traceable to heavy lifting. There was some paralysis of the right vocal cord, but no interference with swallowing; the growth filled the epiclavicular space at the right side, and passed backward under the sterno-mastoid muscle, pushing apart the bellies of the two branches of this muscle and protruding prominently into this space. Two feet of gold wire were passed into the tumor and the current passed as before, from 5 to 50 milliamperes being used in the course of 40 minutes. The patient was relieved immediately after the operation, and his voice, to some extent, soon returned. Four months later, however, he died from exhaustion and pressure. Autopsy confirmed the diagnosis, but, strangely enough, no trace of the wire could be found in any part of the clot.

The third case occurred in a woman aged 50, and involved the thoracic aorta just below its descending portion. Erosion of the ribs was noted upon the left side, so that the sac projected to the extent of two inches outside of the line of the body between the vertebræ and the lower third of the left scapula. Nine feet of wire were introduced and the current passed as in the preceding case, from 5 to 50 ma. during a period of three-quarters of an hour. The immediate effect of the operation was to diminish the expansile pulsation. At the end of four months, however, the patient died from pressure symptoms and exhaustion. The autopsy confirmed the diagnosis and revealed the wire embedded in the centre of the clot.

<sup>1</sup>Therapeutic Gazette, July 25, 1905.





FIG. 52.—Ozone inhalation. The generator should be suspended to within a few inches from the mouth of the patient, and attached to the positive pole of the machine. The patient is placed upon an insulated platform connected with the negative pole. The oxygen of the air confined within the globe is broken up, forming ozone, by the convective discharge of the current passing from the numerous points of the brush within. It is of paramount value where sprays or medicated vapors cannot reach the part by other means.



## CHAPTER IX

### APPLICATIONS IN THE SPECIALTIES.

#### I. Rhinology and Laryngology.

##### ATROPHIC RHINITIS.

IN atrophic rhinitis, Delavan<sup>1</sup> suggests the application of the negative pole to the retro-nasal space, and the positive pole to the nape of the neck. The strength of the galvanic or faradic current should be from 4 to 6 milliamperes. Each treatment should last from 5 to 12 minutes. The applications should be made every other day.

##### PHARYNGITIS.

Hahn<sup>2</sup> asserts that he obtained good results in cases of pharyngitis by the use of the faradic current. Violet rays and high-frequency currents have frequently proved useful. In pharyngitis, and in many pharyngeal and laryngeal affections, ozone inhalations have been warmly commended (Fig. 52). Many ingenious electrodes for nasal and pharyngeal work have been devised, two very useful ones being shown in Figs. 53 and 54.



FIG. 53.—Curved sponge electrode for application to throat.



FIG. 54.—Electrode for hydro-electric applications, post-nasal and pharyngeal.

##### OZENA.

In this affection some electro-therapeutists apply cupric electrolysis. In 1895 at a meeting of the Belgian laryngologists and otologists, Cheval

<sup>1</sup>Transactions of the American Laryngological Association, 1887, p. 146.

<sup>2</sup>Journal de Médecine, Paris, November, 1902.

announced the cure of 91 per cent. of cases of ozæna at a single séance. He employs a copper needle (positive pole) and inserts it into the mucous membrane of the middle turbinated bone, and introduces a steel needle into the mucous membrane of the inferior turbinated bone of the same side. The strength of current is between 18 and 20 milliamperes, for a period of 10 minutes.

#### ANÆSTHESIA OF THE PHARYNX.

Induced or continuous currents, percutaneous or pharyngeal, may be used in such cases. Short static sparks are often beneficial.

#### LARYNGEAL FATIGUE (*fatigue vocale*).

Bordier<sup>1</sup> states that Moutier and Granier of the Opera in Paris, had been able to prove that electro-static applications exerted a favorable influence upon laryngeal fatigue. The patient was charged negatively and the anode or grounded point electrode was applied near the mouth and nose. Applications daily for 15 or 20 minutes showed an increased duration of the respiratory movements, the pitch of the laryngeal sound was raised, and the quality of the voice became more agreeable.

#### ATROPHIC PHARYNGITIS.

Shurley<sup>2</sup> used cocaine in the treatment of atrophic pharyngitis and then applied one electrode through the nose, and the other to the posterior and lateral wall of the pharynx. The current increased both the color and secretion of the membrane. With the use of the faradic current, Sajous has obtained good results.

#### ANOSMIA.

Anosmia may result from long continued rhinitis or from a peripheral lesion.

The treatment may be external and internal. The external treatment is the same as for rhinitis, save that the current is stronger. The internal treatment consists in the direct application of a metallic electrode to the nasal mucous membrane.

Rockwell mentions a case of anosmia<sup>3</sup> of six years' duration, where the patient could only perceive the odor of kerosene oil and freshly ground coffee, and who was entirely cured by two applications of the faradic current.

<sup>1</sup> "Medical Electricity," by H. Lewis Jones.

<sup>2</sup> Transactions of the American Laryngological Association, 1887, p. 146.

<sup>3</sup> Medical and Surgical Electricity, by A. D. Rockwell, p. 482.



## ASTHMA.

The galvanic current over the pneumogastric and sympathetic regions has been frequently used in asthma, with asserted good results. The faradic current is sometimes effective. In some instances persistent faradization of the chest and neck has been followed by marked relief.

Courtade, in a communication made to the Société Médico-Chirurgicale,<sup>1</sup> recommended the application of electricity to the lateral cervical region. The positive pole is placed on the neck, so as to produce a condition of electrotonus,—*i. e.*, a diminution of the excitability of the nerve. Thus directed the current acts upon the pneumogastric at first in a centrifugal manner, so as to excite the bronchial and laryngeal muscles; following this it acts centripetally upon the phrenic nerve, and upon the great sympathetic. The excitation of the latter is able to modify the vaso-motor activity of the vessels of the medulla oblongata and the respiratory centres. The results were found to be very favorable in essential asthma.

## II. Otology.

## AUDITORY-NERVE DEAFNESS.

This is best treated by the bifurcated electrode and the battery current, using the cathode to the ears. Gradually vary the current by employing a rhythmic interrupter, or by turning the current on and off with the current collector. Ten milliamperes is the maximum. Séances of 5 or 6 minutes are long enough. Apply to both ears simultaneously, so as to prevent vertigo. Use electrodes of a one-inch surface. Place a small pad of moist absorbent wool between the electrode and the skin, because, the electrode being small, the density of the current is great. One variety of the double ear electrode is shown in Fig. 55.



FIG. 55.—Double sponge-tipped ear electrode insulated with hard rubber.

## CHRONIC SUPPURATION OF THE MIDDLE EAR.

Rockwell states that in experimenting on these cases he used the galvanic current. The theory on which the experiments were based was that ulcerous conditions in the ear might be treated electrically, similarly to the same conditions elsewhere. An electrode with a long, narrow extremity, covered with a little cotton, was inserted into the auditory

<sup>1</sup> Le Bulletin Médicale, February 21, 1906.

canal through a rubber speculum, the canal being filled with tepid water. The electrode is usually connected with the negative pole of the galvanic current, though sometimes with the positive. The circuit is completed by the hand of the patient holding a sponge electrode, or resting on a stationary electrode. Weak currents and short applications are to be employed, while some form of rheostat is indispensable.

#### TINNITUS AURIUM.

Subjective noises can sometimes be dispelled at once by battery currents.

In chronic ear disease, when patients are electrically treated, the tinnitus is often found associated with great increase in the irritability of the auditory nerve.

In treating tinnitus aurium select two small, well-padded electrodes, of about 2 cm. in diameter, to form a divided anode; apply one to each ear, just in front of the tragus. The cathode (an electrode of large size) is applied to the nape of the neck. The current is slowly raised to 5 milliamperes. Duration 10 minutes. The anode usually diminishes the tinnitus, the cathode increases it; sometimes the reverse occurs. If no improvement follow either application, it is futile to continue.

Dr. William S. Bryant<sup>1</sup> details excellent results obtained from electrical treatment in tubal tinnitus wherein other methods had failed. The negative pole can be applied to the tube, preferably through the nose. It is best made in the form of an eustachian catheter, conical at the tip, and in three sizes. It should be insulated to within three-quarters of an inch of the end of the electrode. Duell's electric bougie is very satisfactory in the most refractory cases. Atrophy calls for stimulation and electricity.

As a complete *résumé* of the uses of electricity in aural diseases and affections, I can do no better than append the following abstract from the excellent paper of Dr. J. J. Richardson, of Washington, D. C., entitled "Electricity in Otology."<sup>2</sup>

" \* \* \* \* I am not an enthusiast, who claims electricity to be a panacea for all diseases, but after careful experimentation and observation, I am convinced that it at least possesses great possibilities along certain lines. \* \* \* \* I know from practical experience that we can by its employment in one form or another (1) stimulate weak muscles, (2) relieve pain, either by direct action of the current or by the cathartic application of anaesthetics, (3) stimulate absorption of inflammatory exudates, (4) overcome stenosis or complete strictures, and (5) at times revive nervous activity. A thorough knowledge of the physiology

<sup>1</sup>Laryngoscope, July, 1904.

<sup>2</sup>New York Medical Journal, February 25, 1905.

and pathology of the parts we are treating and also of electro-physiology and electro-physics is demanded. The apparatus must be of the highest standard and under perfect control, as otherwise we are assuming a risk which is unjustifiable, and may inflict injury instead of affording relief. For example, in the application of galvanism, the polarity of the current is of the greatest importance. The negative pole will often do good whilst the application of the positive may be painful and even injurious. \* \* \* \* Again, a mild current will frequently relieve or cure conditions where a stronger one would aggravate them.

“ \* \* \* \* There are different methods of applying electricity to the ears. The one which I employ for both the galvanic and faradic currents, when both ears are to be acted upon, is a bifurcated intra-auricular electrode, the metallic ends of which I cover with moist absorbent cotton. For the indifferent pole, an ordinary sponge electrode is placed in the hand or over the nape of the neck. I frequently apply it to the eustachian tube by introducing a hard-rubber catheter in the ordinary way, and passing through it a metallic bougie electrode, applying the other electrode over the mastoid region. In this way it acts directly on the muscles of the tube, which at times lose their normal tonicity, and it also stimulates the circulation of the parts. For this purpose I usually employ the faradic current, which produces a sort of tingling sensation, but no vertigo or other symptoms of cerebral irritation.

“The active pole for therapeutic purposes should most always be the positive, unless electric torpor exists, as it is the sedative, decongestive one. The negative pole, which we employ in studying the auditory nerve excitability, acts in the inverse sense; with the faradic current the polarity is unimportant.

“In the distressing symptom of tinnitus, electricity will frequently be beneficial where other forms of treatment have been of no avail. It is in these cases where the ordinary treatment of inflation, eustachian and middle ear medication have been instituted, and where the naso-pharynx and nasal cavities have been treated with negative results, that electricity offers some encouragement. A fair percentage of the patients will be greatly benefited, and one occasionally cured. When the tinnitus is of labyrinthine origin, or due to chronic inflammatory changes in the middle ear, the constant current is the one mostly employed. One to three milliamperes are sufficient and should be allowed to pass from 6 to 10 minutes. Where there is ankylosis of the ossicles, the interrupted current has been more satisfactory in cases, although less frequently employed than the constant current. The good effects are to be found in its mechanical action on the adhesions, and to its stimulating action on the circulation, and also upon the weakened muscles of the middle ear.



“True strictures of the eustachian tube are rare, and are best treated by electrolysis. The galvanic current is utilized for this purpose. A hard-rubber or silver catheter, properly insulated with rubber up to its point, is introduced, and a small gold bougie is passed through the catheter and up to the point of constriction in the tube; the bougie is the active electrode. It is to be attached to the negative pole of the battery, the current turned on slowly, and 3 to 6 milliamperes are to be allowed to pass. After 6 or 8 minutes, by a gentle pressure on the bougie, it will be felt to pass the softened stricture. The operation is a little painful, and for a few days following there will be an increased amount of deafness and ringing and fulness in the ear. On the third day usually a celluloid bougie is to be passed and at the same intervals of 3 or 4 days for 2 or 3 weeks. The dispensing electrode is held in the hand in preference to the mastoid region, or over the neck, where there will be less tendency to cerebral irritation.

“Complete success, by electrical treatment, for deafness either of tympanic or labyrinthine origin, is of rare occurrence. I do not recall any cases that I have treated where the hearing was greatly improved, except those naturally resulting from the diminution of the subjective noises. Hysterical deafness, like hysterical aphonia, is best treated by the faradic current. Pruritus of the auricular canal is often benefited by this form of treatment. In neuralgic otalgia the interrupted current is very efficacious when applied by means of an intra-auricular electrode. The incomplete anæsthetic effect of cocaine may be aided by the action of the constant current. This cataphoric process is utilized in producing anæsthesia of the tympanic membrane and external canal for slight operative procedures. The auricular canal is filled with a 10 per cent. solution of cocaine and a mild current allowed to pass for 5 to 10 minutes, when anæsthesia ensues. This same process has been utilized by some with various drugs as a means of curing deafness, but I have had no personal experience along these lines, and the results published are not encouraging. The positive pole should be in contact with the fluid, and the negative pole applied over the neck.”

### III. Ophthalmology.

#### PARALYSIS OF THE MUSCLES OF THE EYE.

This may be cerebral or peripheral in character. For this paralysis, galvanic currents are preferable. When the condition is thought to be cerebral in origin, galvanization of the sympathetic should be resorted to. Treatments of a half-minute duration are to be employed.

#### BLEPHAROSPASM.

Galvanization or faradization is here indicated, for the same reason that it is indicated in torticollis. Ptosis is to be treated in a similar manner.



## CATARACT.

The Russian observer Crussel<sup>1</sup> claimed to have obtained perfect success in cases of cataract by the galvanic current. His method was to introduce a needle into the lens, which was connected with the negative pole, while the positive was applied to the tongue; in this way, the cataract was subjected to mechanical disintegration by the needle, to the chemical influence of the negative pole, and probably also to the macerating action of the aqueous humor penetrating the lens, through the puncture made in the capsule by the needle.

## ELECTROLYSIS IN DISEASES OF THE LACRYMAL CANAL.

Lotine<sup>2</sup> reports a number of cases of disease of the lacrymal passages in which he successfully employed electrolysis applied by electrolytic probes, which were insulated along the greater part of their length by a coating of the same material as that used to cover elastic bougies. The particular portion of the probes so insulated could thus remain in the canaliculus and the lacrymal sac, while the non-insulated part could occupy the lacrymal duct. The technic was as follows: After dilating the canals and finding the stricture, the insulated probe, connected with the negative pole, is introduced into the strictured portion of the lacrymal duct. Then the positive pole, wrapped in cotton, moistened in salt solution, is held in the patient's hand or introduced into the corresponding cavity of the nose. The resistance is gradually decreased for half a minute until the current measures from four to five milliamperes. The probe is then moved along the strictured portion, and the electrolysis is continued for about five minutes as a rule. The size of the probe used at first should correspond to that of the ordinary sound which just passes the stricture. Later the size of the electric probe may be increased.

## RETINAL ANÆSTHESIA AND ITS TREATMENT BY VOLTAIC ALTERNATIVES.

Dr. L. Webster Fox<sup>3</sup> defines retinal anæsthesia as a functional disorder characterized by reduction in acuity of vision and marked contraction of the visual fields ( $30^{\circ}$  to  $55^{\circ}$  in both vertical and horizontal meridians), unaccompanied by reversal in the color fields. \* \* \* \* The treatment recommended is the daily application of a weak current of 1 or 2 milliamperes, the session being of ten minutes' duration. The indifferent electrode is applied to the temple or nape of the neck; the active electrode is applied over the eye or eyes. A convenient form of electrode for this purpose is shown in Fig. 56. Improvement follows within a few

<sup>1</sup> Evetzky "On the Nature of Cataract," New York Medical Journal, July, 1880.

<sup>2</sup> Roussky Vrach, May, 1904.

<sup>3</sup> Journal of the American Medical Association, January 7, 1905.

days, and recovery is rapid. Errors of refraction should be noted, but not corrected until the cessation of electrical treatment. Voltaic alternatives are defined as a series of sudden reversals in the polarity of the electrodes of a voltaic battery, so as to produce an interrupted alternating current. The reversals used were at intervals of two seconds. Twenty-eight cases

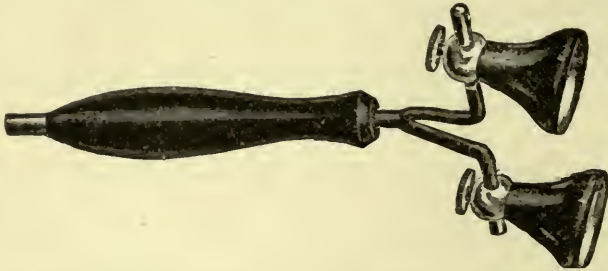

FIG. 56.—Adjustable eye electrode, for one or both eyes. Adjustable to any pupillary distance.

were treated with invariable benefit, the only return case being one of progressing myopia, which was fitted with glasses before completion of electrical course. The author asserts "eminent success in numerous other lesions of the eye, vitreous opacities, retinitis pigmentosa, chorio-retinitis, and choroiditis, treated by this method."

#### MISCELLANEOUS OPHTHALMIC AFFECTIONS.

Dr. W. Franklin Coleman<sup>1</sup> details an extensive experience with the use of electricity in ophthalmic practice, with the galvanic and sinusoidal currents.

The cases selected were very chronic and regarded as incurable; and in order that the results obtained could be ascribed to the current, the diagnosis had been confirmed by confrères and all other forms of treatment avoided.

Prior to 1890, he employed the galvanic current of zinc-carbon elements, excited by a solution of potassium bichromate; since that time, however, he has used the Edison street current, controlled and measured by the rheostat and meter of the ordinary wall plate.

The alternating or sinusoidal current was taken from a transformer, he using 30 to 35 measured volts, and a quantity measured at 5 milliamperes. With a force of 30 volts taken from the direct current, and the electrodes placed on the lids and nape of the neck, the meter registered 5 milliamperes, hence the same voltage from the alternating current and the same resistance.

He prefers galvanism, in consecutive optic atrophy, because of the existing exudates; while in primary atrophy, the alternate current would

<sup>1</sup> Transactions of the Section on Ophthalmology of the American Medical Association, Boston, June 5-8, 1906.

appear more stimulating to the nerves. This can be shown by comparing a thirty-volt current from the dynamo with a thirty-volt galvanic current; the former is not unpleasant and causes a brilliant mosaic of dark and light, while the latter causes no phosphenes, unless the current is interrupted and the burning is so intense that it cannot be endured for more than half a minute.

He summarizes his cases as follows :

*Optic Atrophy.*—Fourteen patients, 23 eyes. In 5 eyes in which vision = light, 40 per cent. were improved,—one to seeing hand movements and one to 20/67.

In 18 eyes in which vision = form, 64 per cent. were improved. Four, 60 to 125 per cent.; two, 300 per cent.; three, 500 per cent.; one, 1500 per cent.; two from seeing fingers to reading. In six there was no improvement.

*Vitreous Opacities.*—Seven patients, 12 eyes. In 5 eyes vision = light, one improved to counting fingers at 6 inches; one was unimproved. In 12 vision = form; 90 per cent. were improved; seven, 40 improved; four, 20 to 100 per cent.; six, 200 to 700 per cent.

*Amblyopia.*—Seven patients, 10 eyes, all were improved. Four, 20 to 100 per cent.; six, 200 to 700 per cent.

*Sequæ of Iritis.*—Two patients, 4 eyes. All were improved; one from light perception to 20/70; one, 100 per cent.; two, 200 per cent.

*Intra-Ocular Hemorrhage.*—One eye, vision improved from light to 20/20.

*Retinitis Pigmentosa.*—One patient. One eye improved 100 per cent.; one eye was not improved.

*Retinal Thrombosis.*—One eye, vision was improved from fingers at 14' to 6/15 and 0.5 at 12 inches.

*Sequæ Central Retinitis.*—One patient, two eyes, no improvement.

*Asthenopia.*—Three eyes. Recovered.

*Xanthelasma.*—Two patients. Recovered.

*Paresis of Ocular Muscles.*—Two patients. One recovered and one was much improved.

*Alopecia of Lids.*—One patient. Improved.

*Nictitation.*—One patient. Recovered.

*Pterygium.*—One eye. No improvement.

Thus, contrary to the contention of the erudite and lamented Noyes, and "most oculists" (Burnett), electricity does seem to justify its claim to usefulness in ophthalmic practice.



## CHAPTER X

### HIGH-FREQUENCY CURRENTS.

A COMPREHENSIVE study of high-frequency currents, the phenomena connected with them, and their remarkable modes of application, has not as yet been thoroughly mastered. Literature upon the subject is rapidly increasing, but it is a perplexing matter, in the present state of our knowledge, to discriminate between the good and the faulty. In presenting the appended chapter on high-frequency currents, no attempt at originality has been made; on the contrary, difficulty was encountered in selecting authoritative statements bearing on the subject.<sup>1</sup>

#### I. Historical Introduction.

The employment of high-frequency currents for the cure of disease was introduced to the profession by D'Arsonval. In 1842 Professor Joseph Henry asserted that the discharge from a Leyden jar was oscillatory in nature. Later Lord Kelvin, Helmholtz, and others confirmed the view advanced by Henry.

In 1881 W. J. Morton, of New York, published in the *Medical Record* an article entitled "A New Induction Current in Medical Electricity."

In 1886 and 1887 Hertz and Lodge gave to the world a study, new in conception and reasoning, that dealt with experimentation on electric waves.

In 1879 Ward asserted that sparks generated by an induction coil operated by a very rapid rotary interrupter were capable of giving 8000 interruptions per second.

In 1890 D'Arsonval showed that beyond 5000 excitations per second, the muscular contractions diminish in proportion to the increase in the number of alternations. To support this assertion, he had made an alternator capable of giving 10,000 alternations per second, and in April, 1891, he indisputably demonstrated that a current of high frequency and potential could be made to traverse the human body; increasing the oxidation consequent upon respiration, diminishing the excitability of the tissues, and lowering arterial tension.

In 1893 Oudin devised the "resonator;" but it was Tesla who, in 1891, aroused greatest enthusiasm by the employment of alternators with

<sup>1</sup> Although of late I have largely employed currents of high frequency, I have not hesitated to avail myself of the excellent work on "High-Frequency Currents in the Treatment of Some Diseases," by Chisholm Williams, published by the Rebman Company, New York.



a multiplicity of poles, and, by the introduction of transformers, he was enabled to increase the potential to an almost incredible number of volts, making possible the assertion and proof that high-frequency and high-potential currents could be made to pass through the human body, with sufficient energy to light up several incandescent lamps, without the slightest danger to the person through whom the currents were passing.

## II. Principles and Apparatus.

The nature of a discharge is dependent upon the character of the electro-motive force producing it, and likewise upon the manner of discharging it. Thus, when a ball prime conductor of a static machine is made to discharge, the discharge occurs in a disruptive manner, consisting of a series of discharges between the ball and the object at which it discharges. When a condenser, as a prime ball conductor, charged

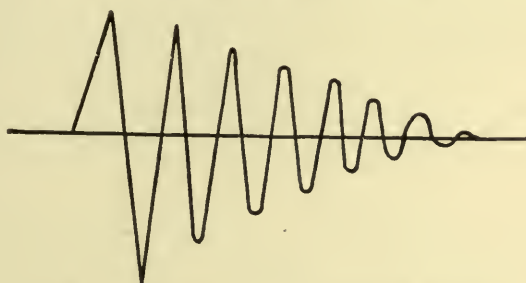

Fig. 57.—Oscillatory nature of the Leyden jar discharge.

with a very high potential, is discharged into a conductor having a certain self induction and a slight resistance, there result extremely rapid isochronous oscillations, constituting the so-called high-frequency currents. Hertz showed the frequency of these oscillations to be hundreds of millions per second. The alternations of a Ruhmkorff coil are about 200 per second, with an electro-motive force of from ten to two hundred thousand volts, while the alternations of the high-frequency currents are from 100,000 to 1,000,000 volts, depending upon the means employed.

The current is obtained from the main, bichromate batteries or from an accumulator. A Ruhmkorff coil is required to transform the current to one of high tension. The interrupter employed may be the motor-mercury interrupter, or the Wehnelt or turbine break. The alternating current generated by the coil must be transformed by the condenser into a high-frequency current. The condenser consists of two Franklin plates, enclosed in a flat box, whose exterior exhibits the small solenoid and the spark-gap with connecting screws. Another construction is where two Leyden jars are placed behind the spark-gap, and under a bell jar to

dampen the sound. Two conductors arising from the outer tin-foils of the Leyden jars end in two terminals, between which a third is interposed. As is well known, the vibrations from a Leyden jar are oscillatory in nature (Fig. 57). Where general D'Arsonvalization is required, the large and small solenoid are joined to this terminal.

The following are the principal and most widely used varieties of high-frequency current apparatus :

Morton's . . . . .	} high-frequency apparatus.
D'Arsonval's . . . . .	
Tesla's . . . . .	
Oudin's . . . . .	} resonator and its varieties.

#### MORTON'S "STATIC INDUCED CURRENT" HIGH-FREQUENCY APPARATUS.

The *modus operandi* of Morton's<sup>1</sup> apparatus is as follows: The patient is directly in circuit with the outside coatings of two Leyden jar condensers in series (Fig. 58). The spark-gap and machine are in multiple

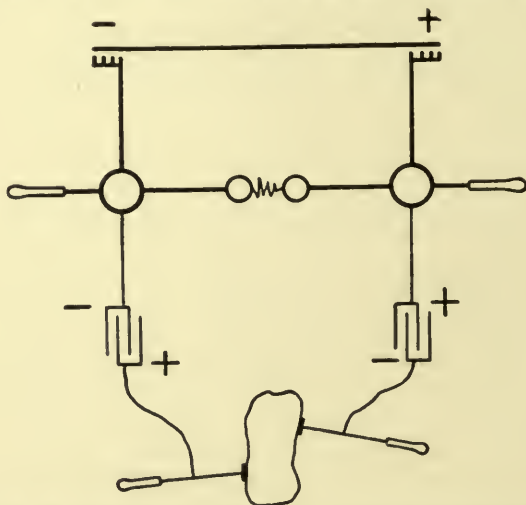

FIG. 58.—Morton's "static-induced current" high-frequency apparatus.<sup>1</sup>

with each other. With the patient included in circuit in the manner shown in the diagram we do not know the value of the inductance and resistance offered by him. The arrangement of two condensers of small capacity is conducive to the production of oscillatory currents of relatively high frequency, and such currents will be produced if the patient offers a sufficiently low resistance and inductance.<sup>2</sup>

<sup>1</sup> Journal of Advanced Therapeutics, January, 1903.

<sup>2</sup> For a detailed account see articles by Dr. W. J. Morton in The Medical Record, pp. 365-371, 395-398, 438-440, April 2, 9, and 16, 1881; and pp. 97-104, January 24, 1891.

## D'ARSONVAL HIGH-FREQUENCY APPARATUS.

In the D'Arsonval apparatus<sup>1</sup> (Fig. 59) the terminals of the secondary of an induction coil are respectively connected with one terminal of each of two condensers. A spark-gap is placed across the secondary

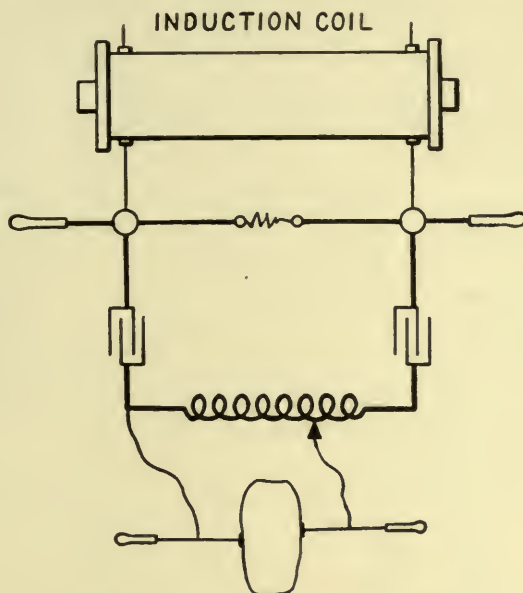

FIG. 59.—D'Arsonval high-frequency apparatus.

circuit. The other two terminals of the condensers are connected with the ends of a short coil of a few turns of thick copper wire. One electrode is connected with one end of the short coil and the other electrode is adapted by a sliding contact to include in circuit with the patient any desired length of the short coil, and thus regulate the effect produced upon him. A straight rod, or tube, of copper may be substituted for the

<sup>1</sup> In *Comptes-rendus*, vol. cxvi., 1893, pp. 630-633, D'Arsonval (quoted in the Second Report of the Committee on Current Classification and Nomenclature, and read before the American Electro-Therapeutic Association, September 24, 1903) stated in substance (a) that he had communicated to the Société de Biologie, February 24 and 25, 1891, the "astonishing fact" that when the frequency of a current was very great excitation of the nerves and muscles was not produced; (b) that the sparking distance—and therefore potential difference—between conductors connected with the ends of the short, thick wire coil was greater than at the spark-gap across the secondary terminals of the induction coil; (c) that a very strong oscillating, high-frequency current was produced, sufficient to raise a one-ampere incandescent lamp to a white heat when in series with two persons completing the branch circuit between the terminal of the thick wire coil; (d) and that he had been able to generate in a branch circuit, including his own body, a current of more than three amperes without any other effect than a sensation of heat in the hands.

short coil to increase the frequency of the current, by diminishing the inductance. A static generator may be substituted for the induction coil. Currents of exceedingly high frequency are produced by the D'Arsonval apparatus. When currents of much higher potential are desired they can be obtained from a fine wire coil of relatively many turns, inclosed in a glass tube filled with petroleum, and inserted in the thick wire coil.

That the frequency must be exceedingly high is proved by an experiment made by Dr. Sheldon. In place of the induction coil for producing the spark at the gap, he employed a Holtz machine.

#### TESLA'S HIGH-FREQUENCY APPARATUS.

This is described by its author as follows: "The writer's experiences tend to show that the higher the frequency the greater the amount of

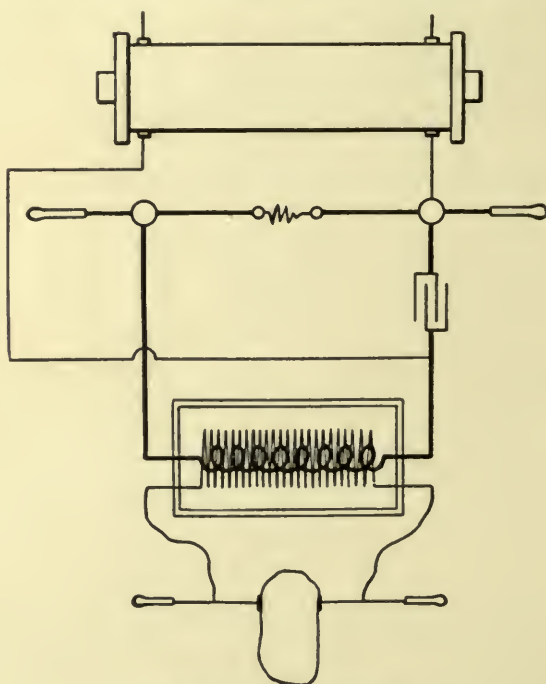

FIG. 60.—The Tesla transformer.

electrical energy which may be passed through the body without serious discomfort; \* \* \* \* By taking the globe of a lamp in the hand, and by bringing the metallic terminals near to or in contact with a conductor connected to the coil [that is to say, connected to one terminal of the secondary of an induction coil whose primary is energized by an alternating current of very high frequency], the carbon is brought to



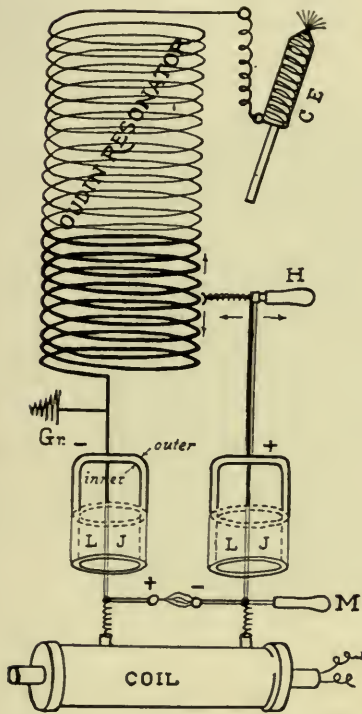

FIG. 61.—Diagram of the Oudin resonator. The Tesla coil is omitted. The current from the induction coil is connected with the inner tin-foil of the Leyden jars. The outer coat of one Leyden jar is in connection with the resonator, and is also grounded. The outer coat of the other Leyden jar is connected to the handle, *H*, which, by a sliding movement either in the vertical or the horizontal direction, decreases or increases the amount of winding of the resonator. *M* is the spark-gap for regulating the amount of current.



FIG. 62.—The Oudin resonator and Tesla coil, with electrode. (Biddle.)

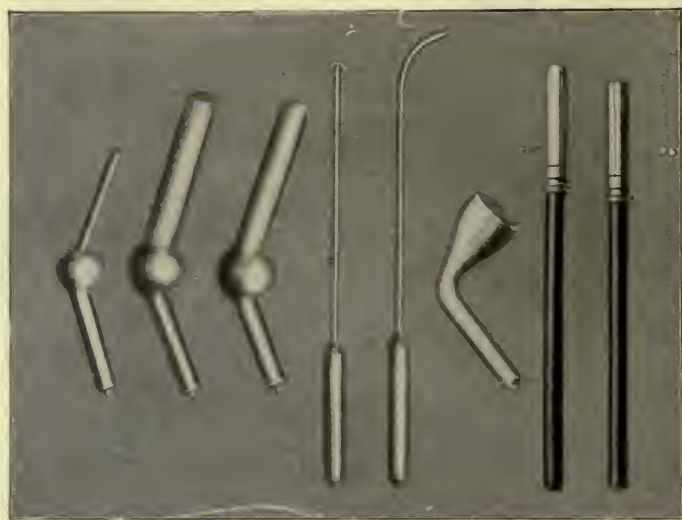

FIG. 63.—Glass electrodes. This set of electrodes has been especially designed for convenience in changing from one electrode to another. The hard-rubber handle is made very long and provided with a universal socket in which any of the electrodes may be fastened or loosened by merely moving the ring upon the sleeve which holds the stem of the electrodes.

bright incandescence and the glass is rapidly heated. With a 100-volt 10 c. p. lamp, one may without great discomfort stand as much current as will bring the lamp to a considerable brilliancy ; but it can be held in the hand only for a few minutes, as the glass is heated in an incredibly short time."<sup>1</sup>

In Tesla's apparatus (Fig. 60) the inner tin-foils of the Leyden jars are positively and negatively charged from the secondary terminals of the Ruhmkorff coil. The outer foils are in connection through the primary winding of Tesla's transformer, as is shown in the illustration, and through the spark-gap. These high-frequency alternating currents induce alternating currents in the secondary coil, combining high frequency with high tension.

#### THE OUDIN RESONATOR. (Figs. 61, 62.)

Although Hertz had previously employed the phenomenon of resonance in his experiments, it is to Dr. Oudin that the resonator owes its introduction into electro-therapeutics. The apparatus consists of a large solenoid of uninsulated copper wire of medium thickness, wound spirally about a vertical cylinder of well paraffined wood. The length of the wire employed varies from 45 to 60 meters, and its diameter from 2.5 to 3 millimeters.

It makes 50 or more turns about a wooden cylinder, 40 to 50 cm. in height and 30 cm. in diameter ; while the distance between the spirals is about 8 millimeters.

#### GLASS VACUUM ELECTRODES. (Figs. 63, 64.)

These consists of glass tubes of various shapes and sizes, which offer a barrier for retarding the entrance of high-frequency currents to the part being treated. Tesla's electrodes have as a resisting medium the rarefied air contained within them. Those of Dean are made up of a series of pieces of thick, hollow glass, in which there is a very high vacuum. The glass is sufficiently thick to prevent sparking, thus preserving the integrity of the vacuum. If the finger be approached to one of these glass electrodes when connected to the apparatus, a violet brush discharge will be observed between the glass and the finger. This discharge is produced at the outer side of the tube by induction. The better the contact between the glass and the skin, the less will be the amount of brush discharge and of heat produced. The glass tube electrode with

<sup>1</sup>Transactions, American Institute Electrical Engineers, vol. viii. pp. 267-319, New York, May 20, 1891 ; and Journal, Institution, Electrical Engineers, vol. xxi. pp. 51-163, London, February 3, 1892 ; article on Phenomena of Alternating Currents of Very High Frequency, published in the Electrical World, vol. xvii. pp. 128-130, New York, February 21, 1891.

partial vacuum becomes luminous from the discharge of the current through this vacuum, which acts as a conductor; the luminosity of the

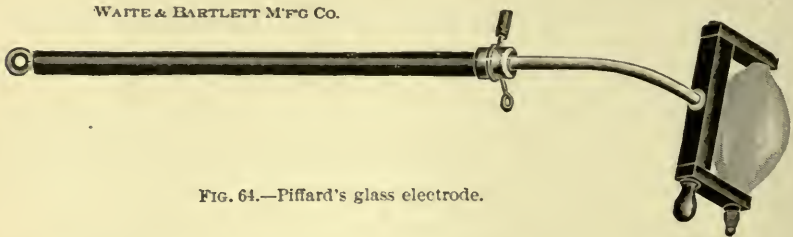

FIG. 64.—Piffard's glass electrode.

gas is due to its incandescence and tends to heat the glass wall of the tube, and these tubes occasionally crack from this cause.

#### CATAPHORESIS ELECTRODE.

The cataphoresis electrode made by K. Schall is most useful for applications to large areas, such as the abdomen, chest, and back. It has a diameter of 8 inches, and consists of an aluminium disk over which is stretched a sheet of parchment.

Dr. William J. Morton, of New York, long ago found a deficiency in vacuum tubes for phoric action, for high-frequency currents. He remarks: "A deficiency of all such electrodes is that the bulk of the current passes at the periphery of the flat disk. To obviate this I have elongated the entering metallic conductor to the region of the flat surface and have made it a sharp point.

"Again, if desired, I attach a thin metallic plate of tin-foil or other metal upon the outer side of the glass upon its flat side. The diameter

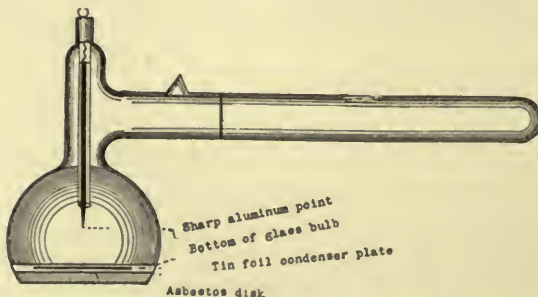

FIG. 65.—Morton's cataphoric electrode. (Waite & Bartlett Manufacturing Co.)

of this plate is considerably less than the diameter of the circular and flat surface of the electrode (Fig. 65).

"As now arranged the current's action is concentrated to this flat surface of the electrode and the cataphoric action is correspondingly



enhanced. But the tin-foil adds to the pain of the application, and I prefer to use the sharp-pointed electrode without the tin-foil condenser.”

Other varieties of electrodes are the condenser (*vide* Fig. 61, C E, *supra*) and the brush or effluve.

An effluver or electrode for applying high-frequency currents consists of a piece of metal, generally cylindrical in form, having on its upper surface a series of fine points, from which the discharge jumps to the patient. The character of the effluve may be modified by the type of effluver used: the greater the number of points, the more thinned will be the effluve (*vide* Fig. 67, *infra*).

### III. Physical Properties.

- A. INDUCTION EFFECTS.
- B. ELECTRO-STATIC EFFECTS.
- C. DYNAMIC EFFECTS.
- D. RESONANCE EFFECTS.

#### A. INDUCTION EFFECTS.

Induction effects are most intense in their action, as the apparatus giving rise to them is of a potent nature. Induction is the effect of an electro-magnetic flux on a neighboring body susceptible of an induced magnetic saturation, the intensity of the electro-motive force being proportional to that of the rate of variation of the magnetic changes or multiplied by the frequency. Therefore, upon the human body, one may bring about a high frequency and a low tension equal to that of a high tension, and low frequency on the same or equivalent mass.

#### B. ELECTRO-STATIC PROPERTIES.

Most high-frequency apparatus is so constructed as to permit of the production of physical phenomena analogous to the modern static machine. For, if we connect the two ends of the short solenoid to two plates of insulated metal which are separated from each other, a powerful electro-static field will be created; which can be demonstrated by bringing a Geissler tube between them, when a glow will be manifested, as though attached to the terminals of an induction coil. If a similar plate of glass, covered on either side with tin-foil, be interposed, and each side have attached to it a wire to which an electric lamp is fixed, it will be seen that the filament will glow; proving the presence of electrical waves proceeding from an electro-static field.

#### C. DYNAMIC PROPERTIES.

This is proved by the ease with which these currents circulate in an open circuit. Imagine a conductor connected to a high-frequency apparatus by the two poles, and in the middle of this conductor a piece of fine

wire of high resistance be interposed ; circulate the currents and the wire will glow and perhaps fuse. If sealing-wax is employed to couple the wires, the current will jump from each wire, producing sufficient heat to fuse the wax.

#### D. RESONANCE.

A resonator is an accessory to the apparatus, whose purpose is to augment the tension of the current and to create in the vicinity a more powerful electro-static field. When two bodies vibrate in unison they are said to be syntonous. The Hertz resonator is one of low resistance and capable of giving very rapid oscillations, it is likewise of small capacity and self-induction. It consists of an induced current formed by a length of copper wire so bent as to form nearly a circle, but having two balls at the extremities where they are brought near one another.

This resonator is brought into the field of another vibrator and tuned in syntonny with the latter ; as soon as the resonator is put in action, Hertz's resonator will emit sparks from the two balls. All the other resonators are founded on the above principle.

#### IV. Methods of Application.

There are four chief methods of applying high frequency currents, as distinguished by D'Arsonval :

1. Direct application or by derivation.
2. Indirect application or auto-conduction by the solenoid.
3. Auto-condensation (Apostoli).
4. By local application.

##### 1. DIRECT APPLICATION.

Connect the patient by two large handles to the ends of the small solenoid. The currents will pass through him by derivation ; for by virtue of the phenomenon of self-induction, the solenoid offers a great resistance, which can be proved by interposing an incandescent lamp in the circuit, when it will glow. If the connection between the patient's skin and the handles be defective, small sparks will be observed to pass. To increase the area of penetration, connect some part or member of the patient to one end of the small solenoid, and the other end to a metallic plate in the water of the bath, near, but not in contact with the skin. If the contact be imperfect, small ulcers may result. With powerful installations, when the handles are used after prolonged electrification, and with 500 or more milliamperes, heat and tingling may be experienced in the hands and arms. The above methods are termed stable or bi-polar.

In the labile method, a fixed electrode connects the patient to the solenoid. The other end is manipulated by the physician, who, with an insulated handle, is enabled to apply its electrode end to the desired part. In approaching the skin with the insulated electrode, sparks appear, and the momentary contact produces an erythematous flush.

The séances should be brief. In systemic affections begin with a few minutes' direct auto-condensation or auto-conduction every day. Note any subjective symptoms. If the dosage has been in excess, the patient experiences a feeling of fatigue. The D'Arsonval milliamperemeter should be employed, the range of which should extend to 700 milliamperes.

In the local treatment we observe that a reaction is produced at the time and continues for some hours thereafter. Thus, in a patch of lupus vulgaris, a glass electrode of low resistance connected to the free end of the resonator and placed in actual contact with the patient would be used, and by a judicious choice of the number of spirals called into play, the discharge is reduced to almost *nil*. After an application lasting five minutes, the part feels hot and looks inflamed. The warmth increases until the sixth hour, but by the following morning has entirely disappeared. The inflammation, however, has persisted. After a few séances the patch dries up and scales, but the pigmentation remains.

The treatment may be applied once or twice daily for two weeks, then once daily, or every other day, for the same period, reducing the number of applications week by week.

An acute pain, produced by disease, will be augmented at the commencement of energetic treatment. Defective contacts between the patient and the apparatus, or in the apparatus itself, may cause unpleasant sensations or shocks.

## 2. AUTO-CONDUCTION BY THE SOLENOID.

By this method (Fig. 66) the patient is not in actual contact with the solenoid; his body becomes saturated in the field of the current,—*i. e.*, sparks may be drawn from him. If a lamp of 20 volts be used to close the circuit of a single coil of thick wire, it illuminates with a bright light at a distance of more than three feet.

Place the patient in a large solenoid, and have him join his arms so as to form a circuit, which is completed by an incandescent lamp, the terminals of which communicate with the hand. The lamp is lighted with the induced current in the circuit thus formed. Any conducting body placed in this field becomes influenced with induced currents, and if a single copper wire of one turn is introduced, the induction produced in the latter will be sufficient to light up two lamps of 110 volts mounted in series.



### 3. AUTO-CONDENSATION.

In this method the patient is attached to the solenoid in the usual way, but the other end is attached to a large metallic plate, brought near the patient, but insulated from contact with him. Thus the metal plate and the body of the patient form the armatures or coatings of a condenser arrangement, having a large electrical capacity, which is charged and discharged as the potentials at the extremities of the solenoid vary. The patient lies upon the insulating cushions of the couch, the current passing to him either by a handle of bare metal held in the hand, or by an electrode applied to the desired part.

### 4. LOCAL APPLICATIONS.

These are especially applicable in the form of brush discharges (Fig. 67). Potentials as high as possible are required for these discharges. This may be accomplished by employing a secondary coil, which is oil immersed, or air insulated. In 1892 Oudin devised his resonator, made of an open solenoid of wire, which could be connected as an extension of one end of the solenoid of a high-frequency apparatus, and served, when carefully adjusted, to raise the potential to such an extent that a long brush discharge could be obtained from its free extremity.

## V. Physiological Properties.

Currents of high frequency and high potential produce no action on sensory or motor nerves. When a person or a number of persons are placed in the external circuit, and there are interposed incandescent lamps of 125 volts, one ampere, the filaments will light up, without producing sensations in the persons in the circuit. With more intense currents, only a slight sensation of heat will be perceived at the point of entrance and exit.

H. Lewis Jones controverts the assertion, maintaining that if the current in each lamp had been three amperes, it would certainly have destroyed life, whether the direct or the alternating current had been employed.

It has been argued that the incandescence occasioned in the lamp is caused by the increased resistance in the filament of the lamp, due to the very high frequencies, and that a smaller current at a proportionately high voltage will make it glow.

Another theory advanced to account for this phenomenon, is that the rushes of current are very considerable while they last, but their duration is so very brief, that the total current passing in a given time is relatively small. Others maintain that a molecular bombardment, rather than an electric current, is really the energy dissipated. D'Arsonval



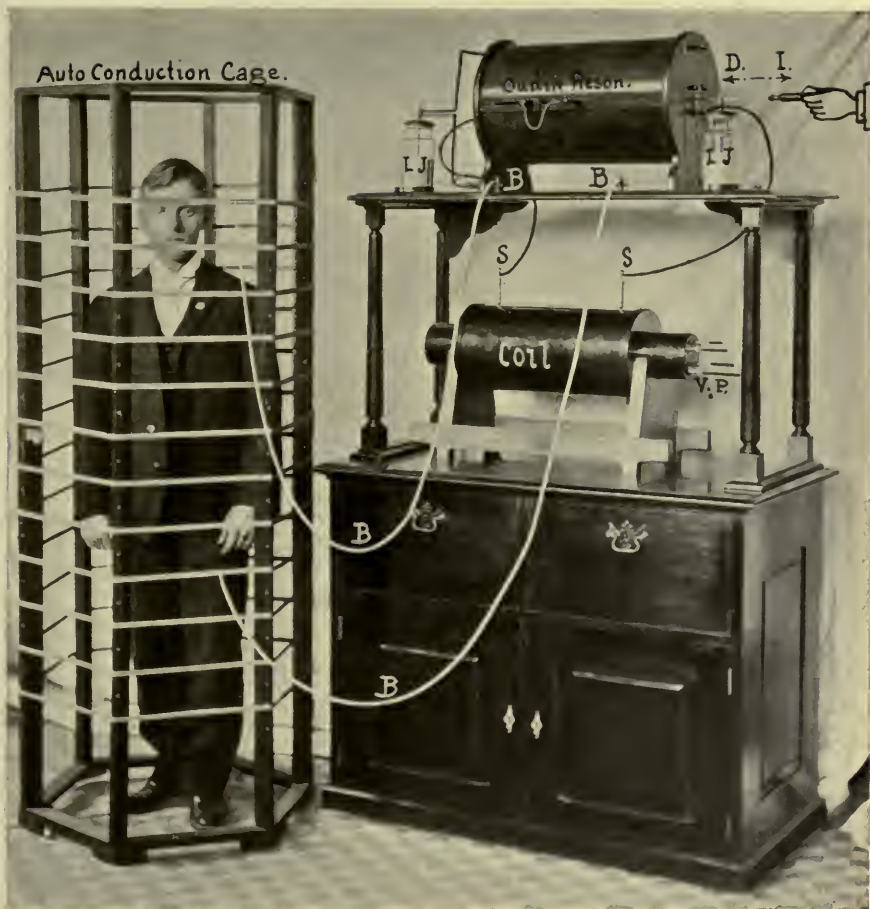

FIG. 66.—Treatment by auto-conduction. *S S*, secondary terminals of induction coil; *B B*, cords to the auto-conduction cage from the Oudin resonator; *L J*, Leyden jar; *D*,  $\longleftrightarrow$  *I*, spark-gap; when sliding in the direction "*D*," the current suffers a loss in intensity, and vice versa.



FIG. 67.—Treatment by the effluvia method. The condenser electrode, *B*, is in connection with the top of the resonator. Patient is seated upon an insulated platform, holding the electrode, *A*, which is the other pole, from the outer side of the Leyden jar, *L J*. (By grounding the outer side of the Leyden jar, *A*, the patient's insulation is unnecessary and better effluvia is attained.) *S. M.* is the spark-gap.

affirms that currents of ten times less intensity would be extremely dangerous if the frequency were decreased from 500,000 to 1,000,000 per second, to 100. Tesla inclines to the belief that the harmlessness of these currents is due to their lack of penetration of the body at the point of contact of the electrodes, but that the current traverses the subject in a path perpendicular to the skin and equally over the entire surface. D'Arsonval declares that motor and sensory nerves are so constituted as to respond to vibrations of a certain frequency, studying the phenomenon of neuro-muscular excitement when one increases the number of electrical vibrations indefinitely. He has demonstrated that the waves (each of which produces a muscular shock if sufficiently distanced) no longer produce the same effect if there is an augmentation of their number in certain limits per second. Gradually there is a fusion of the contractions, which ultimately results in a tetanized condition. In order to arrive at this condition, twenty to thirty excitations per second are required. The muscle being tetanized, if the number of waves be increased, the phenomenon of neuro-muscular excitement is increased equally till a maximum is reached, which corresponds to 2500 or 5000 vibrations per second. From this moment the excitation decreases as the number of vibrations per second increase.

D'Arsonval regards these currents as inhibitory in nature, because of the local anaesthesia occurring at the point of entrance of the current, which lasts from one to twenty minutes; and also that the excitability of the body to other stimulation is decreased under the influence of these currents. He has likewise observed a fall of arterial tension in the dog, and lastly, that the sensibility of the skin to galvanism and faradism is materially decreased after the passage of high-frequency currents, although a greater strength of the former currents can be tolerated, than before electrification.

## VI. Applications in Various Diseases.

### TUBERCULOSIS.

Mr. Chisholm Williams<sup>1</sup> advocates the employment of high-frequency currents in phthisis. In a series of forty-three cases, he found that by the use of these currents there was a marked improvement in weight, appetite, and digestive power. For a time the temperature became elevated, and the tubercle bacilli in the sputum increased in numbers. Later the temperature dropped to normal, the bacilli decreased, and the patient's general condition was materially improved. In 1903 thirty-nine of the forty-three patients were alive, and in one instance the disease appeared entirely arrested. Dr. H. E. Gamlen<sup>2</sup>

<sup>1</sup> British Medical Journal, October 12, 1901, and October 24, 1903.

<sup>2</sup> Archives of the Röntgen Ray, January, 1906.



likewise reports excellent results, by the use of high-frequency currents in tuberculosis. Dr. Alfred Goss<sup>1</sup> remarks: "By the method described I have treated in the past two years a little over two hundred cases, but on account of failure to keep my records accurately previous to June 1, 1905, I report my cases from that time, and will merely state in regard to the previous cases that I had forty-four cases out of eighty recover within a period of six months. Since June 1 I have one hundred and seventeen cases recorded, with thirty-eight absolute recoveries so far as after repeated examinations no tubercle bacilli showed in the sputum. They regained their weight and ran a normal temperature. They have since been living in various sections of the country and still remain well, performing their usual avocations."

#### GOUT.

In this disease high-frequency currents alone, or in combination with other forms of electricity, have been employed. When used alone, auto-condensation and auto-conduction have been chiefly employed. These currents must not be applied during an acute paroxysm. Low intensity and brief duration of séances should first be used, and they should be progressively increased. The treatment should be continuously applied within short intervals for several months.

#### RHEUMATISM.

This affection has been successfully treated by daily applications of high-frequency currents by means of auto-condensation, séances of ten minutes' duration. At the end of seven weeks the urine was normal, treatment was stopped, pain ceased, appetite returned, and the patient regained his natural sleep. In the seven weeks of treatment, his weight increased  $6\frac{1}{2}$  pounds. In chronic rheumatism the greatest benefit is derived from high-frequency currents. The same statement is vouched for by Gamlen.<sup>2</sup>

#### OBESITY.

Foveau de Courmelles was the first to study the effect of high-frequency currents on this condition. Boinet and Caillol de Poney<sup>3</sup> published a report of a series of cases where the decrease in weight averaged 14 pounds per month. All of these cases were treated by auto-conduction. In this class of patients, urinary findings show an increased excretion of urates and phosphates.

<sup>1</sup> Medical Record, June 9, 1906.

<sup>2</sup> Ibid.

<sup>3</sup> Soc. de Biologie, July 31, 1897.



## HYSTERIA.

In these cases the patient gains in general condition, in weight, etc. The improvement noted is about on a par with the Weir-Mitchell rest cure. In sciatica, neuralgia, tabes dorsalis, and chorea, Gamlen has achieved excellent results with high-frequency currents.<sup>1</sup>

## LUPUS VULGARIS.

It would appear that high-frequency currents in this disease behave in a manner similar to the X-rays or the Finzen light. Williams reports that twenty applications of five minutes each, over a period of ten weeks, suffice to clear up any non-ulcerated small patch of lupus. The effluve, the high-vacuum glass electrode emitting X-rays, or the ordinary glass electrode may be employed.

## RODENT ULCER AND MALIGNANT DISEASES.

In rodent ulcer the effluve can be readily and advantageously applied. In an interesting case of that disease, Williams records how he used his thumb as an electrode, the patient being on the auto-condensation couch, and connected to one pole; the other was connected with the operator, and the circuit completed by the latter's thumb on the ulcer. At the end of the first three applications the dry serum became attached to the thumb; each additional application seemed to shrink more of the ulcer. The hard edges, so resistant at first, disappeared, and for eleven months there has been no evidence of a return. The applications are painless. Relapses are extremely rare. In 1901 Dr. Allen, of Chislehurst,<sup>2</sup> published an elaborate report of malignant disease treated with high-frequency applications. The results he obtained were most encouraging, some apparent cures being recorded.

## PILES, RECTAL FISSURES, AND PRURITUS ANI.

In all three of these conditions, high-frequency currents have proved most efficient. A special electrode, consisting of a stem with a bare conical metallic extremity, is employed. Doumer has reported 26 cases of hemorrhoids, with more or less successful results. Benefit is most pronounced in recent acute cases, with marked structural changes. Mr. F. J. Bokenham<sup>3</sup> offers a summary of results obtained in two years and a half, with currents of high frequency, in the treatment of hemorrhoids, rectal fissures, and pruritus ani. The number of cases treated was 118. He records 52 as completely cured, 37 as greatly relieved, 18 were improved, and the remaining 11 he pronounces failures. He prefers to

<sup>1</sup> Ibid.

<sup>2</sup> Medical Electrology and Radiology, vol. v., page 43.

<sup>3</sup> Lancet, July 2, 1904.

employ high-vacuum glass electrodes. With metal electrodes he uses a current of 450 to 500 milliamperes; with glass electrodes, 100 to 150 milliamperes. Duration of each séance about 5 minutes; he believes that no one treatment should ever exceed 15 minutes in duration.

#### COLITIS.

Shenton<sup>1</sup> remarks that a valuable use of high-frequency currents consists in their beneficial effects in mucous and ulcerative colitis. In the first case reported by the author, the abdomen was exposed almost daily to weak X-rays for a month, but without effect. High-frequency treatment was then given on the condenser couch, for a period of ten minutes through the hands, followed by a fifteen-minute local application, sometimes from the low tension and sometimes from the resonator. This resulted in improvement of the general condition, and gradually the diarrhœa, hemorrhage, and pain diminished. The treatment was continued nine months and resulted in complete cure. Seven other cases subsequently treated, resulted in improvement in the general health, increase in weight and appetite, and improvement in sleeping. In all of the cases but one, the results were considered satisfactory.

#### OZÆNA.

Hahn<sup>2</sup> used the high-frequency currents by means of a special nasal electrode in the treatment of ozæna. Bordier and Collet in 1902 applied high-frequency currents in the treatment of ozæna, and since then Hahn has used this method in seven marked cases of the disease. He used an Oudin resonator with an electrode similar to that used by Bordier and Collet, namely, a metallic rod covered with paraffin or wax, and placed in an insulating handle. The electrode may also be enclosed in a glass tube, which allows only the tip to project. Care must be taken to apply the effluvia to every part of the affected mucosa. The smaller the sparks, the less irritation and reflex action will there be. No cocaine or adrenalin was needed before applying the high-frequency current, but the patient sneezed a few times after the current was turned on, complained of burning, slight pain, and lachrymation. But these symptoms vanished in two or three minutes if the application was continued. After three minutes the electrode was withdrawn and the patient was asked to blow his nose, when all the crusts usually came away at once. The séance was repeated in from seven to forty-eight hours, and lasted usually about fifteen minutes, although it can be made twice as long without harm. No other treatment, not even irrigation, was used. While the author does not allege absolute cures in his seven cases, the improvement

<sup>1</sup> Archives of the Röntgen Ray, August, 1905.

<sup>2</sup> Gazzetta degli Ospedali, delle Cliniche, March 5, 1905.

was very marked indeed, and the mucous membrane in some cases assumed a more normal aspect. In all cases the crusts disappeared and the odor was removed, while the subjective symptoms, including the headaches, were almost abolished. He believes that high-frequency currents have an antiphlogistic and resolvent action upon the mucosa of the nose in ozæna.

#### EPILEPSY.

The following detailed reports of the clinical application of high-frequency currents represent some of the more advanced views on the therapeutic value of this agent.

Concerning the treatment of epilepsy, Dr. Samuel G. Tracy<sup>1</sup> says: "The galvanic and faradic currents of electricity have been used in former years, but with little success. If Hughlings Jackson's theories regarding the nerve system are correct, it is reasonable to suppose that high-frequency, high-potential electric currents will have a beneficial effect on the nerve centres, and indirectly on epilepsy.

"As a rule each patient should be treated every other day, first receiving X-radiation from 5 to 10 minutes from a high tube. This is placed about 6 to 10 inches above the head, so that the rays strike directly upon the anterior and occipital part of the brain (Jackson's centres of high level). After the X-radiation the patient should be subjected to the influence of a high-frequency current, applied over the brain for 10 minutes, and for 5 minutes over the spine. In this manner I have treated the different forms of epilepsy, but I found the best results were obtained by using the combined treatment of X-radiation and high-frequency currents with small doses of bromides. By this latter method at least 25 per cent. of cases of *petit mal* may be considered tentatively cured, 20 per cent. of Jacksonian epilepsy, and 12 per cent. of *grand mal*. All cases were improved more or less, not only in regard to the frequency of the epileptic seizures, but also in regard to their severity. In addition to this the general mental and physical condition was very much improved. As these experiments have been continued for less than a year, sufficient time has not elapsed to say how much permanent value there is to this method of treatment. Nevertheless, such progress has been made in the cases treated that I believe we are on the right road to get the best results in the treatment of epilepsy.

"I am inclined to believe that the high-frequency currents have some chemical effect on the bromide, possibly liberating a larger quantity of the bromide as the solution of the salt circulates in the brain, and thus the drug in smaller quantities has a more pronounced therapeutic effect in controlling the epileptic seizures."

<sup>1</sup> New York Medical Journal, March 4, 1905.



## SKIN DISEASES.

Dr. Charles W. Allen<sup>1</sup> reports 175 cases of various skin diseases treated since November, 1901. In chronic eczema he has found the discharges of vacuum electrodes of decided value in alleviating symptoms and in diminishing infiltration. In herpes zoster of the thigh and arm with hyperæsthesia and neuralgic pain, not only has temporary relief been afforded immediately after each application, but the whole course of the disease has been shortened and the lesions have promptly healed.

General effluvia with metallic pointed electrodes, the so-called "feather-duster" brush, seems to diminish the pruritus, to shorten the attack, and decrease the duration of the entire course in subacute and persistently recurring urticaria. Dr. Allen believes that high-frequency currents are of decided advantage to those treating skin diseases, in conjunction with other measures. They are curative of themselves in a restricted class of cases and efficiently meet pruritic symptoms; but these currents are inferior to the X-rays in skin diseases, the best work being accomplished when they are used conjointly, as I have frequently seen.

## TRACHOMA.

In the treatment of trachoma, Stephenson and Walsh<sup>2</sup> believe a promising field has been opened as a result of their work with the X-ray irradiation and the high-frequency current.

In one case, after 22 applications by the high-frequency current a case of trachoma was apparently cured. A 12-inch spark-coil (Cox) was run from the main connection with a D'Arsonval high-frequency apparatus. One end of the solenoid was earthed, while the other was connected with a vulcanite electrode, with which the closed eyelids were gently massaged. A small brush discharge of about half an inch was obtainable from the electrode, which would probably have acted upon the trachoma equally as well without actual contact of the electrode with the lids. So far as can be ascertained, this is the first application of the high-frequency current to the eye. By this means, as with the focus tube, more improvement has been effected than could have been expected from the prolonged use of escharotics.

## DULNESS OF HEARING AND SUBJECTIVE NOISES.

Dr. J. G. Connal<sup>3</sup> says in reference to dulness of hearing and the occurrence of subjective noises: "The cases were of a class not readily influenced by ordinary methods of treatment. The types selected were: (1) chronic dry catarrh of the middle ear with secondary labyrinthine

<sup>1</sup> Medical Record, February 20, 1904.

<sup>2</sup> Medical Press and Circular, No. 7; Progress of Medical Science, 1903.

<sup>3</sup> Journal of Laryngology and Rhinology, August, 1904.



involvement; (2) chronic dry catarrh of the middle ear without marked labyrinthine involvement; (3) sclerosis of the middle ear; (4) post-suppurative conditions of the middle ear (the purulent process having ceased), leaving a cicatrix or a dry perforation with or without calcareous deposit in the tympanic membrane; (5) primary labyrinthitis (traumatic); (6) tinnitus without dulness of hearing. In all the cases both ears were involved, one ear generally being worse than the other.

Results: 1. Six cases. No improvement in the hearing of any of them. In four the tinnitus persisted; two thought the noises were slightly lessened, but were not at all certain. 2. Fourteen cases. In ten, no improvement in hearing; one was worse; two noted a slight improvement in the hearing. One patient said she heard much better, but the improvement was not appreciable by the tests applied. Of the ten patients who complained of tinnitus, eight reported an improvement; two of these said they were very much better. In one case the noise disappeared entirely in one ear for six weeks, when it recurred. 3. Five cases. One patient said she heard better, but did not respond to tests; four reported an improvement in the hearing, confirmed with the watch, and improvement in the tinnitus. 4. Seven cases. Four reported a slight improvement in hearing, and four or five who had tinnitus reported improvement. 5. One case. No benefit. 6. One case. No benefit. The author urges the importance of technic in the electrical treatment of these cases. The common method of applying the current is by means of the effluve (spray). This method was adopted in the earlier cases, but was found unsatisfactory. The method of using a condenser electrode in each ear was substituted and gave better results, probably because the current is more completely concentrated on the ears.

#### GONORRHOEA.

Gamlen<sup>1</sup> treated a rebellious case of gonorrhœa by high-frequency currents, by means of a bougie connected with the terminal on the top of the resonator. At the same time, general high-frequency currents were administered. Sixteen of these combined treatments effected a cure. Local treatment was given every second day; duration of each treatment was five minutes. He also mentions the case of a young woman, with a history of gonorrhœa of three weeks' duration. The usual medicinal treatment proved futile; high-frequency treatment was instituted and a vaginal glass electrode was employed. "After the first few applications," says Gamlen, "the irritation, and later the discharge, gradually subsided. Fourteen applications effected a complete cure."

<sup>1</sup> Archives of the Röntgen Ray, February, 1906.

## PART II

### THE RÖNTGEN RAYS IN DIAGNOSIS

---

#### Historical Introduction.

THE discoveries made and the achievements wrought in the domain of electricity are the recorded efforts of determined and conscientious minds of all ages. From the remotest periods of the world's history the mysterious phenomena of electricity have arrested attention and invited thought from searching inquirers, and slowly but surely the hidden secrets of this subtle force of nature have been steadily unfolded, until to-day the mighty achievements ascribable to it confront us on every side, offering a telling contrast to the methods pursued a few centuries ago, when men with crude appliances and still cruder ideas led the van in experimental inquiry.

To Otto von Guericke, the world owes a debt of gratitude for his successful labors in inventing, in 1650, the air-pump and in ingeniously applying it to the laws of science. In 1740 Abbé Nollet employed the air-pump and continued the studies commenced by von Guericke. It remained for Sir W. Snow Harris, in 1834, to formulate boldly the statement, that the length of the spark which an electric machine will give in the air varies as the inverse ratio of the pressure of the gas.

In 1838, the immortal Faraday challenged the world's admiration with his experiments in electricity, and simultaneously his celebrated confrère, Heinrich Geissler, made memorable that scientific epoch, by improving on the efforts of Faraday in his study of electric glow discharges. The principles of and the laws governing electric science were being surely evolved, when in 1840 Clerk Maxwell turned the search-light on this special department of science, and gave to the world the electro-magnetic theory of light.

Sir William Thomson (now Lord Kelvin), not unmindful of the laborious researches of Sir W. Snow Harris, determined to make a profound study of the relation existing between gas pressure and spark length, and in 1860 he gave to science the absolute electrometer, an invention that at once brought his name into commanding prominence. The substitution of the Ruhmkorff coil by cells was the very original thought that occupied the attention of Gassiot. With a battery consisting of more than 3500 cells, this celebrated French physicist proved

conclusively that a vacuum tube glowed incessantly when placed in the path of its circuit, and in 1865, Hermann Sprengel invented the mercury air-pump, an instrument devised for the purpose of producing very high rarefactions, with a great degree of rapidity.

In 1869, Hittorf's name became familiar for experimentations along these lines, and the same work was largely followed by Goldstein in 1876. It was during the latter year that the brilliant researches of Gassiot were being still further prosecuted. In 1877, a coterie of scientists were eager to take up the work where Gassiot had left off; not the least conspicuous among these were Warren de la Rue, Hugo Müller, and W. Spottiswoode.

From 1877 to 1879, investigators were making extended studies and investigations into the theories already advanced, and perfecting with unremitting energy the practical points previously deduced. In the latter year the celebrated Sir William Crookes startled the world by his announcement that matter was radiant. It was he who declared that the particles that were shot off from the cathode ray possessed strange and remarkable properties.

In 1883, Wiedemann and J. J. Thomson continued these studies and declared these particles to be ether disturbances of very short wave length. The study was continued by Professor Hertz at Bonn, leading to an investigation of high vacua discharge experiments. The work was continued by his assistant, Professor Lenard, who in 1894 proved the possibility of cathode rays passing through the walls of a vacuum tube. Perrin, in France, and Elster and Geitel in Germany, made searching studies into the latter subject.

It was in 1895, that Professor Röntgen was experimenting with Lenard and Crookes tubes when an unusual phenomenon met his gaze. His tube was completely enveloped in an opaque cover, when a near-by paper containing a fluorescent substance exhibited a most pronounced visible glow! How could the phenomenon be explained? The rays offered a triumphant resistance to the action of the magnet. These were the rays so indispensable to the photographer's art; the rays that were destined to revolutionize many preconceived notions in medicine and surgery. A new radiation had burst forth at the touch of genius; a new science had come into being.

Wilhelm Conrad Röntgen was born in Lennep, Province of the Rhine, Germany, March 27, 1845. At an early age the boy showed a remarkable aptitude for study, and in 1870 he was graduated as a Doctor of Philosophy from the University of Zürich. Seeing that the youth gave promise of a bright career, Professor Kundt took a lively interest in the young man, and in 1873, when Kundt was elected to a chair at the University of Würzburg, the young scientist accompanied him, and at



Professor Kundt's promotion to the University of Strasburg, Professor Röntgen became his assistant. In 1875, Professor Röntgen was made Professor of Mathematics and Physics in the Agricultural Academy at Hohenheim, retiring from the institution to return to Strasburg just one year later. In 1879, he accepted a call as Professor and also as a Director of the Department of Physics at the University of Giessen; he likewise accepted a similar position at the University of Würzburg,—the latter office he still holds.

The labors of Professor Röntgen have been manifold; he has had published his investigations on isothermal crystals, solar calorimetry, dust figures, aneroid barometry, absorption of heat by various vapors, etc. During the past decade his studies have been almost exclusively devoted to problems in electricity. Space forbids naming even a tithe of the honors that have been showered upon this celebrated scientist. Requested by the German Emperor to demonstrate his discovery at the Palace at Potsdam, the Emperor decorated him with a Crown Order of the Second Class. The University of Munich presented him with a professorship in recognition of his immortal discovery. He was awarded the Barnard medal from the National Academy of Sciences at the commencement exercises of Columbia University, New York City, and he also received the Nobel prize in 1901.

### **The Comparative Study of the Properties of the Cathode and the Röntgen Rays.**

#### **CATHODE RAYS.**

*Production.*—Much discussion has arisen as to the true character of the cathode rays. One school of philosophers declare that they are not rays of light, but merely a stream of molecules proceeding from the cathode; others adhere to the view that these rays are analogous to ordinary light rays, and represent some process occurring in the atmospheric ether. Nevertheless the fact remains that, for their production, it is essential to have a certain degree of vacuum in the tube. If this degree of vacuum be increased, the production of cathode rays is no longer possible, and when the tube is as completely exhausted as is possible, the production of X-rays occurs. Cathode rays can be produced only within the walls of the glass tube, and must be studied outside of the tube by the introduction of Lenard's aluminium window.

*Radiability.*—Professor Hertz was the first to demonstrate authoritatively that thin sheets of metal were transradiable, and Lenard showed the phenomenon to be true of thin layers of other substances opaque to light. Gold, silver, and aluminium foil allowed the passage of the rays without suffering loss of any of their intensity. With gases, it was found



that the power of penetration varied inversely as the density,—*i. e.*, the greater the density the less the penetrability. Water was found to be transradiable only in extremely thin strata.

*Fluorescence and Phosphorescence.*—Experimentation has proved that the phosphides of the alkaline earths, calc spar, and uranium glass glow brilliantly when near the aluminium window. Salts of manganese, cadmium, strontium, and lithium luminesce brightly. Liquids are inactive. A rather curious fact is, that the sulphate of quinine in solution is only slightly excited, but the same salt in the solid state offers a most brilliant glow of a deep blue color. Lenard affirms that the platino-cyanides exhibit colors, similar to those that are produced under the influence of the ultra-violet rays.

*Reflection, Refraction, and Polarization.*—In the vacuum tube the cathode rays appear to be reflected and to behave in the same manner as rays of light. Nothing definite has been determined regarding the polarization of these rays.

*Chemical and Photographic Effects.*—The cathode rays possess a most energetic chemical action on the alkaline haloids, and on some of the haloids of the earths. Thus lithium chloride suffers a change to violet, whilst sodium chloride can be made to change to either a yellow or a gray color. Upon heating, the former is converted into a red color; the latter blue. The cathode rays act energetically on photographic papers and plates; thus iodine paper is quickly converted to a pronounced blue on exposure to the rays.

*Physiological Effects.*—Neither the eye nor the skin is affected by the action of the cathode ray; a characteristic odor and taste are produced, but by some authorities these are ascribed to the presence of ozone.

*Theories.*—The theories advanced to explain the cathode rays are the hypotheses put forth by the leading exponents of the English and German schools of philosophers. The former physicists incline to the belief that the cathode rays are streams of electrified molecules that are shot off from the cathode; in contradistinction to the German scientists, who hold that these rays are manifestations of ethereal vibrations; defending this statement with the results of Lenard's investigations, and declaring, with that scientist, that cathode rays are propagated through a vacuum in straight lines, and so void of all matter that through them an electric spark cannot be made to pass.

Jaumann's theory, which brings into the discussion the subject of longitudinal waves, has received some support. He asserts that when these rays are incident at right angles there is caused a high discharging effect, showing a large longitudinal component. This theory gains corroboration in a magnetic field. In accordance with this investigator's views, these rays can only be normally reflected when the force applied

is parallel to the reflecting surface. Space forbids the presentation of many other ingenious theories, advanced by Wiedemann, Hertz, Goldstein, Prout, and J. J. Thomson.

#### RÖNTGEN RAYS.

*Production.*—The new radiation—that form of energy called the Röntgen rays or the X-rays, requires for its production a highly exhausted discharge tube. It must be borne in mind that the essential factor in the generation of the Röntgen rays is that the electric discharge must be made to take place in a high-vacuum tube, such as the Crookes tube; other circumstances, as the character of the coil or dynamo, being matters of minor consideration. Again, if we take Geissler tubes, which are bulbs in which the air is only partially exhausted, we obtain what is known as a low vacuum, and it is difficult, or indeed impossible, to generate Röntgen rays from such a discharge apparatus. The Röntgen rays require the one-millionth part of atmospheric pressure.

*Radiability and Penetrability.*—The peculiar power possessed by the Röntgen rays, of penetrating substances opaque to ordinary light or cathode rays, has been shown by Professor Röntgen to be largely dependent upon the relative density and thickness of the substance under examination.<sup>1</sup> In an elaborate exposition in his first communication, he says:

“Sheets of hard rubber several centimetres thick still permit the rays to pass through them. Glass plates of equal thickness behave quite differently, according as they contain lead (flint-glass) or not; the former are much less transparent than the latter. If the hand be held between the discharge tube and the screen, the darker shadow of the bones is seen within the slightly dark shadow-image of the hand itself. Water, carbon disulphide, and various other liquids, when they are examined in mica vessels, seem also to be transparent. That hydrogen is to any considerable degree more transparent than air, I have not been able to discover. Behind plates of copper, silver, lead, gold, and platinum the fluorescence may still be recognized, though only if the thickness of the plates is not too great. Platinum of a thickness of 0.2 mm. is still transparent; the silver and copper plates may even be thicker. Lead of a thickness of 1.5 mm. is practically opaque; and on account of this property this metal is frequently most useful. A rod of wood with a square cross-section (20 x 20 mm.), one of whose sides is painted white with lead paint, behaves differently according as to how it is held between the

<sup>1</sup>In this and the succeeding paragraphs the quotations have been taken from “Röntgen Rays;” embracing Professor Röntgen’s original communications to the *Physikalisches Institut der Universität, of Würzburg*, and translated by George F. Barker, LL.D.; Harper and Brothers, Publishers.

apparatus and the screen. It is almost entirely without action when the X-rays pass through it parallel to the painted side; whereas the stick throws a dark shadow when the rays are made to traverse it perpendicular to the painted side. In a series similar to that of the metals themselves, their salts can be arranged with reference to their transparency, either in the solid form or in solution.

“The experimental results which have now been given, as well as others, lead to the conclusion that the transparency of different substances, assumed to be of equal thickness, is essentially conditioned upon their density; no other property makes itself felt like this, certainly to so high a degree.

“The following experiments show, however, that the density is not the only cause acting. I have examined, with reference to their transparency, plates of glass, aluminium, calcite, and quartz, of nearly the same thickness; and while these substances are almost equal in density, yet it was quite evident that the calcite was sensibly less transparent than the other substances, which appeared almost exactly alike. No particularly strong fluorescence of calcite, especially by comparison with glass, has been noticed.

“All substances with increase in thickness become less transparent. In order to find relation between transparency and thickness, I have made photographs in which portions of the photographic plate were covered with layers of tin-foil, varying in the number of sheets superposed. Photometric measurements of these will be made when I am in possession of a suitable photometer.

“Sheets of platinum, lead, zinc, and aluminium were rolled of such thickness that all appeared nearly equally transparent. The following table contains the absolute thickness of these sheets measured in millimetres, the relative thickness referred to that of the platinum sheet, and their densities:

Thickness.	Relative Thickness.	Density.
Pt 0.018 mm. ....	1	21.5
Pb 0.05 mm. ....	3	11.3
Zn 0.10 mm. ....	6	7.1
Al 3.5 mm. ....	200	2.6

“We may conclude from these values that different metals possess transparencies which are by no means equal, even when the product of thickness and density are the same. The transparency increases much more rapidly than this product decreases.”

*Fluorescence and Phosphorescence.*—In his first communication Professor Röntgen discourses at length on the fluorescent effects of the new ray, and states its effect on barium platino-cyanide, calcium sulphide, etc.



The amount and color of the radiations emitted would seem to be entirely dependent upon the character of the substance under examination. In this connection he wrote :

“If the discharge of a fairly large induction coil be made to pass through a Hittorf vacuum-tube, or through a Lenard tube, a Crookes tube, or other similar apparatus which has been sufficiently exhausted, the tube being covered with thin, black card-board which fits it with tolerable closeness, and if the whole apparatus be placed in a completely darkened room, there is observed at each discharge a bright illumination of a paper screen covered with barium platino-cyanide, placed in the vicinity of the induction coil, the fluorescence thus produced being entirely independent of the fact whether the coated or the plain surface is turned toward the discharge tube. This fluorescence is visible even when the paper screen is at a distance of two metres from the apparatus. It is easy to prove that the cause of the fluorescence proceeds from the discharge apparatus, and not from any other point in the conducting circuit.

“The most striking feature of this phenomenon is the fact that an active agent here passes through a black card-board envelope, which is opaque to the visible and the ultra-violet rays of the sun or the electric arc; an agent, too, which has the power of producing active fluorescence. Hence we may first investigate the question whether other bodies also possess this property.

“We soon discover that all bodies are transparent to this agent, though in very different degrees. I proceed to give a few examples: Paper is very transparent; behind a bound book of about one thousand pages I saw the fluorescent screen light up brightly, the printer's ink offering scarcely a noticeable hinderance. In the same way the fluorescence appeared behind a double pack of cards; a single card held between the apparatus and the screen behind being almost unnoticeable to the eye. A single sheet of tin-foil is also scarcely perceptible; it is only after several layers have been placed over one another that their shadow is distinctly seen on the screen. Thick blocks of wood are also transparent, pine boards two or three centimetres thick absorbing only slightly. A plate of platinum about fifteen millimetres thick, though it enfeebls the action seriously, did not cause the fluorescence to disappear entirely.

“ \* \* \* \* The fluorescence of barium platino-cyanide is not the only recognizable effect of the X-rays. It should be mentioned that other bodies also fluoresce; such, for instance, as the phosphorescent calcium compounds, then uranium glass, ordinary glass, calcite, rock-salt, and so on.”

*Reflection, Refraction, Polarization, and Interference.*—The earlier efforts made, tended to show that the Röntgen rays defied reflection, but later investigations have conclusively proved that a reflection, similar to



that diffuse reflection obtained from the surface of ground glass, could be demonstrated. It has likewise been shown that reflection is largely dependent on the character of the substance composing the surface. More recently Carmichael, of Lille, succeeded in reflecting X-rays through the agency of steel mirrors. The value of his experiment has not been determined. In his first paper upon the X-rays Professor Röntgen said :

“After I had recognized the transparency of various substances of relatively considerable thickness, I hastened to see how the X-rays behaved on passing through a prism, and to find out whether they were thereby deviated or not.

“Experiments with water and with carbon disulphide enclosed in mica prisms of about  $30^\circ$  refracting angle showed no deviation, either with the fluorescent screen or on the photographic plate. For purposes of comparison, the deviation of rays of ordinary light under the same conditions was observed ; and it was noted that in this case the deviated images fell on the plate about 10 or 20 millimetres distant from the direct image. By means of prisms made of hard rubber and aluminium, also of about  $30^\circ$  refracting angle, I have obtained images on the photographic plate in which some small deviation may perhaps be recognized. However, the fact is quite uncertain ; the deviation, if it does exist, being so small that in any case the refractive index of the X-rays in the substances named cannot be more than 1.05 at the most. With the fluorescent screen I was also unable to observe any deviation.

“Up to the present time experiments with prisms of denser metals have given no definite results, owing to their feeble transparency and the consequently diminished intensity of the transmitted rays.

“With reference to the general conditions here involved on the one hand, and on the other to the importance of the question whether the X-rays can be refracted or not on passing from one medium into another, it is most fortunate that this subject may be investigated in still another way than with the aid of prisms. Finely divided bodies in sufficiently thick layers scatter the incident light and allow only a little of it to pass, owing to reflection and refraction ; so that if powders are as transparent to X-rays as the same substances are in mass—equal amounts of material being presupposed—it follows at once that neither refraction nor regular reflection takes place to any sensible degree. Experiments were tried with finely powdered rock salt, with fine electrolytic silver powder, and with zinc dust, such as is used in chemical investigations. In all these cases no difference was detected between the transparency of the powders and that of the substance in mass, either by observation with the fluorescent screen or with the photographic plate.

“From what has now been said it is obvious that the X-rays cannot be concentrated by lenses ; neither a large lens of hard rubber nor a glass

lens having any influence upon them. The shadow-picture of a round rod is darker in the middle than at the edge; while the image of a tube which is filled with a substance more transparent than its own material is lighter at the middle than at the edge.

“The question as to the *reflection* of the X-rays may be regarded as settled, by the experiments mentioned in the preceding paragraph, in favor of the view that no noticeable regular reflection of the rays takes place from any of the substances examined. Other experiments, which I here omit, lead to the same conclusion.

“ \* \* \* \* If we compare this fact with the observation already mentioned, that powders are as transparent as coherent masses, and with the further fact that bodies with rough surfaces behave like polished bodies with reference to the passage of the X-rays, as shown also in the last experiment, we are led to the conclusion already stated that regular reflection does not take place, but that bodies behave toward the X-rays as turbid media do toward light.

“Since, moreover, I could detect no evidence of refraction of these rays in passing from one medium to another, it would seem that X-rays move with the same velocity in all substances; and, further, that this speed is the same in the medium which is present everywhere in space and in which the particles of matter are imbedded. These particles hinder the propagation of the X-rays, the effect being greater, in general, the more dense the substance concerned.

“Accordingly it might be possible that the arrangement of particles in the substance exercised an influence on its transparency; that, for instance, a piece of calcite might be transparent in different degrees for the same thickness, according as it is traversed in the direction of the axis, or at right angles to it. Experiments, however, on calcite and quartz gave a negative result.”

Sir G. G. Stokes,<sup>1</sup> “The Wild Lecture,” lucidly says: “Everything tends to show that these rays are something which, like rays of light, are propagated in the ether. What, then, is the nature of this process going on in the ether? Some of the properties of the Röntgen rays are very surprising, and very unlike what we would be in the habit of considering with regard to rays of light. One of the most striking things is the facility with which they go through bodies which are utterly opaque to light, such, for example, as black paper, board, and so forth. If that stood alone it would not, perhaps, constitute a very important difference between them and light. A red glass will stop green rays and let red rays through; and just in the same way if the Röntgen rays were of the nature of the ordinary rays of light, it is possible that a substance, although opaque to light, might be transparent

<sup>1</sup> Ibid.

to them. So, as I say, that remarkable property, if it stood alone, would not necessarily constitute any great difference of nature between them and ordinary light.

“ \* \* \* \* But there are other properties which are far more difficult to reconcile with the idea that the Röntgen rays are of the nature of light. There is the absence, or almost complete absence, of refraction and reflection. Another remarkable property of these rays is the extreme sharpness of the shadows which they cast when the source of the rays is made sufficiently narrow. The shadows are far sharper than those produced under similar circumstances by light, because in the case of light the shadows are enlarged as the effect of diffraction. This absence or almost complete absence of diffraction is, then, another circumstance distinguishing these rays from ordinary rays of light. In face of these remarkable differences, those who speculated with regard to the nature of the rays were naturally disposed to look in a direction in which there was some distinct difference from the process which we conceive to go on in the propagation and production of ordinary rays of light. Those who have speculated on the dynamical theory of double refraction have been led to imagine the possible existence in the ether of longitudinal vibrations, as well as those transversal vibrations which we know to constitute light. If we were to suppose that the Röntgen rays are due to longitudinal vibrations, that would constitute such a very great difference of nature between them and the rays of light that a very great difference in properties might reasonably be expected. But assuming that the Röntgen rays are a process which goes on in ether, are the vibrations belonging to them normal or transversal? If we could obtain evidence of the polarization of those rays, that would prove that the vibrations were not normal but transversal. But if we fail to obtain evidence of polarization, that does not at once prove that the vibrations may not after all be transversal, because the properties of these rays are such as to lead us to expect great difficulties in the way of putting in evidence their polarization, if, indeed, they are capable of polarization at all. Some experimentalists have attempted, by means of tourmalines, to obtain evidence of polarization, but the result in general has been negative. Of the two photographic markings that ought to be of unequal intensity on the supposition of polarization, one could not say with certainty that one was darker than the other. Another way of obtaining polarized light is by reflection at the proper angle from glass or other substance; but, unfortunately for the success of such a method, the Röntgen rays refuse to be regularly reflected, except to a very small extent indeed. The authors of the paper to which I have already referred appear to have had some success with the tourmaline. Like others who have worked at the same experiment, they took a tourmaline cut parallel to the axis and put on



top of it two others, also cut parallel to the axis, and of equal thickness, which were placed with their axis parallel and perpendicular respectively to that of the under tourmaline.

“But they supplemented this method by a device which is not explained in the paper itself, although a memoir is referred to in which the explanation is to be found—at least of those who can read the Russian language, which, unfortunately, I cannot. I can, therefore, only guess what the method was. It is something depending upon the superposition of sensitive photographic films. I suspect they had several photographic films superposed, took the photographs on these, and then took them asunder for development, and after development put them together again, as they had been originally. They consider that they have succeeded in obtaining evidence of a certain amount of polarization. If we assume that evidence undoubted, it decides the question at once. But as the experiment, as made in this way, is rather a delicate one, it is important for the evidence that we should consider well what we may call the Becquerel rays. I shall say merely that they appear to be intermediate in their properties between the Röntgen rays and rays of ordinary light. The Becquerel rays undoubtedly admit of polarization, and the evidence appears on the whole pretty conclusive that the Röntgen rays, like rays of ordinary light, are due to transversal, and not to longitudinal vibrations.

“It remains to be explained, if we can explain it, wherein lies the difference between the nature of the Röntgen rays and the rays of ordinary light which accounts for the strange and remarkable difference in the properties of the two. I may mention that, although Cauchy and Neumann, and some others who have written on the dynamical theory of double refraction, have been led to the contemplation of normal vibrations, Green has put forward what seems to me a very strong argument against the existence of normal vibrations in the case of light. The argument Green used always weighed strongly with me against the supposition that the Röntgen rays were due to longitudinal vibrations; and the experiments by which, as I conceive, the possibility of their polarization has now been established so completely in the same direction, showing that they are due, assuming them to be some process going on in the ether, to a transversal disturbance of some kind.”

*Chemical and Photographic Effects.*—One of the peculiar properties possessed by the X-rays is that they produce a chemical action upon the haloids of silver, but have very little activity in other reactions. Dixon<sup>1</sup> asserts that these rays affect no combination between CO and O<sub>2</sub>. With such combinations as argentic nitrate in alcohol or HgCl<sub>2</sub> in ammonium oxalate solution, the influence of the Röntgen rays is extremely feeble.

<sup>1</sup>Trans. Chem. Soc., 1896.

The following law has been formulated by Vandevyver.<sup>1</sup> The action of the rays on a sensitive film varies inversely as the distance between them, instead of inversely as the square of the distance.

*Physiological Effects.*—The physiological action of the X-rays will be dealt with at length, in the chapter devoted to X-ray therapy.

*Theories.*—The nature and origin of the Röntgen rays is as little understood to-day as when first discovered. Many and varying theories have been propounded; principal among these may be cited the views put forth by Röntgen, Crookes, J. J. Thomson, Stokes, etc.

Below are tabulated the theories advanced by scientists regarding the probable nature of these rays.<sup>2</sup>

- |   |   |
|---|---|
| 1. Solid particles.                       | $\left\{ \begin{array}{l} \text{Leray. Tesla.} \\ \text{Salvioni, Att. d. Perug., 8, 1 and 2.} \end{array} \right.$ |
| 2. Ether wind.                            |   |
| 3. Ether vortices.                        | Michelson, Amer. J. Science, p. 312.  |
| 4. Ether waves (actual <i>movement</i> ). |   |
| 5. Electro-magnetic.                      |   |
| Longitudinal.                             | Röntgen, 1895, <i>loc. cit.</i>   |
|   | Boltzmann, J. f. Gasb., 39, p. 71.  |
| With transverse component.                | Jaumann, Wied. Ann., 57, p. 147.  |
| Transverse.                               | (a) Very small. Goldhammer.   |
|   | (b) Short trains. G. G. Stokes.   |
|   | J. J. Thomson.  |
| 6. New phenomenon.                        |   |

### Visibility of the Röntgen Rays.

Prof. E. Dorn<sup>3</sup> asserts most positively that the X-rays are *visible*, opinions to the contrary notwithstanding. In support of his statement, he says that when the back of the anti-cathode is presented to the observer's eye, a faint fluorescence is visible on the screen, whereas, with the tube in the correct position, the eye accustomed to darkness could not detect the smallest action, although the appearance of light was distinctly seen, both before and later. In corroboration, Röntgen himself held an absorbing metal plate, containing a narrow slit, before the eye, when he observed a bright line, either straight or curved in direction, depending on the relative positions of the anode, the slit, and the eye.

### Velocity of Propagation of the X-rays.

R. Blondlot<sup>4</sup> has studied the speed of propagation of X-rays, by the fact that a discharge passes more readily across a spark-gap when under

<sup>1</sup> Jour. de Phys., 1897.

<sup>2</sup> Hyndman on "Radiation."

<sup>3</sup> Archives of the Röntgen Ray, May, 1898, p. 69.

<sup>4</sup> Comptes-rendus, Oct. 27 and Nov. 3, 1902. The Electrician (translation), Nov. 21, 1902.

the influence of the rays than when the latter are not present. He also demonstrated that the X-rays have a definite rate of speed, possessing a velocity comparable to the Hertzian waves. Believing that the rate of propagation of the latter through wire is equal to the velocity of light, Blondlot asserts that the velocity of X-rays, Hertzian waves, and ordinary light waves is equal.

### Velocity of the Röntgen Rays.

E. Marx<sup>1</sup> has succeeded in measuring the velocity of the X-rays, by a method very similar to that of Fizeau's toothed wheels, as used for determining the velocity of light; but in Marx's method the intermittence is inherent in the source and the receiver themselves. Röntgen rays are generated by Hertzian waves, and, as the Röntgen rays are the parent rays of the cathode rays, the latter are only emitted during the negative phase of the Hertzian oscillation, *i. e.* during the intermission. The receiver is an electrode, connected with the same exciting agent and producing secondary cathode rays, under the influence of the incident Röntgen rays, but only when found by them in the negative phase. Now, as the X-rays produce peculiar oscillations in the leads, Marx has overcome this difficulty by employing a method in which the source and receiver are both fed from the same Hertzian oscillating wires, minimizing infinitesimally the oscillations by shifting the bridge.

### Charging Action of the Röntgen Rays.

That the X-rays are capable of charging bodies has been maintained by Righi but denied by others. Hahn's<sup>2</sup> views are fully in accord with those of Righi. The discord that exists is solely due to the masking action of the secondary rays. All bodies acted upon by the X-rays acquire a positive charge; hard rays are most effective in charging, as is also a high atomic weight.

<sup>1</sup> *Physikalische Zeitschrift*, November 9, 1905.

<sup>2</sup> *Annalen der Physik*, No. 11, 1905.



## CHAPTER I

### THE RÖNTGEN RAY APPARATUS AND ITS MANIPULATION.

#### I. The Induction Coil.

##### A. LAWS OF FARADAY, OR THE ELEMENTARY LAWS OF INDUCTION.

THE induction or Ruhmkorff coil is an instrument for converting low voltage into high E. M. F., thus necessarily involving the principles of electro-magnetic induction.

In 1831 Faraday discovered that currents may be induced in a closed circuit by moving magnets near it, or by moving the circuit across the magnetic field. Further investigation showed that a current whose strength is changing may induce a secondary current in a closed circuit near it.

In 1832 Faraday observed that a similar induction of a secondary current occurred when interrupting an existing primary current, and the current produced in the secondary circuit on interruption travels in the same direction as the former. When closing the primary circuit, the secondary current travels in the opposite direction. By rapidly "making" (closing) and "breaking" (interrupting) the primary circuit, there is produced an alternating current in the secondary circuit, which is constantly changing in direction.

The current strength produced by induction in the secondary circuit is dependent upon the following principles :

The greater the ratio in the induction coil between the primary section and the secondary coil, the greater will be the resulting E. M. F. of the induced current in the secondary circuit.

By induction, the greater the E. M. F. in the primary circuit, the greater the increase of current strength in the secondary circuit.

The strength of the induced current will vary with the rapidity with which the iron core is alternately magnetized and demagnetized.

The working capacity of an induction coil depends upon the circumstances that :

The core must be of soft iron that can readily be magnetized or demagnetized by an interrupter in the primary circuit.

The secondary circuit must consist of a great many turns of fine wire, so as not to increase the bulk.

The primary coils carry the current from battery, accumulator, or main, which magnetizes the core of soft iron, thus creating a powerful magnetic field around and through the secondary windings. The interrupter causes the current in the primary circuit to vary rapidly, and the

resulting variations in the intensity of the magnetic field react upon the secondary coil, inducing an electro-motive force in each and every turn of the wire. The "making" of the magnetic field is much more slowly accomplished than its destruction when the current is "broken," thus, the induced electro-motive force in the secondary at "breaking" is by far the greater. The induced secondary current when "making" is greatly below that when "breaking," so that the former is found insufficient in exciting a vacuum tube. Advantage is gained from this phenom-

enon because the induced current at "make" travels in the wrong direction and could not cause the tube to be excited, as it is in the case with the "break" induced current.

The induction of currents in the secondary coil by means of the currents in the primary coil may be more readily understood from a consideration of Fig. 68.

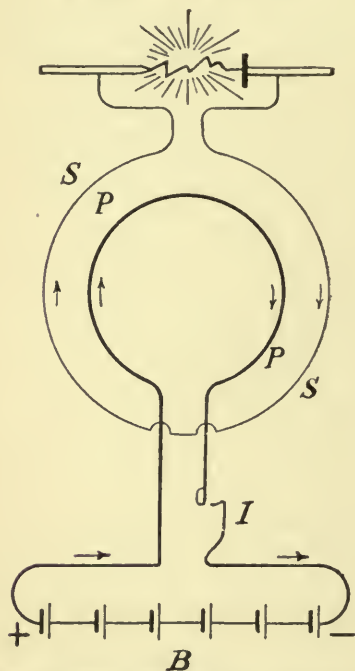

FIG. 68.—Diagram illustrating the principles of induction. (After Donath.)

The battery "B" will cause a current to flow through the primary coil "P" when the circuit is closed by the interrupter "I;" but the current does not instantly assume its maximum value. It takes an appreciable time to rise to the current value set by the resistance of the circuit. This gradual rise of the current is due to the presence of the self induction of the circuit,

the largest percentage of which exists in the primary coil. During the time that this self-induction current is rising in the primary circuit, a magnetic field is being established about the primary winding. The strength of this magnetic field is at all times directly proportional to the primary current. It is, therefore, zero at the time that no current flows, and a maximum when the current has stopped rising. This magnetic field embraces the secondary coil as well as the primary. While the primary current is rising and the magnetic field is growing, a voltage is produced in the secondary coil by the expansive lines of magnetic force, which voltage tends to produce a current in the secondary coil opposite in direction to that flowing in the primary.

This current, induced at this time, is of low voltage and is not the current desired in the X-ray tube. It is the "inverse" discharge which tends to blacken the tubes and lower the vacuum at the time of the running of the tube.

When the interrupter opens the primary circuit, the primary current suddenly stops, and at the same time the magnetic field collapses, inducing a very high voltage in the secondary coil. This tends to produce a current in the secondary coil in the same direction as the current flowing in the primary.

## B. THE CONSTRUCTION OF THE INDUCTION COIL.

1. *The Primary Coil.*—The first requirement in the construction of an X-ray induction coil consists in arranging into a cylindrical bundle many equal lengths of finely annealed charcoal iron wire, and in winding around this core, several layers in thickness, a stout insulated (primary) wire so arranged as to have terminals at one end for future connection. Surrounding this cylinder is another cylinder made of some specially selected substance, as ebonite, hard rubber, shellac, or resin, to afford insulation.

2. *The secondary coil* is composed of a great number of windings of very fine wire, to effect the principle that a high E. M. F. is in a great degree dependent upon the number of turns in the secondary coil. The secondary coil is found on the market made up in sections. This allows of the easy replacement of any one section; a source of economy.

The ends of the secondary coil are connected with brass terminals mounted upon the flanges, an ebonite cover or separate stands. The whole finished coil is suitably supported upon a stage of wood with the other necessary appliances.

3. *Condenser.*—The purpose of the condenser is for the sudden and complete demagnetization of the soft iron core—the length of the spark depending upon the abruptness with which the demagnetization is accomplished. Another use of the condenser is to prevent the sparking of the extra current passing between the contact studs of the interrupter. The more recent condensers are made in sections and are provided with an indicating dial, designating how much to increase or decrease the capacity of the condenser, as determined by the size of the primary coil. The condenser is made up of many sheets of tin-foil separated from each other by sheets of paraffin paper, or paper impregnated with resin or plates of mica. The foil is arranged thus: The first, third, and fifth sheets are so connected as to overlap the paper sheets on one side; the same method is applied to the union of the even numbered sheets of the other; these layers are connected with those parts of the interrupter where the "make" and "break" occur. The unit of capacity is the



“micro-farad.” The capacity of condensers used in induction coils varies from one-half M. F. to 12 or 15 M. F., depending upon the size, make of the coil, and the voltage upon which its primary circuit is used.

The *commutator* is an appliance mounted on the base for the support of the coil, and placed at the side of the interrupter. It is a double reversible switch capable of changing the direction of the current in the primary and consequently in the secondary circuit.

### C. INTERRUPTERS.

The interrupter (rheotome) is a device employed by electricians for the purpose of effecting rapidly succeeding induced currents in the secondary coil, by a corresponding rapidity in the opening (“breaking”) and closing (“making”) of the primary coil. Interrupters are divided into the mechanical and the electrolytic, with the following subdivisions:

1. Mechanical.
  - Platinum.
    - Vibrating hammer.
    - Independent.
    - Self-starting.
    - Vril.
  - Mercury.
    - Dipper.
    - Rotary.
      - Disk.
      - Johnston.
      - Jet.
2. Electrolytic.
  - Wehnelt.
  - Caldwell and Simon.

*Platinum.*—The *vibrating hammer* which vibrates in response to the magnetism exerted by the primary coil is little used at present.

The *independent vibrating hammer* is so constructed that a magnet placed in a shunt circuit can vibrate the hammer independently of the coil. The diameter of the contacts should be as large as possible, and the faces absolutely parallel, in order to carry all the current required. The number of interruptions in this hammer is dependent upon the number of weights attached to the vibrating hammer. The greater the number of weights employed, the fewer will be the resulting vibrations.

The *self-starting* (Figs. 69, 70) mechanical interrupter requires little attention from the operator, as he is not called upon to effect the vibrations. This ingenious invention is the work of H. C. Snook and Edwin W. Kelly, of Philadelphia, who aptly say:

“This interrupter is a form of platinum break which is actuated not by the magnetic field of the coil itself, but by an independent electro-

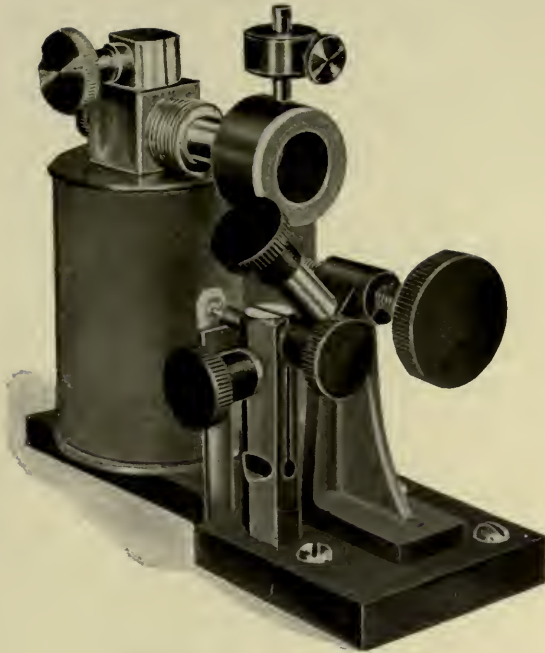

FIG. 69.—Self-starting interrupter.

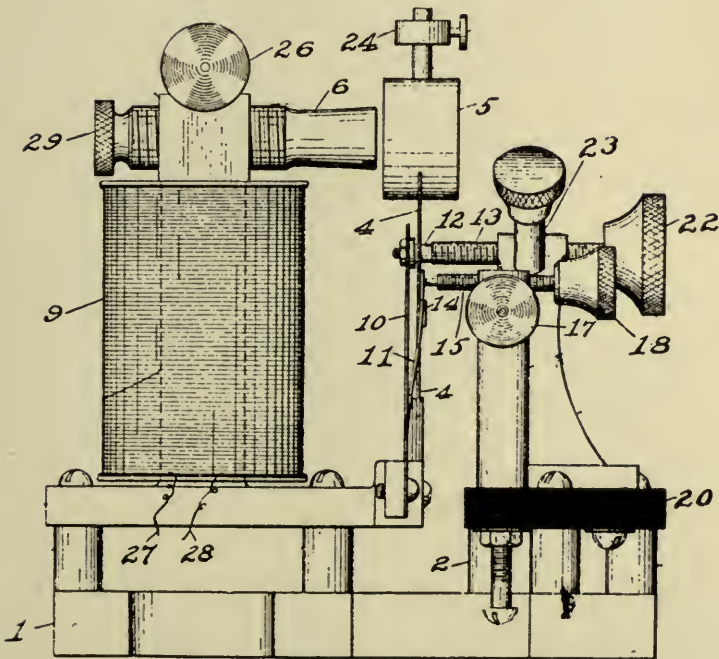

FIG. 70.—Diagrammatic sectional view of the self-starting interrupter.  
(Röntgen Manufacturing Co.)





magnet (9), which is in series with a small spring (11) and a set of platinum contacts of its own, and is shunted directly across the supply wires.

“The magnetic circuit is so arranged that a very powerful pull is exerted on the armature at the instant of starting from rest. This provides the self-starting feature which has given to the interrupter its name. The break is quite efficient and gives very little trouble.

“This has been accomplished by making the magnetic circuit with a minimum amount of reluctance, and providing a properly shaped armature and pole piece. The magnetic circuit is completed from the armature to the base of the magnet coil through the interrupter spring itself. By this arrangement the only air gap in the path of the magnetic lines of force is that between the pole piece and the armature itself, making the tractive force exerted on the armature a maximum for the magnetizing current employed.”

The “*vril*” interrupter is an old type of the spring platinum variety. It is rapidly passing into disuse, but it possesses the great advantage of being capable of generating a high E. M. F. in the secondary coil. Sparking is unavoidable, and its occurrence constantly menaces the integrity of the platinum stud.

To obviate this difficulty the elasticity of the spring is no longer taken advantage of, but in its place a light piece of flat metal, balanced on its edge, is substituted for the movable contact.

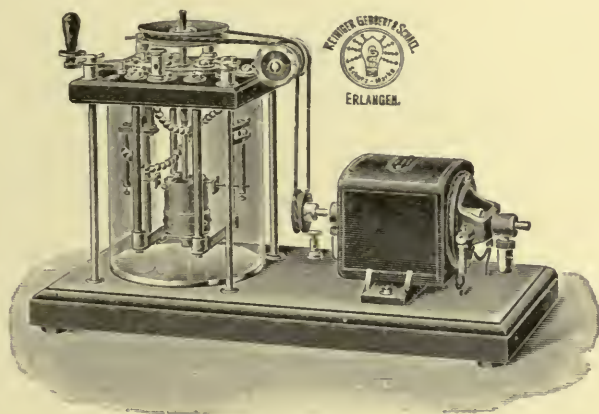

FIG. 71.—Mercury interrupter.

*Mercury.*—Mercury interrupters are of two kinds—the *dipper* and the *rotary*. In the dipper variety an electro-motor (Fig. 71) is employed to effect the “dip,” and likewise the withdrawal of a platinum-tipped rod from contact with the mercury for the greater part of each cycle; it is out of the mercury for a relatively short period, because the current is not

generated at the moment of contact. In this form of interrupter the surface of the mercury is covered with a layer of alcohol, water, or petroleum, in order to decrease the oxidation resulting from "sparking." This form of "break" is cumbersome, being mounted on a separate base. Instead of being worked by the core of the coil, this interrupter may be brought into action by employing a small motor. One precaution, however, with the latter method is necessary. If the breaks are not started prior to the turning on of the current into the coil, the coil may suffer serious damage by the heavy influx of current upon closing the circuit, should the dipper be immersed in the mercury.

*Davidson's Rotary Contact Breaker.*—Dr. Mackenzie Davidson's interrupter<sup>1</sup> (Fig. 72) consists of a vane mounted at the end of a spindle driven by a small motor. As the latter rotates, the vane makes and breaks contact with the mercury contained in a trough or box, on the cover of which the motor is mounted. The motor and spindle are placed at an angle of about 30° so that the spindle passes down through a hole in the lid. The mercury is thus closed in, and splashing is prevented. The break is found to work well with electro-motive force up to 100 volts.

The *disk* interrupter, a subdivision of the rotary, is included in that class of "breaks" in which the contacts are separated by the revolutions of a disk effected through the agency of an electro-motor. The contacts and disks are immersed in alcohol or petroleum, to prevent the likelihood of sparking.

*The Johnston Mercury Interrupter.*—Dr. Geo. C. Johnston, of Pittsburg, exhibited before the American Röntgen Ray Society in Baltimore, 1905, a new form of mercury interrupter (Fig. 73) for which he claims special features. There is no oxidation of mercury, no sticking, uniformity of discharge, absolute control of speed and current, it will not explode, it occupies little space, makes little noise, and will run for months with little attention. He describes the Johnston mercury interrupter as follows: "The interrupter consists of an inclined shaft at the lower end of which is a peculiar shaped blade, alternately dipping into a pool of mercury. This shaft is rotated by means of a motor to which a speed control is attached. The containing case is of heavy cast iron, and the top is screwed down and insulated from the case with a thick rubber gasket and insulated bushings. One end of the box is inclined toward the mercury pool and arranged with grooves, so that when the mercury is thrown to the top of this incline by the action of the blade, in running back into the pool, it travels slowly over a considerable section of the cast iron and leaves any impurities that it might have contained in them.

"The box is arranged to be air-tight, and the pet cock is fastened in the lid, by means of which the mercury or any other liquid can be

<sup>1</sup> Archives of the Röntgen Ray, Jan., 1901.

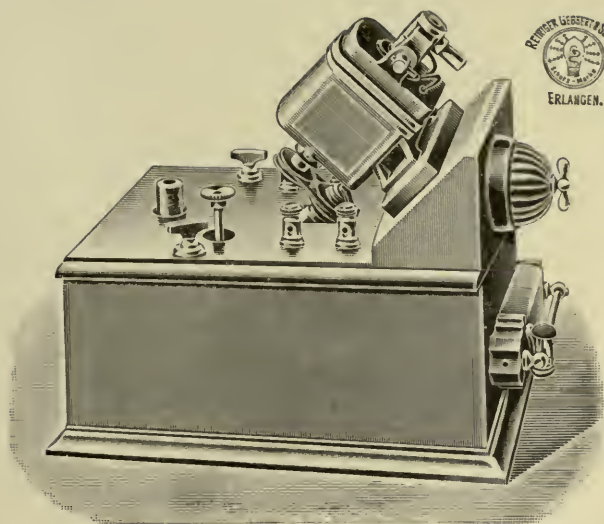

FIG. 72.—Davidson's interrupter.



FIG. 73.—Johnston's mercury interrupter.





poured into the interior. It has been found that when the proper amount of mercury is placed in the pool and a few drops of wood alcohol added, after the first slight explosion takes place, the interrupter will run along without any sparking, and consequent oxidation of the mercury, and break currents of considerable magnitude, as much as 40 or 50 amperes. The quality of the spark obtained from the secondary of an induction coil with this amount of current flowing through its primary, is surprisingly thick and heavy, and the discharge is of exactly the right quality to produce the results in radiography. When the alcohol explodes in the box, there is a slight pressure produced, which is retained, owing to the air-tight quality of the box, and the interrupter will run along indefinitely with absolutely no attention. If any irregularity of the secondary sparking is noticed, all that is necessary to do is to open the pet cock, pour in an ounce or so of mercury and a dozen or fifteen drops of wood alcohol, close the pet cock, and the interrupter is ready for use again. This interrupter will run for a long time without interior cleaning, which can be readily accomplished without taking apart, by unscrewing a plug in the bottom of the box, letting the mercury drain out, and filling the box with water and giving it two or three vigorous shakings. After draining the water out, the plug is replaced tightly, and some fresh mercury added, when it is ready for another three or four months' use."

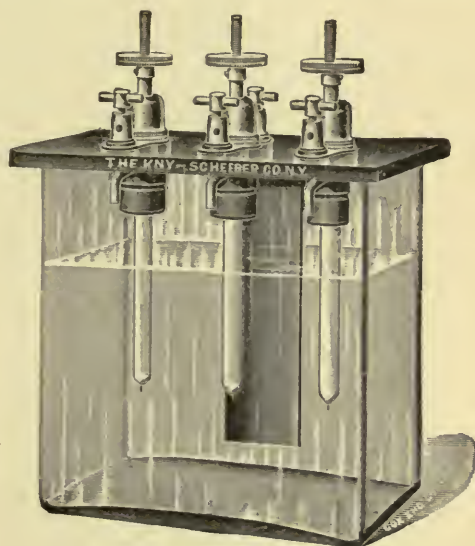

FIG. 74.—Wehnelt interrupter.

In the *jet* interrupter, a jet of mercury impinges upon a rotating metallic surface. The jet carries the current, and the length of contact can be regulated according to the operator's demands by elevating or lowering the contact plate relatively to the jet. The break is instantaneous and complete.

The *electrolytic interrupters* are subdivided as follows: *Wehnelt* and the *Caldwell and Simon*.

This type of interrupter depends upon the formation of gas bubbles at the poles of an electrolytic cell.

The *electrolytic "break" of Wehnelt* (Fig. 74), the most rapid of all

interrupters, consists of a jar holding the electrolyte (dilute sulphuric acid s. g. 1016 to 1020), a plate of lead (the cathode), and a piece of platinum insulated except at its extremity (the anode).<sup>1</sup>

The greater the quantity of sulphuric acid employed, the greater the current and the better the conductor. A steady electro-motive force of at least 24 volts is applied to the interrupter, arranged in series with the primary circuit of the coil. Should the platinum not constitute the anode, the interruptions will not be sharp and regular. Under these conditions the platinum is very rapidly consumed.

One of the advantages of this interrupter is that either a continuous or alternating current can be employed. It likewise obviates the use of

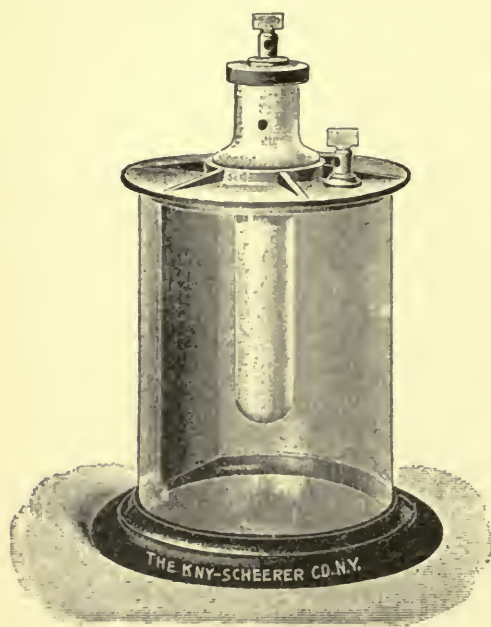

FIG. 75.—Simon interrupter.

the condenser, and in many instances the rheostat. Another advantage is, that it allows tremendous amounts of amperage to pass to the primary coil, averaging anywhere from fifteen to forty amperes.

The number of interruptions in this break varies from 1000 to 40,000 per minute, and is dependent upon the size of the exposed portion of the platinum point. This can be regulated by presenting a larger surface either by means of a screwing device, or by several thicknesses of these points in the same electrolyte. The rate of interruption can be gauged by the tuning-fork; or as the result of experience, the operator recognizing a peculiar humming, musical note.

A recent device, added to this instrument, is a spiral leaden tube, which acts as the cathode, and as the sulphuric acid (electrolyte) becomes warm the interruptions cease to be regular, and water from a faucet is passed through the tubing in order to cool the electrolyte.

In the *film* variety of the Wehnelt interrupter, the interruptions are brought about by the production of a non-conducting film of vapor or gas around the anode. The effects produced are, in a measure, proportionate

<sup>1</sup> In 1899 Wehnelt, of Charlottenburg, first applied the above principles to the satisfactory working of the X-ray coil.



to the thickness of the wire, so that the employment of three or more wires of different gauges is often expedient. Most advantage is gained with an E. M. F. of 50 to 120 volts. The voltage is regulated by means of a rheostat. For short runs a voltage of 40 to 100 volts is all that is required, but its employment must be for a brief interval only. To continue for a half hour or an hour would cause the generation of great heat in the acid,

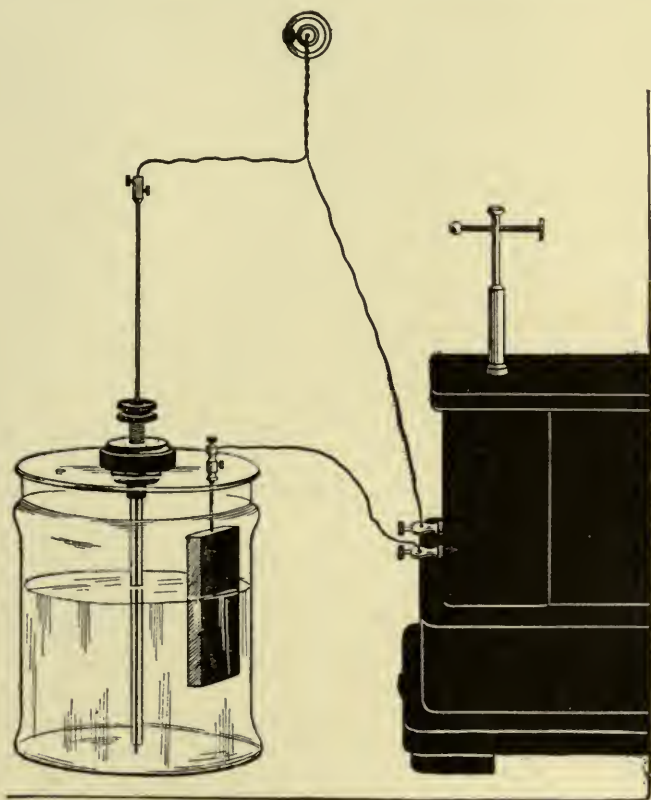

FIG. 76.—Fricklander electrolytic interrupter. The electrolyte is composed of a 10 per cent. solution of magnesium sulphate, and the anode is made of German-silver wire. The operator can control the current for the work in hand by simply turning the thumb-screw. It operates by either the direct or alternating currents.

with a stoppage of the mechanism. To avoid this drawback, many devices have been employed. Among the most important are the use of the sulphates of magnesia and potash-alum in place of the acidulated solution, and also by making the container larger, and through it maintaining a flow of cold water. This type of interrupter is easily managed; its most pronounced disadvantage is its constant humming sound, while its very high E. M. F. has a tendency to disturb the vacuum of the Crookes tube.

There are very many varieties of the electrolytic interrupter, numerous modifications of the Wehnelt, bearing various names.

*Caldwell and Simon.*—In 1899 Mr. E. W. Caldwell, of New York, and Dr. H. T. Simon, of Berlin, simultaneously and independently of each other, had published the description of a new type of electrolytic interrupter, the principle involved being the production of interruptions by the vaporization of the electrolyte at the aperture connecting the two chambers. The apparatus consists of a glass jar containing dilute sulphuric acid, with two plates of lead, one for the anode and the other for the cathode. A partition of glass or porcelain, containing a hole, separates these two plates and at the same time allows the communication of the liquids in the two portions of the cell. The frequency of the interruptions is dependent upon the strength of the current, the size of the aperture, the resistance offered by the electrolyte, and to some extent upon the inductance of the circuit. A pointed rod, non-conducting in nature, regulates the number of interruptions by increasing or decreasing the calibre of the aperture. The electrolytic action results in the generation of bubbles of gas (steam), which break the circuit; these bubbles are almost instantaneously dissipated and then renewed, their frequency being somewhat dependent upon the size of the aperture. More recently the septum between the two containers has been made of perforated porcelain disks, in order to prevent the damage incident to the inner tube, from the unequal expansion of the glass of which it was formerly made.

Dr. Simon claims that the advantage of his interrupter (Fig. 75) over the Wehnelt is to be found in its being independent of the current direction, working equally as well with the alternating as with the continuous current; because in the Caldwell-Simon interrupter, the watery vapor is periodically evolved and followed each time by condensation, and thus the current is alternately made and broken.

A useful electrolytic interrupter is shown in Fig. 76.

#### D. VARIETIES OF INDUCTION COIL.

(a) *Variable Primary Induction Coils.*—Walter, of Hamburg, constructed induction coils with a variable number of sections for the primary, in order to obtain the proper quality in the secondary discharge. This he effected by arranging the windings of the primary coil in a number of sections, and passing the current through a greater or lesser number of these divisions as he required more or less current. Each of the coil windings can be connected in series, in two groups, or in parallel. These windings end in wires to form contacts at one side of the primary coil. Upon these contacts are placed pins which support plugs, and so arranged as to effect the desired connection between the terminals of the coil

endings. By connecting the windings in series (for soft tubes), the self induction of the primary coil is much augmented. By connecting in parallel (for hard tubes), or in two groups (for tubes of medium density), self induction is materially decreased.

The primary coil is covered with an insulator of glass, ebonite, paraffin, etc. This coil is frequently manufactured in a varying number of sections or divisions, so that it can be replaced at pleasure within the secondary coil, and be renewed, at any time, thus obviating the unnecessary expense of providing for the cost of the entire coil.

The secondary circuit must be perfectly insulated; lack of this most important provision will result in discharges within the apparatus, fusing the wire and destroying the coil. The insulating material used may be paraffin, varnish, wax, or silk. Whatever substance be used, the several layers of wires which are already of themselves well insulated must be likewise insulated from one another.

A wise expedient in this connection has been the device of employing several short secondary coils in place of a single secondary coil. This artifice insures better insulation, easy repair in the event of short-circuiting, and the lessened cost incident to replacement.

*The Jumbo Coil.*—This coil, owing to its mechanical arrangement, does not throw more than a 9-inch spark (23 cm.), thus making it necessary to insulate only for the voltage equivalent for that spark length. This saves much valuable space, and it is therefore possible to use more iron in the primary core, as well as heavier wire on both primary and secondary, which are also brought into closer proximity to each other. In this way the efficiency is so increased that when running on 110 volts direct current, it will push 50 per cent. more energy through a tube backing up three to four inches parallel spark-gap than any standard 20-inch (50-cm.) coil. (See Fig. 101.)

By means of the variable inductance of the primary, the value of which is changed by moving a switch, it is easy to adjust the voltage delivered by the coil to suit the resistance of the tube being used, so as to force the greatest amount of X-ray producing energy through it.

The switch-board is provided with a voltmeter and ammeter, a switch for making connection for use of either the mechanical or electrolytic interrupter, a condenser-switch used in connection with the mechanical interrupter, a reversing-switch to change the polarity of the discharge, and a regulating rheostat.

The usual method of operation is to connect the tube to the coil, set the inductance switch at point number 6, maximum inductance, connect the interrupter desired, close the reversing-switch so as to allow the current to pass into the primary, and adjust the current by means of the regulating rheostat.



If the tube does not light up properly, the current is thrown off, the inductance switch changed, and the tube excited again. This adjustment is very simple, and the proper inductance for any tube for skiagraphy or for X-ray therapy is readily obtained.

(b) *Tesla Coil*.—The Tesla coil became universally known when Röntgen's discovery was first verified throughout the civilized world. The alternating currents resulting from the action of this device are of exceedingly high frequency (10 to 20 millions per second) as compared with the Ruhmkorff coil with mechanical contact breakers; whilst the induced secondary electro-motive force of the Tesla coil is hundreds of thousands of volts. Comparable to the rapidity of oscillations thus produced, is the discharge of a condenser or Leyden jar. These discharge

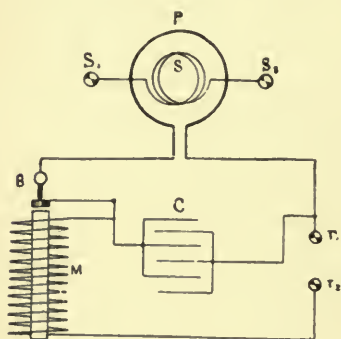

FIG. 77.—The Tesla oscillator.

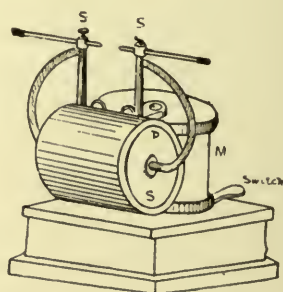

FIG. 78.—Outer view of the same.

currents are made to pass through the primary of an induction coil, devoid of the usual iron core. The primary is made up of a very few turns of thick wire; the secondary has comparatively only a few turns of wire.

So great is the electro-motive force that the average non-conductor would fail to effect insulation; hence the necessity of immersing the whole coil in an oil bath from which only the primary and secondary wires protrude.

For charging the condenser, it becomes necessary to pass the alternating current through a transformer, which raises its pressure to about 6000 volts. The existence of a bright, snappy spark, in the adjustable spark-gap, indicates the discharge of the condenser.

The employment of the Leyden jar is fraught with much danger, if care is not taken to make the primary circuit inaccessible. On the other hand, sparks taken from the secondary of a Tesla coil are innocuous; but the intense and continuous crackling produced by the primary spark-gap is frequently terrifying to nervous patients and children.

*Tesla Oscillator*. (Figs. 77, 78.)—This device consists of three parts: A vertical electro-magnet, well wound very many times with stout wire,

possessing much self-induction. A condenser, which is charged by the self-induction of the electro-magnet on breaking the circuit which discharges into the primary of the horizontal transformer. The latter is composed of a single turn of copper ribbon, about six inches wide, and its secondary consists of one layer of thick wire.

The working of the oscillator is as follows: The current from the terminal,  $T_2$ , magnetizes the electro-magnet,  $M$ , which, in attracting its armature, breaks the circuit at  $B$ , and the high electro-motive force, due to the magnet's self-induction, charges the condenser  $C$ . The discharge being extremely rapid and oscillatory and flowing through the primary,  $P$ , has its voltage increased in the secondary,  $S$ . The rate of vibration should be timed below one hundred per second. The oscillator is, for some unknown reason, not put upon the market. In the laboratory it is found to be inexpensive, compact, and very durable; the absence of any delicate wire and the general construction of the device afford almost indefinite immunity against any disturbance of its insulation; but for skiagraphic work, special tubes are demanded, because of the alternating current generated by the oscillator.

(c) *Kinraide Coil*.—The Kinraide coil, the ingenious invention of Mr. T. B. Kinraide, of Boston, is a special modification of the Tesla coil and possesses many features of merit.<sup>1</sup> Among other things Mr. Kinraide remarks: "The coil I have succeeded in making was the result of the repeated breaking down of the Ruhmkorff coils, ranging from six to eighteen or twenty inches. I have succeeded very well in removing from the apparatus the danger of destruction so common to the ordinary Ruhmkorff coils, etc. My object was to remove the high-potential region of the coil as far as possible from the primary. In my coil this has been done, the low potential region of the single coil being the only part it could come in contact with \* \* \* \* the moment the current is broken, the lines of force collapse and fall inward in the direction of the arrows. (Fig. 79.) In this way the highest potential is produced in the outer terminal of a thin flat spiral secondary, if located in the plane of the arrows, and the low potential at the centre. By that method of winding, as the turns grow longer, the resistance per turn increases, and the tendency of the discharge to pass from one turn to the other increases. If a suitable primary were placed on the outside of this secondary, the reverse would be the case, and hence the tendency to break down would be entirely removed in the section of the secondary. In my coil this is the arrangement adopted, and the lines of force fall away from the centre towards the primary in the direction of the arrows in Fig. 80, producing a very high potential at the centre, and practically very little or

<sup>1</sup>American Electro-Therapeutic Association, held at Buffalo, New York, September 24-26, 1901.

no potential at the outer turns, so that the centre discharges in the proportion of about six inches towards the earth wire whilst the outer terminal discharges about three-fourths of an inch only. To remove all tendency of discharge towards the primary, two of these coils were placed

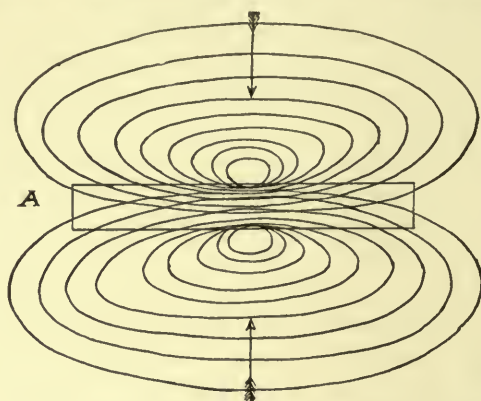

FIG. 79.—Lines of force fall in the arrows in the older form of coil.

side by side (see Fig. 81). The two primaries are so arranged that a high-potential positive and negative is obtained from the centre terminals of the secondaries. There is practically no tendency whatever in this form of coil to break down.”

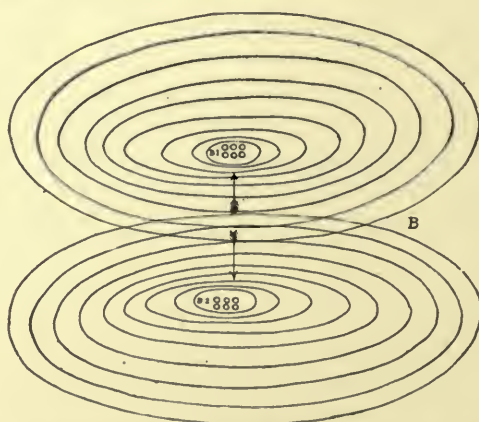

FIG. 80.—Shows the arrangement by which the lines of force fall away from the centre towards the primary, as indicated by the arrows.

In order to present in a clear and terse manner the peculiarities and advantages possessed by this recent invention, it is thought wise to append the following abridged description.

The coil consists of two separate secondaries with their primaries connected in series. Each secondary has a high- and low-potential



terminal, due to the position and the method of winding the primary. The primary is located outside the secondary winding. The secondaries are wound in single flat disks and lie in the same plane as the primaries; with this method of construction the discharge from the two terminals is vastly different. The potential at the central terminal of the secondary is extremely high, while that of the outer turns near the primary is very low. By connecting the outer terminals of two such secondaries in series, the potential of the outer turns entirely disappears, hence there is no tendency to discharge into the primary.

There is absolutely no heating in the primary of the Kinraide coil, as is the case with the Ruhmkorff, so that the insulation cannot be melted, nor is there heat generated where it can in any way affect this delicate part of the apparatus.

A valuable feature is the water-cooled spark-gap. The heat ordinarily developed in various parts of other coils is localized here, where it can be cared for without trouble or risk. In other coils there is a single

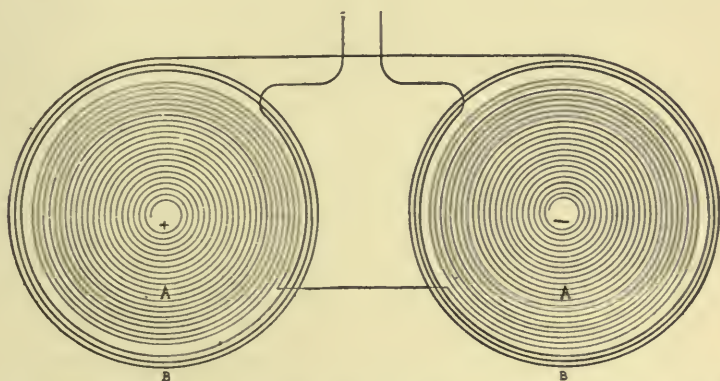

FIG. 81.—Shows the arrangement of two coils side by side: A, A, secondary; B, B, primary.

discharge from every interruption of the primary circuit. With this spark-gap we have a high-frequency apparatus giving many hundred discharges, or surgings, in the secondary for every break or reversal in the primary. This diminishes the time of exposure and increases the steadiness of the illumination of the screen.

The interrupter is solid and durable, and with the spark-gap embodies an entirely new principle, running at constant speed till the motor is stopped. The alternating coil requires no interrupter, but the spark-gap is essential. The use of so little wire in the coil makes the apparatus compact, strong, and portable. The current consumed is about two hundred watts. It may be attached to any incandescent lamp socket, either direct or alternating current.

(d) *Transformer with Closed Magnetic Circuit, for X-rays and High-Frequency Currents.*—Belot, in his admirable work on Radiotherapy, thus describes the above apparatus by Gaiffe & Co., of Paris:

“This new apparatus makes it possible to utilize an ordinary alternating current, without an interrupter, either for the production of X-rays or for high-frequency currents. It consists of an ordinary transformer, with a closed magnetic circuit, receiving an alternating current of 110 volts, which it converts into one of 60,000 volts.

“The current should pass in one direction only. As the alternating current produced by this transformer changes its polarity with each oscillation, one series of waves must be absorbed before reaching the tube. For this purpose two Villard valves are inserted in parallel with the tube in a manner indicated by Villard himself.

“A commutator converts the continuous into an alternating current. This installation is equally adapted for high-frequency work. It is only necessary to remove the Villard valves and insert the spark-gap in order to adjust it for this purpose.”

I have seen Drs. Bécclère in the St. Antoine and Chas. Infroit in the Salpêtrière Hospitals employing this apparatus with satisfactory results.

(e) *Coil without Interrupter.*—Max Levy read a paper before the Röntgen Congress in Berlin on a new form of apparatus in which a high-tension alternating current is utilized without the interposition of any interrupter or condenser. The current is made unidirectional by means of a “strom-spalter,” or current-sifter,—*i. e.*, a pair of spark-gaps, by means of which one phase of the alternating current is conducted to the earth while the other is used for driving the focus-tube. The author expressed the opinion that within the next few years we shall see the total abolition of interrupters for high-tension currents. I have seen the Crookes tube well lighted up in his laboratory in Berlin.

*Transformers.*—Koeh and Sterzel, of Dresden, exhibited before the Berlin Röntgen Congress, a transformer, by means of which a constant current is transformed into an alternating current through the agency of a dynamo, which drives the secondary current-rectifier on the same spindle, thus insuring synchronism. A step-up transformer with closed magnetic circuit is used.

*The Grisson Resonator.*<sup>1</sup>—This is a device for dispensing with the use of an interrupter, and thus doing away with the “make” current, which is so destructive to the focus-tubes. A condenser of large capacity is fitted with a commutator, and so arranged that it is charged alternately to a positive and negative potential. This is connected to the primary of an induction coil, whose self-induction is so adjusted to the capacity of the condenser that resonance is obtained. When this is connected to a

<sup>1</sup> Archives of the Röntgen Ray, April, 1906, p. 308.

source of constant current, unidirectional impulses pass through the primary, and these are transformed in the secondary to the necessary tension required for working the focus-tube.

Since at the end of each discharge the potential of the condenser falls to zero, there will be no spark when the commutator is reversed. We are therefore able to use a simple mechanical commutator, consisting of a massive copper collector, with two rotating rings connecting its plates. The current is conducted to these rings by means of contact brushes. This commutator is rapidly rotated by an electro-motor. The primary of the induction coil is introduced between the electric source and this commutator. When the circuit is first closed there is a sudden rush of electricity through the coil, the current instantaneously attaining a maximum value. As the condenser becomes charged, the intensity of the current gradually decreases to zero. When this has occurred the commutator will break the circuit without any sparking (since there is no current). As the commutator makes contact again with the opposite plate of the condenser, there will be another sudden rise to the maximum current, followed by a gradual fall to zero, as this plate now becomes charged to the potential of the source. The contact is again broken after the current has fallen to zero. The primary of the induction coil is thus traversed by a series of unidirectional impulses, each of which rapidly attains a maximum value, and then very gradually falls to zero—the ideal form of current for obtaining a practically unidirectional current in the secondary. A point of interest is that it is the “make” current which is utilized in this apparatus, whilst the “break” is suppressed; whereas in the ordinary coil our efforts have been directed to suppressing the “make,” and utilizing the “break” current.

## II. Electrical Discharges in Partial Vacua and the Crookes Vacuum Tube.

Before taking up a consideration of the Crookes vacuum tube, it is well to observe that in a low-vacuum tube (Fig. 82) there is a column of luminescence at the positive pole and extending toward the cathode which is separated by a dark space (an interval in the illustration) designated *the dark space of Faraday*. In Fig. 83 the magnet, AB, shows the deflection of the rays. As the pressure decreases, the luminosity increases in volume, and as the pressure becomes still smaller, the luminosity entirely disappears; on the other hand, as the vacuum increases, there is a marked production of the cathode rays as shown in Fig. 84. The deflection of the cathode rays is represented in Fig. 85. In Fig. 86, the employment of one concave cathode in the presence of a number of anodes is shown. As the vacuum is gradually increased, the base of the cathodic cone becomes successively narrower as depicted in 2 and 3.



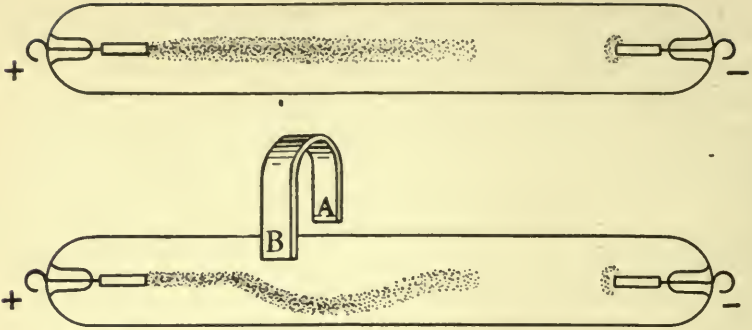

FIGS. 82, 83.—Discharge passing through low-vacuum tubes. (Bouchard.)

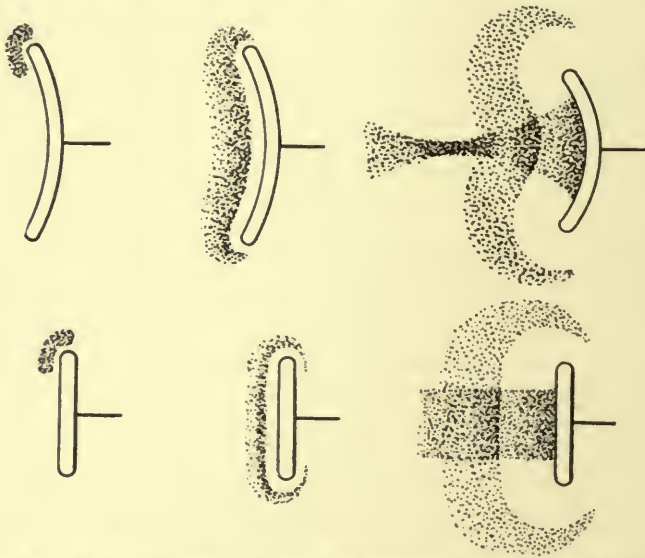

FIG. 84.—Cathode rays. The upper row are concave cathodes; the lower rows are flat. Viewing from left to right, is shown the progressive increase in the production of the cathode rays as the pressure is gradually decreased. (Bouchard.)

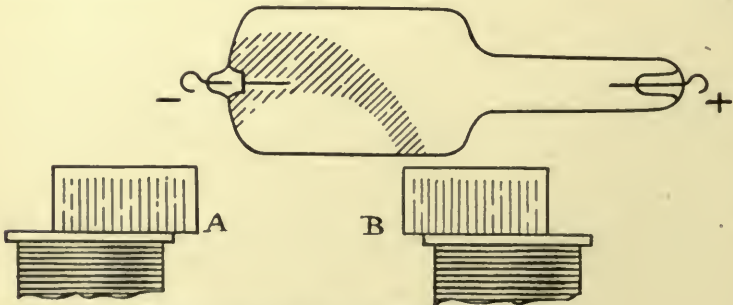

FIG. 85.—Deflection of the cathode rays. (Bouchard.)

The rectilinear propagation of the cathode rays is represented in Fig. 87, where the cathode C throws the shadow of the mica cross A on the wall of the tube A'. Around the shadow  $\Delta'$  the tube shows a pronounced phosphorescence.

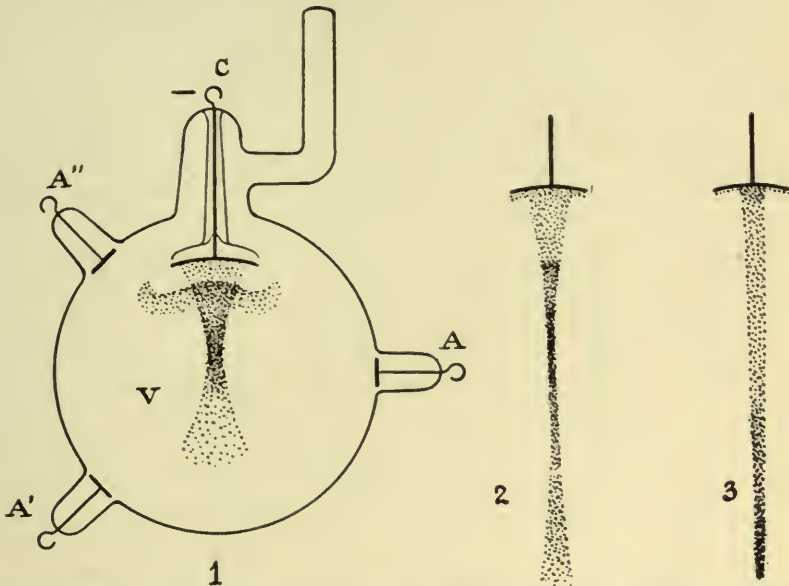

FIG. 86.—Illustrating the effect of one cathode and several anodes under different degrees of vacuum. (Boucharde.)

A Crookes vacuum tube is an apparatus wherein electrical energy is transformed into X-rays. These tubes present various shapes and modifications, according to the requirements demanded. The essential in

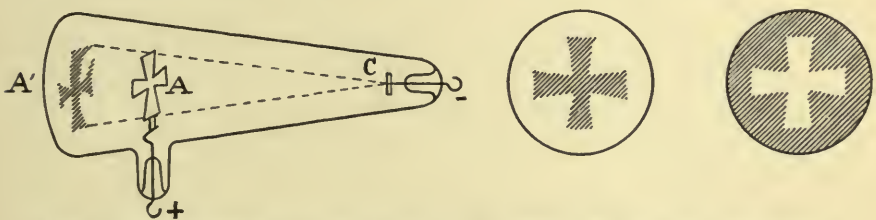

FIG. 87.—Illustrating one of the phenomena in high vacua,—the rectilinear propagation of the cathode rays. (Boucharde.)

the design of an X-ray tube includes a cathode of such shape as to focus the cathode rays on a plate of dense metal, such as platinum, which either is the anode or is placed near to it.

Fig. 88 is the illustration of such a tube. The cathode rays represented by the shaded area focus at a point on the anode, and at this point

the X-rays originate, and from it radiate in every direction in straight lines as light rays do from a source of light. They are represented by broken lines. As platinum is not transparent to them, they are found only on one side on the plane of the platinum and are practically of equal intensity throughout that zone. If the platinum plate were absolutely true and polished such would be strictly the case. As it is, in practice, the rays are of equal intensity down to about ten degrees from the plane of the platinum. In the majority of cases they are made of German soda-flint glass, which presents an apple-green color, due to the fluorescence produced by the X-rays under vacuum, this glass being extremely

transparent to the X-rays. Tubes made of soft lead-glass give a pale blue fluorescence, the lead acting as a barrier to the passage of the rays, hence this kind of glass is not so desirable. Other varieties of glass fluoresce in different colors.

The tube consists of a glass bulb containing a single platinum-faced target and one or more aluminium-faced cathodes.

The anodes and cathodes are connected to outside terminals by means of platinum wires which are encased by the extended glass stems, the latter being fused during the process of blowing. Often tubes are provided with an auxiliary anode, which is invariably made of aluminium.

In order that the shadow-picture may be sharply defined, the cathode rays must converge or be focused to

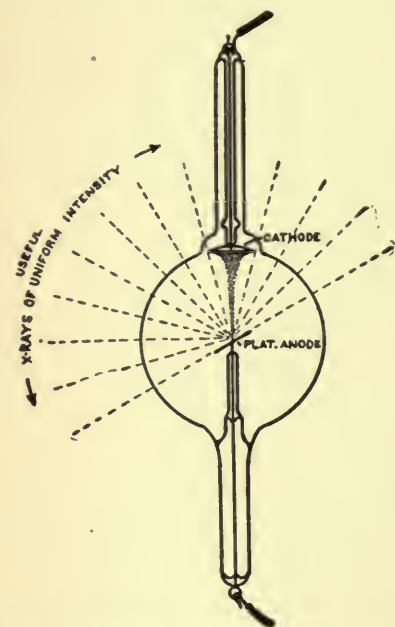

FIG. 88.—Essential features of an X-ray tube.

a point, and to meet this requirement the aluminium cathode must present a concave surface, varying in diameter from  $\frac{1}{4}$  to 1 inch (.5–2.5 cm.). The anode (anti-cathode) is made of platinum, and may have a varying diameter, but it is usual to have its plane so adjusted as to form an angle of 45 degrees to the cathode. Placed in this position the anode behaves like a reflector, receiving and throwing off the rays emitted from the cathode. Platinum has a high fusing point, and it is superior in this respect to all ordinary metals; its use as the target for the cathode bombardment is because of its infusibility. Very few other metals may be used in its place. The most important of these substitutes is iridium, which is another member of the platinum group and has a higher



fusion point than platinum itself. Osmium, which is also an infusible metal of the same group, might be used.

Alloys of these metals, having varying percentages, are also used.

These infusible metals are to be backed up by ordinary metals such as copper and iron, because the latter are less expensive and readily provide a large radiating surface and thermal capacity for the dissipation of the heat produced at the focus-point.

The cathode is made of aluminium, because this metal disintegrates least and causes the least discoloration on the walls of the tube. The Crookes tube contains a very high vacuum,—one millionth degree of atmospheric pressure. In order to exhaust these tubes approximately they are subjected to the action of mercury pumps. When a sufficient vacuum has been obtained, the small glass tube that projects from, and forms part of, the Crookes tube is removed from the pump receiver, by melting it off and sealing it with the aid of the Bunsen burner.

#### A. THE VARIETIES OR TYPES OF VACUUM TUBES.

(a) *Stationary Vacuum.*

(b) *Self-Regulating and Regenerative.*

(a) *Stationary Vacuum.*—A tube with a stationary vacuum is one whose vacuum cannot be altered during its period of usefulness. This marks the earliest type. The Crookes tube was originally pyriform or cylindrical, and contained an aluminium cathode within a glass bulb. The cathodal streams were projected on the extreme opposite side of the tube, producing a peculiar fluorescence. In order to focus and subsequently reflect these rays Prof. Herbert Jackson, of King's College, London, introduced the anode (anti-cathode) so as to reflect the cathode rays.<sup>1</sup> To this improved tube he applied the name "focus" tube.<sup>2</sup> The priority of this modification is also claimed by Shallenberger.<sup>3</sup> As the degree of vacuum in this type of tube is liable to vary either from use or disuse, there is a constant danger of its permanent impairment. If the tube be too hard (high vacuum), there is danger of puncture, and impossibility of X-ray production. If the tube be too soft (low vacuum), the rays will lack the required penetrability.

(b) *Self-Regulating and Regenerative.*—In this type of tube the degree of vacuum is changed either automatically or by the operator, thus allowing various modifications in the penetrability of the rays. This can be effected by the action of gases derived from absorbent substances; founded on the principle that certain chemicals,—caustic potash, palladium,

<sup>1</sup> Jackson was the first experimenter to employ a curved cathode.

<sup>2</sup> *Elect. Review*, London, March 13, 1896; the *Scientific American*, April 4, 1896.

<sup>3</sup> *Elect. World*, New York, March 7, 1896.

permanganate of potassium, etc.,—when placed in an auxiliary bulb (low vacuum), liberate gases upon the application of heat and reabsorb them upon cooling.

In 1896, Mr. L. T. Sayen, of Philadelphia, devised a self-regulating tube which has been placed on the market by Queen & Co. Its principles are as follows: A small bulb, containing a chemical giving off vapor when heated and reabsorbing it when cool, is directly connected to the main tube, and surrounded by an auxiliary tube, which is exhausted to a vacuum of low resistance. In the auxiliary tube the cathode is opposite the above mentioned bulb, so that any discharge through it will heat the bulb by the bombardment of the cathode rays. The cathode is connected to an adjustable spark point, the end of which may be swung to any desired distance from the cathode (main) tube. The coil is connected as usual to the main tube, which has been exhausted to a very high vacuum, and consequently has a resistance equal to ten inches or more of air. When it is put in operation the high vacuum of the main tube, and the consequent high resistance, causes the current to take the path of least resistance by the spark point and the auxiliary tube, and to heat the chemical in the small bulb, thereby driving off the vapor which it contains into the main tube. This will continue for a few seconds until a sufficient amount of vapor has been driven into the main tube to permit the current to go through it, which occurs when the vacuum has been reduced, until the resistance of the main tube is equal to that of the spark-gap plus the small resistance of the auxiliary bulb. After this only an occasional spark will jump across the gap to counteract the tendency of the chemical to reabsorb vapor and raise the resistance of the main tube. The tube is thus maintained at a constant vacuum while running. When the current is stopped, the tube returns to its starting condition of high vacuum.

The construction of the tube should be understood before used, and is as follows (Fig. 89): The large bulb "B" contains the main cathode and platinum reflecting plate. The regulating bulb "D" is connected with the main bulb "B." The cathode "C" in the main bulb is composed of hammered aluminium, moulded to an exact curve of such radius that it focuses the cathode stream on the anode "A," which is composed of platinum, and is the point of emission of the X-rays.

Bulb "B" is exhausted to a high vacuum, so that initially no electrical discharge will pass through it. Bulb "D" is exhausted to a low Crookes vacuum.

Within bulb "D" is a small pear-shaped bulb "X," in communication with bulb "B" and containing a chemical capable of giving off vapor when heated and reabsorbing it when cooled. A small cathode in bulb "D" is arranged so that the discharge will heat this bulb "X."

Attached to this cathode is an adjusting spark-point "P," the end of which may be swung to any desired distance from the terminal of the cathode "C."

When put in operation the high-potential secondary current will not initially pass through the bulb "B" on account of its high vacuum, but chooses a path from "K" to "P," through the bulb "D," heating the chemical in the small bulb "X," causing vapor to be given off and reducing the vacuum in the main bulb "B" until finally it becomes sufficiently lowered so that the discharge passes through the bulb "B" entirely, producing X-rays from the plate "A."

Let the spark-point "P" be separated about three (3) inches from terminal "K." Start coil with small current flowing through primary until sparks begin to jump vigorously between "P" and "K." Then

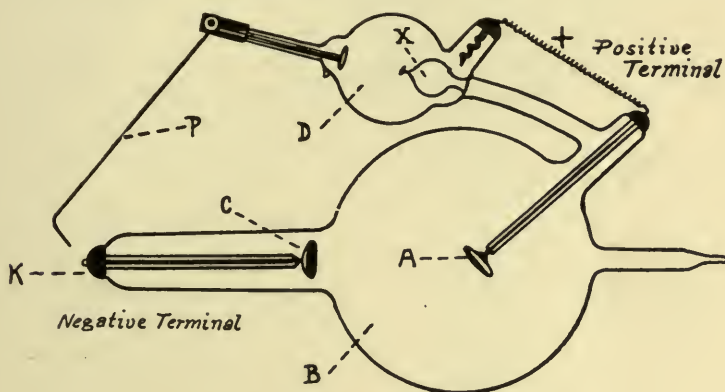

FIG. 89.—Queen's self-regulating tube.

open the primary circuit without changing its adjustment. Immediately close again for a second or so, the spark passing from "P" to "K" through and lighting up the small regulating bulb "D." Continue, alternately, opening and closing the primary circuit, allowing the regulating bulb "X" to heat slowly until a green light begins to show in the main bulb "B." Hold primary circuit open for a second or two, close, and the bulb "B" will then automatically maintain its vacuum at the set point, the primary current may be increased to the full capacity of the tube, while only an occasional spark will pass between "P" and "K." If the bones appear in fluoroscope too black, make the gap between "P" and "K" greater. If not enough distinction between bones and flesh, make less.

When tube is running properly, the main bulb will be filled with a brilliant green light, with a sharp-cut zone through the plane of the platinum plate, the upper section being more brilliant than the lower.



Müller, of Homburg, and E. Dueretet, of Paris, have brought forward a tube, resembling in many respects the Sayen tube, but differing from it in that the regulating discharge passes directly into the auxiliary tube; the latter containing caustic potash. (Fig. 90.) When the vacuum in the main tube becomes too high, and consequently the resistance too great, the current passes into the auxiliary chamber, whereby the potash becomes heated and emits vapor; this vapor diffuses itself through the main tube, thus lessening the too great resistance. Attached to the auxiliary circuit is a lever that regulates the interval of the spark-gap; the more distant the lever from the cathode of the main tube, the higher the vacuum in that tube; the nearer the cathode, the lower the vacuum.

Should the resistance in the main tube be in excess of that of the spark-gap, the current takes the path of lesser resistance and passes

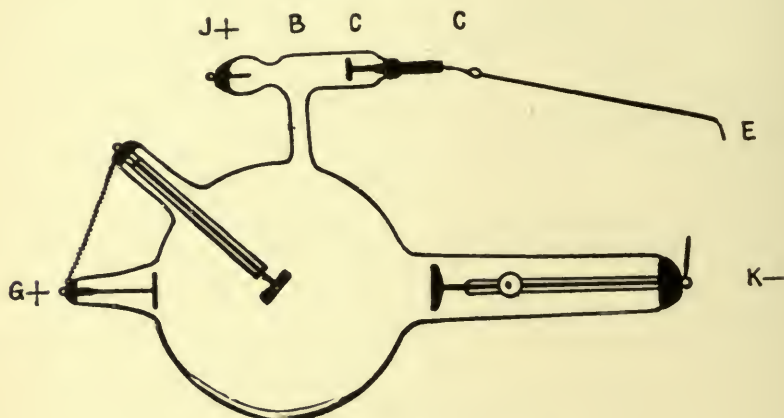

FIG. 90.—Müller's regulation tube.

through the side tube. The presence of sparks in the spark-gap shows that the process is proceeding. Should the vacuum in the main tube become too low (soft), disconnect the wire from the anode of the main tube and attach it to the terminal of the electrode in the auxiliary chamber. The discharge that passes under this adjustment causes metallic particles to be driven against the sides of the tube and the generation of more gas to be occluded on the electrode (auxiliary). Thus the vacuum of the tube may be materially raised.

In order to clarify the above statements, it may be stated that the auxiliary tube "B" contains an electrode, "C," of a substance which will give off a certain quantity of gas by the electric discharge passing through it, and will thus lower the vacuum. This is effected by approaching the wire "E" to the cathode "K" and thus permitting the spark to pass. In case an even degree of hardness is to be maintained, the distance of the

wire "E" from "K" for hard rays (diagrams of the pelvis) is 10–11 cm., for soft rays (diagrams of the hand) 5–7 cm., for treatment even less. The working of the "Müller regulation" may be observed by the sparks passing between "E" and "K." As soon as this stops, the tube has the desired degree of vacuum and will maintain the same *automatically* by an occasional spark jumping over and reducing the vacuum, as soon as the latter shows a tendency to rise. In case the automatic way of lowering the vacuum should require too much time, it can be hastened by either approaching the wire "E" even closer to "K," or finally connecting the negative pole to the loop "C." In this latter event special caution is recommended, as tubes easily become too soft and a hardening is more difficult.

Hardening a tube is effected by changing the positive pole from "G" to "J" and removing the wire "E" far off from "K." When the current is now turned on, it will scatter atoms of the metal of the electrode "J," thus reabsorbing part of the gas of the tube. This process requires up to 5 minutes, according to the vacuum, and may have to be repeated. It is not advisable to change the vacuum of a tube too often. For different purposes different tubes should be employed. Tubes of varying construction have recently been brought forth<sup>1</sup>

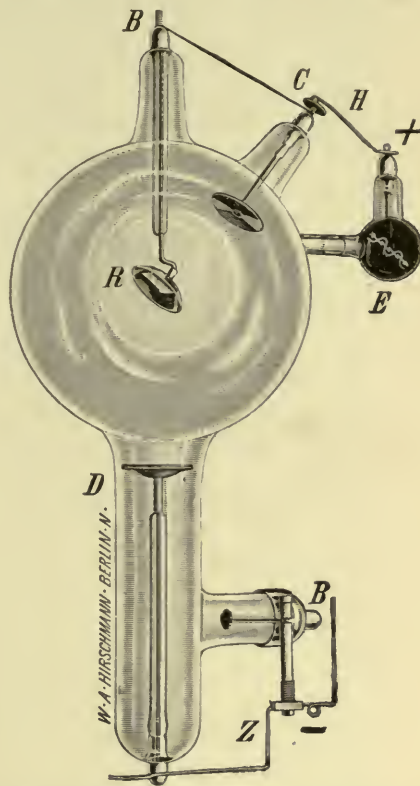

FIG. 91.—Monopol tube. The vacuum may be altered during the process by the generation of air through the disconnection of the movable conductor "Z," or by the absorption of air through the disconnection of the movable conductor "H." The flexible wire "Z" is raised for some seconds by means of an isolated rod until a spark leaps over to the auxiliary cathode at "B," by means of which air is generated and the resistance of the tube lowered. Tubes in which the degree of generation has become excessive are modified by raising the movable conductor "H" as shown in the sketch. Air is generated by the disconnection of the flexible conductor "Z" and the leaping over of sparks to "B," and accordingly the degree of the vacuum in the tube is lowered. Air is absorbed by disconnecting the flexible conductor "H," and the resistance of the tube is increased.

<sup>1</sup> Archives of Physiological Therapy, September and October, 1905.

that are worthy of brief mention. The Monopol tube made by Hirschmann of Berlin is especially devised for easy regulation of the vacuum without interruption of the X-rays. (Fig 91.) Using a spintermeter with ball terminals, he finds that each centimeter of spark equivalent practically corresponds, with this tube, to the same number of the Benoist scale of penetration. It is a bianodal tube, with a separate bulk at the cathode end for lowering, and another at the anode end for raising the vacuum, and either of these may be caused to operate by simply pulling its movable arm with an insulated hook. This may be done while the tube is in operation.

Heinz Bauer has made X-ray tubes in which the rapid raising of the vacuum, due to the pulverization of the platinum anti-cathode is prevented by causing the current to pass mostly to the anode. To this end, the anode is pointed and contains quite a mass of metal; besides this, a regular small self-induction coil is placed between the external connection of the anode and that of the anti-cathode. Another of Bauer's tubes has a heavy corrugated copper stem for the anti-cathode, dissipating heat inside the tube, and also externally, through a reëntrant glass tube which forms a part of it.

*Method by Osmosis.* (Fig. 92.)—This method depends upon the principle that heated platinum possesses the property of being penetrable by hydrogen. A closed tube of platinum is sealed into the bulb of the

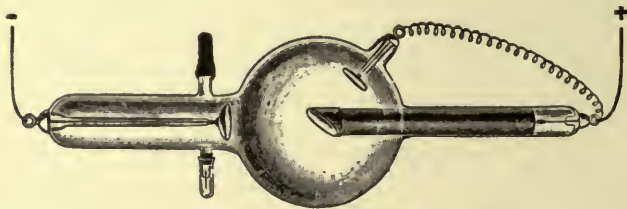

FIG. 92.—Osmosis regulating tube of Gundelach.

X-ray tube. When it is desired to lower the vacuum in the tube, the projecting platinum tip is heated to redness in a Bunsen flame. The heated platinum permits the passage of gas through its pores into the tube, thus lowering the vacuum. This process may be resorted to without interfering with the working of the tube; the degree of vacuum can thus be gauged by the color of the fluorescence. A low vacuum is manifested by a bluish tint, indicating that the heating of the platinum should cease.

*Mechanical Regeneration.*—This method allows of a variance in the penetration value, by adjusting the distance between anode and cathode. Its employment, however, is inapplicable, as it entails the sacrifice of many tubes and requires an adept in manual dexterity.





SELF-REGULATING X-RAY TUBE. OPERATING PROPERLY.

(FIG. 93.)



*Electro-static Regeneration* is founded on the principle that the discharge passing through a focus tube is influenced by the charge generated by electro-static induction on the outer surface of the tube. To accomplish this, the neck of the tube in the plane of the cathode edge is covered with strips of tin-foil, and by connecting it by an adjustable spark-gap with the ground or wire leading to the cathode. The method gives some promise of usefulness, but the serious drawback is, the constant danger of perforation of the tube.

*Water-cooling tubes* are those in which a stream of running water passes around the anode, maintaining it in a cool condition, thus not interfering with the degree of vacuum in the tube. In other tubes there may be two anodes and two cathodes, which are adapted for the use of the alternating current.

## B. THE QUALITY OF THE X-RAYS.

The qualities of the X-rays depend largely upon the apparatus and the degree of vacuum of the Crookes tube. Thus, while the quantity of the electrical energy influences the intensity of the rays produced, the condition of the tube is the predominating factor when a constant and powerful supply of X-rays is required. Tubes are thus said to be "soft," "hard," or "medium."

A tube is said to be "soft" when the degree of vacuum is low, thus offering less resistance and allowing the current to pass easily, but with a diminution in the intensity and likewise in the penetrability of the rays.

In a "hard" tube the degree of vacuum is high, resistance is therefore increased, and a greater obstacle is presented to the passage of the discharge. The radiation gains thereby in intensity, as also does the penetrative power.

The "medium" tube occupies a place intermediate between the "hard" and the "soft."

J. M. Eder and E. Valenta<sup>1</sup> observed that the effectiveness of a tube varied with its degree of vacuum.

Porter<sup>2</sup> thus classifies the rays:

X<sub>1</sub>-rays penetrate the soft parts easily, but the bones with difficulty.

X<sub>2</sub>-rays, those absorbed by the soft tissues.

X<sub>3</sub>-rays, those readily penetrating both soft tissues and bone.

Albers-Schönberg<sup>3</sup> considers four degrees of vacuum:

1, hard (gray).

2, medium soft (gray-black).

3, soft (deep-black).

4, very soft.

<sup>1</sup> Vers. u. d. Photo. mittelst der Röntgenstr., Wien und Halle, 1896, p. 5, Anm.

<sup>2</sup> Quoted by Valenta, Oest. Chemikerztg., I. Nr. I. 1898.

<sup>3</sup> Fortschr. a. d. Geb. d. Röntgenstr., Bd. iii., H. 4, p. 143.



The intensity of the shadows of the metacarpal bones on the fluorescent screen is taken as an index.

Kienböck recognizes a fifth grade, the "over-hard" tube.<sup>1</sup>

The success in skiagraphy most largely depends upon the quality of the rays and the behavior of the focus-tube.

Until the present time, although the form, size, etc., of the tube have steadily improved, the majority of operators will sustain me when I assert that in order to make a good skiagram the knowledge of the degree of the penetration of the rays is most essential.

I have enumerated the various methods for ascertaining the approximate penetrability (quality and quantity) of the rays, but those methods are as yet quite crude. This subject is fully treated of under Röntgen Ray Therapy.

The degree of the vacuum of the tube changes during or after active work, so that the operator cannot predict exactly the degree of penetrability of the rays; hence the time of exposure still remains uncertain.

Testing the rays with the fluoroscope by the shadow of the bones of the hand is most dangerous, and is virtually not employed to-day except by some of the inexperienced and most careless. The osteoscope of Carl Beck substitutes the skeleton hand for the human hand, but this is injurious to the eye, no matter how well the latter is protected with lead (flint) glasses.

Fluorescence of the tube is an inexact measure, and the degree of redness of the anode is unreliable. Each tube behaves differently with different types of interrupters, currents, and coils.

*Spintermeter or Parallel Spark-gap.* — The length of the spark-gap varies with different voltages of current, the shape of the spark-gap, the winding of the coil; the degree of the vacuum of the tube or its resistance cannot be ascertained because of the distance of the anode from cathode, and the varying sizes of the latter may cause more or less resistance.

I have tubes that back up 4 to 5 inches (10 to 12.5 cm.) parallel spark-gap, and yet produce cathode rays bluish in color and conical in shape, which are useless for penetration; therefore the resistance of the tube does not always indicate the penetrability of the rays.<sup>2</sup>

### C. CARE OF THE TUBE.

Before using the tube see that it is absolutely free from dust particles by employing some soft fabric as a wiper, exerting as little pressure on main bulb as possible. The tube should always be perfectly dried by allowing the heat from a gas jet to pass around it.

<sup>1</sup>Wiener klin. Woch., 1900, No. 50.

<sup>2</sup>See Part III., Chapter IV.



SELF-REGULATING X-RAY TUBE. CURRENT RUNNING IN WRONG DIRECTION.

(Fig. 94.)





The leads from the terminals of the secondary coil should be perfectly insulated and sufficiently separated from one another throughout their entire length to prevent any sparking between them. These wires must not come in contact with any conducting material, which would naturally permit of leakage of the current. The conducting wires should be sufficiently distant from the surface of the tube to prevent puncturing. Such a puncture is usually from a spark jumping through the glass wall from the conducting wire to the electrode within the tube of opposite polarity. Puncture of the tube renders it useless, in some cases presenting an immediate change of color. Sparking occurs between the anode and cathode from the inrush of air; in other cases the injured tubes may be worked for two or three hours after the accident. If the auxiliary bulb lights blue or red, the vacuum is low and a puncture or leak may be suspected. (Fig. 97.)

In operating a tube see that the current is sent into it in the proper direction, or blackening will soon occur on the inside, manifesting itself by disintegrating platinum particles. Should the current conductors be connected to the tube in reverse order, the error will be recognized by a brilliant jumping fluorescence around and behind the platinum target. With proper connections there is a steady fluorescence of the hemisphere in front of the anode. As the X-ray apparatus is provided with a commutator, the current can conveniently be reversed without altering the connections and position of the tube. Figs. 93 and 94 illustrate the proper and the wrong connection of the tube.

*Blackening of the Tube.*—As already mentioned, blackening of the tube often results from the "inverse" current, but this can be avoided by placing the spark-gaps in "series" of intervals of two or three inches either in one or both ends of the terminals.

Lately I have seen the whole inner surface of the tube darkened by an impure alkaline substance thrown off from the auxiliary bulb. The tube was opened, and, by the aid of an acidulated solution, the substance causing the discoloration was dissolved, showing that the blackening was not due to disintegrated platinum particles, but to the impurities of the potash in the auxiliary bulb. Had this blackening been caused by the disintegration of the anode, the discoloration would have been manifested only at the active hemisphere.

In place of the spark-gap in "series," Villard urges the employment of a ventril tube with a proper degree of vacuum for the current, instead of its passage through the air. (Fig. 95.) By employing the ventril tube the current becomes unidirectional, the rays have a greater penetrative power, blackening is minimized, and the "life" of the tube is prolonged. I find the self-regulating ventril tube to be eminently satisfactory.

*Puncture of the Anti-cathode.*—This accident occurs only in tubes with very thin and non-supported anodes; especially did puncture of the anti-cathode happen when the Wehnelt interrupter first came into use. This difficulty has been overcome by increasing the thickness of the anode, and also by reinforcing it in back by means of copper; likewise by making the converging cathode rays fall at a point a little in advance of the anode.

*Explosion of the Tube.*—When a tube is accidentally broken, the sudden inrush of air produces a report resembling that accompanying the explosion of a firecracker. I believe the term "explosion" is a misnomer; the substitution of the term "collapse" would appear to me



FIG. 95.—Villard's ventril tube.

to be more correct, for the general breaking up is more likely the result of external atmospheric pressure than due to any force created internally. In the experience of years I have never suffered the explosion of a tube.

The "life" of the tube depends largely on the amount of its use, and the care in manipulation bestowed upon it. The metallization of the tube interferes in no manner with its working.

In regard to the consumption of tubes by the use of small and large inductors the conclusions reached by Albers-Schönberg are of the greatest practical importance. He has kept a complete record of the use of each tube and the conditions under which it was used, and concludes that the life of a tube used with an 80 cm. coil is more than three times as long as when used with a 40 cm. coil. The small coil used in this instance was the Dessauer instrument. At the same time he found that the work done by the tube in connection with the large coil was more satisfactory. In order to get the desired results with the small coil it was necessary to use a ventril tube in series with the Röntgen tube, while with a large coil none was used.

When the vacuum becomes so high or so low (Fig. 96) that it is unsuited for the operator's purpose, and his efforts to restore a proper vacuum are unavailing, the only remedy is a repumping of the tube by the manufacturer.



SELF-REGULATING X-RAY TUBE. LOW VACUUM.  
(Fig. 96.)





### III. The Fluoroscope and Accessories.

#### A. CONSTRUCTION OF THE FLUOROSCOPE.

The fluoroscope, also called cryptoscope and iristoscope, was devised and first described by Professor Salvini, of Rome.<sup>1</sup> It consists of a darkened chamber, having the shape of a photographic camera. At the larger end is fixed the fluorescent screen; at the smaller end is an opening (fitting the examiner's forehead) through which the shadows on the screen may be observed. With a fluoroscope a darkened room is unnecessary. The majority of fluoroscopes are provided with a handle for holding the apparatus. More recent ones are so constructed as to permit of the easy removal of the screen. (See Fig. 104.)

The fluorescent screen mentioned above consists of a coating of platino-cyanide of barium, spread evenly upon a supporting sheet. A layer of varnish is carefully applied, so as to prevent this fluorescing material from falling off, and likewise to keep it dry. As the fluorescence of the screen is not very brilliant, a dark room must be employed, otherwise rays of ordinary light will interfere. The screen being adjusted in the frame, the chemical surface further protected by isinglass, and the light excluded from the tube by means of black paper, beautiful shadows are portrayed by placing the object between the tube and the screen. When not in use the screen should be kept free from dust and moisture.

There are other chemical agents besides those mentioned which possess fluorescent properties and are adapted for screens. Thus Edison, who examined 1800 chemicals,<sup>2</sup> found that tungstate of calcium fluoresced with six times more intensity than platino-cyanide of barium; next in brilliancy was tungstate of strontium. Salicylate of ammonium (crystals) fluoresces as much as double cyanide of potassium and barium; the former's fluorescence, however, increases with the increase of the thickness of the crystal layer. Other substances that fluoresce under the action of the rays are mercurous chloride, cadmic iodide, calcium sulphide, potassium iodide, potassium bromide, etc.

The only two of the many fluorescent salts employed in the manufacture of screens are platino-cyanide of barium and calcium tungstate. The former affords a brilliant yellowish-green fluorescence, the latter a less intense bluish-white. This bluish white fluorescence offers a greater photo-chemical activity, and is therefore employed as an intensifying screen in radiographic work. Under the name of "the collapsible cryptoscope," H. W. Cox & Co., Ltd., of London, have placed upon the

<sup>1</sup> Proceedings of the Accademia Medico-Chirurgica di Perugia, vol. iii., No. 1-2; also the Scientific American, March 28, 1896.

<sup>2</sup> Elect. Review, New York, April 19, 1896.

market a fluoroscope, which apparatus is fitted with accordion folds, that readily permit of easy adjustment. This cryptoscope has given satisfaction, but its exorbitant price makes its general employment prohibitory.

#### B. SKIAGRAPHIC TABLE.

A skiagraphic table consists of a strong rectangular frame of wood over which is stretched some fabric, or thin leather, which is radio-scopically transparent. The frame, which is supported by four uprights (one at each corner) 18 to 20 inches high, may be covered by a piece of thin, strong board, in order to make it more steady. In making a screen examination, the patient is placed upon the couch with the tube under it, the rays penetrating from below upward. In taking a skiagram, the sensitive plate is placed under the patient and the tube above, the rays passing from above downward. Do not move the screen or the patient if a skiagram is to be taken after making a screen examination; hence an adjustable plate-holder should be fitted to the couch. The tube may be shifted and clamped in any position.

#### C. HOFFMAN'S MEASURING STAND AND EXAMINING FRAME.

This consists of two uprights firmly secured to a platform, and supporting the square or rectangular shaped measuring frame which can be shifted up and down or to the right or left, by turning a few thumb-screws. The adjustable frame is subdivided into smaller squares. The dividing cross-bars are so constructed as to permit of their being shifted into any position and their exact location noted by reading the metric scales at the sides. Accessory frames are placed at the outside of the uprights; one of these acting as a plate-receiver for a skiagram, another supports the fluoroscopic screen for a visual examination.

Lately I devised a table that meets the requirements for skiagraphy, stereo-skiagraphy, and X-ray treatment. (See Figs. 183 and 184.) It is made of wood, and upon the two parallel horizontal metallic tubes, two vertical metallic rods move to and fro, the latter supporting a horizontal sliding bar of wood, from which is suspended the tube-holder. For skiagraphy the tube can be placed under the table, over the table, or in any position in relation to the patient's body. The table is provided with an adjustable plate-holder. The device can be regulated so as to be adapted to any sized plate; it is attached to the vertical rods. This plate-holder with the plate is placed over the part, with the tube beneath the table, or in the sitting posture the plate is placed against the part, and the tube behind the patient. In stereo-skiagraphy the plates can be changed without employing the usual drawer. For treatment, the tube is placed in a leaden lined wooden box, having an adjustable diaphragm





SELF-REGULATING X-RAY TUBE. PUNCTURED OR CRACKED.  
BULB PARTIALLY FILLED WITH AIR.

(Fig. 97.)



with any required sized opening, which is regulated by sliding the movable pieces of wood composing it. The bars and tubings are scaled in inches and centimeters to facilitate the ease of measurements required of the operator.

#### D. TUBE-HOLDERS.

These are of various kinds. For clinical purposes it is essential to have a stand, in order that the tube may be adjusted to any desired height from the floor, at the same time allowing it to project far enough to enable to operator to shift it at ease over the examining table or couch. The base must be heavily weighted, to insure steadiness, and the projecting arm must be firmly clamped. The latter is made of wood or ebonite to prevent any spark from the terminals passing into the metal and thus perforating the tube. Loose clamping must be studiously guarded against; lack of this precaution will produce a blurred photograph, as the swinging tube is made readily tremulous by the amplification of any motion communicated to the stand and arm.

The majority of tube-holders slide on a horizontal bar, the latter being supported by two vertical ones, or it may have independent support from a heavy iron tripod on the floor. The disadvantage of these constructions is that the tube may move or shake if attached to the table, it is clumsy to handle, occupies too much space, and stands in the way of the operator. In offices a couch can be used as a table. It is soft and convenient, and is useful for therapy and examinations. Above the couch, attached to the wall, are two wooden rods grooved on their inner surfaces. A square block of wood slides between the grooves of these two rods, the whole being supported on brackets. Attached to this square of wood, and at right angles to it, is screwed a movable rod, which by tightening or loosening the screw can be adjusted to any angle. This last rod has a small sliding transverse block of wood through which passes the vertical metallie rod, holding the clamp. A similar metallie rod is attached to a sliding rod for supporting a leaden screen, which protects the operator.

Lately I devised a tube-holder in my office made up as follows: A shelf, made of two horizontal bars grooved in their interior, is bracketed upon the wall. Along these grooves slides a block of wood (the carriage). To this carriage is attached a projecting bar of wood, whose angle may be varied at pleasure by adjusting the thumb-screw maintaining its relation with the carriage. By means of an adjustable screw, a second block of wood (transverse to the long axis of the projecting bar) is made to slide to and fro at the will of the operator. Through this latter bar runs the metallie rod, supporting the tube-holder. By means of this holder, freedom of movement is so obtained that the principles of the universal joint



are faithfully portrayed. With this tube-holder the table is dispensed with, and a couch or sofa is substituted upon which a board is placed if necessary, for supporting the sensitive plate. (See Fig. 200.)

#### E. BOX-COVER FOR X-RAY TUBE.

This consists of a wooden box covered on its inner surface by a thick coating of lead oxide. On one side of this box is a hole (4 to 5 cm. in diameter) for the transmission of the rays. This circular aperture is shielded by a wooden diaphragm of heavy sheet lead, having three different sized apertures, and by adjustment the desired opening can be brought in direct line with any part of the body. Luminous effects are excluded, and the dangers of burning by the rays are reduced to a minimum. It must be remembered that the diameter of the rays (cone-shaped) increases as the distance the tube is placed from the patient.

In some tube boxes, instead of the lead foil, several layers of lead paint are used for coating the interior of the box. The size of the box varies in different models. In some instances they are made so large as to be an inconvenience, while in other cases they are too small to secure perfect insulation.

#### F. DIAPHRAGM.

The diaphragm was formerly used for sharpening shadows on sensitive plates. It may be made of metal or glass, with an aperture in the centre for the transmission of the rays. In the glass variety, the excess of lead acts as an obstacle to their passage, the rays being almost wholly transmitted through the aperture. If the diaphragm is metal, it should preferably be grounded, to obviate the danger of puncturing the tube by sparks jumping from it. The object of the diaphragm is to prevent the passage of the rays to other parts than those examined.

*Compression Diaphragm.*—This appliance, devised by Albers-Schönberg, consists of a metallic tube, having one end applied against the part to be skiagraphed, and the other end so adjusted as to receive the rays emanating from the Crookes tube. By its use we secure immobility of the part, mechanically lessen the thickness of the structures under examination, and totally exclude all the secondary rays. (Fig. 99.) In Fig. 98 is illustrated the ordinary diaphragm, wherein is depicted the passage of the indirect rays, *b b*, affecting that portion of the plate indicated by the slanting parallel lines; this is entirely obviated in the compression diaphragm, where *a a* are the direct rays from the anode. (See also Figs. 192 and 193.)

Dr. Henry Hulst<sup>1</sup> states that the use of this diaphragm is most valuable in the skiagraphy of renal, spinal, and pelvic conditions. Thus, in

<sup>1</sup>Transactions of the American Röntgen Ray Society, September, 1905.

cases of suspected renal calculi, the employment of the compression diaphragm materially lessens the number of diaphragmatic movements of the patient, and as the kidney moves with each movement of the patient's diaphragm, the steadiness of the kidney is markedly increased, in consequence of which, a skiagram of a renal calculus will not be blurred.

The serious disadvantage of the compression diaphragm is the fact that only a very small area can be skiagraphed at one time, while the

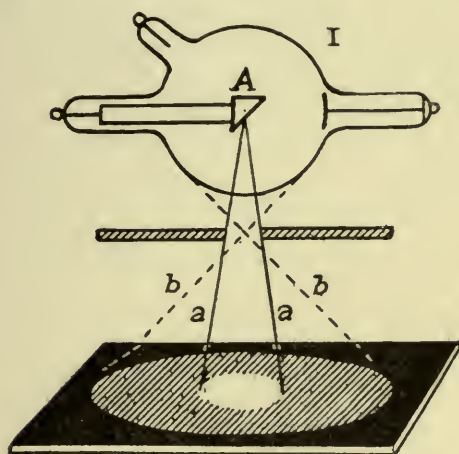

FIG. 98.—Ordinary diaphragm.

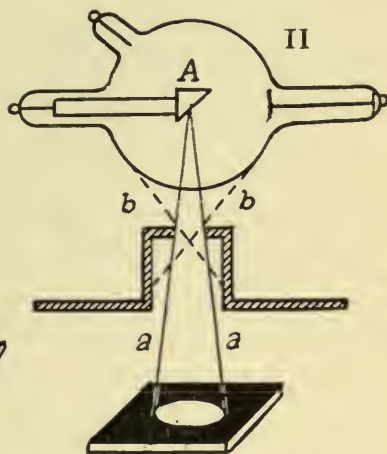

FIG. 99.—Tubular or compression diaphragm. (Donath.)

stone searched for may be located outside the part covered by the cylinder. This method prevents a negative being taken of both sides for the sake of comparison; a most necessary and invaluable guide.

Although largely used in Europe and America, I do not advocate the employment of a compression diaphragm, as, with greater refinements in the technic, the time of exposure has been so materially lessened that there is a marked decrease of the secondary rays, and without the diaphragm a large area is exposed for examination on the plate.

#### IV. The Selection and Installation of X-ray Apparatus.

##### A. SELECTION OR CHOICE.

In equipping an X-ray laboratory several factors must be considered. The scope of the work, the portability of the instrument, the necessary expenditure that will be incurred, the requirements of the apparatus for the office, the city or country hospital, and the fact whether the purchaser is an X-ray specialist or a general practitioner.

By the scope of work to be accomplished we mean the extent of usefulness of an X-ray outfit. A small coil will suffice for the work that a

beginner may be required to do, but the purchase in the beginning of a large coil, which will prove more lasting, is wisest because increase of work will early demand this improvement in the apparatus.

*Hospital (City or Country).*—In the majority of city hospitals a 110-volt current is supplied for working a coil. The coil that is installed in the laboratory of a large city hospital should have a spark length of from 12 to 20 inches (30 to 50 cm.). It should be so constructed as to be capable of conveyance to the various parts of the hospital. The coil can be worked by attaching a connecting head to one of the electric light sockets from which leads extend to the coil. If the hospital is not lighted by electricity (110-volt current), it becomes necessary to prepare a place on the main shelf of the carriage, or on the second shelf, for placing a storage battery, by which means the coil then must be worked. When patients can be conveyed from the bed to the laboratory, much labor is saved.

In country hospitals and sanitarium, where there is difficulty in obtaining either continuous or alternating current, static machines are recommended for exciting the Crookes tube, and also for therapeutic purposes. For exciting a tube the use of a water motor or a small gasoline or gas engine must be resorted to. If expense be a matter of moment, I then recommend a coil worked by a secondary battery. The physician's or surgeon's outfit should be portable. He should employ an 8- to 10-inch (20–25 cm.) spark, worked by a storage battery. For examinations in a private office the use of a static machine (run by an electric motor), instead of a coil, is recommended. The expert should have in his possession an outfit capable of meeting all emergencies. It should consist of two coils and a static machine. In his private office he should have a stationary coil with a spark-producing power of from 18 to 22 inches (45 to 55 cm.), and a second coil so constructed and arranged as to allow of its ready transportation, the latter to be capable of giving a spark from 8 to 10 inches (20–25 cm.) long. This portable coil should be worked with a storage battery.

*Portable Outfits.*—The necessity of moving an X-ray apparatus requires the outfit to be as compact and light as possible. In the latest forms of apparatus the coil and accessories are carefully fitted into a case which makes it readily transportable. The cumbersome storage battery must be conveyed separately with the coil, etc. The latter should be 8 to 10 inches (20 to 25 cm.). The more recent accumulators are very light and compact.

## B. INSTALLATION.

It remains to give a brief résumé of the arrangement and management of the different parts concerned in the production of a skiagraph. The first essential is to determine the nature of the current available.



The coil can be energized by an accumulator or by the continuous or alternating current from the street supply. In the latter instance the transformer is necessary to reduce the enormous voltage. Some place the coil upon the table; my own preference is to rest it upon a shelf attached to the wall, thus space is saved and the operator is kept away from the

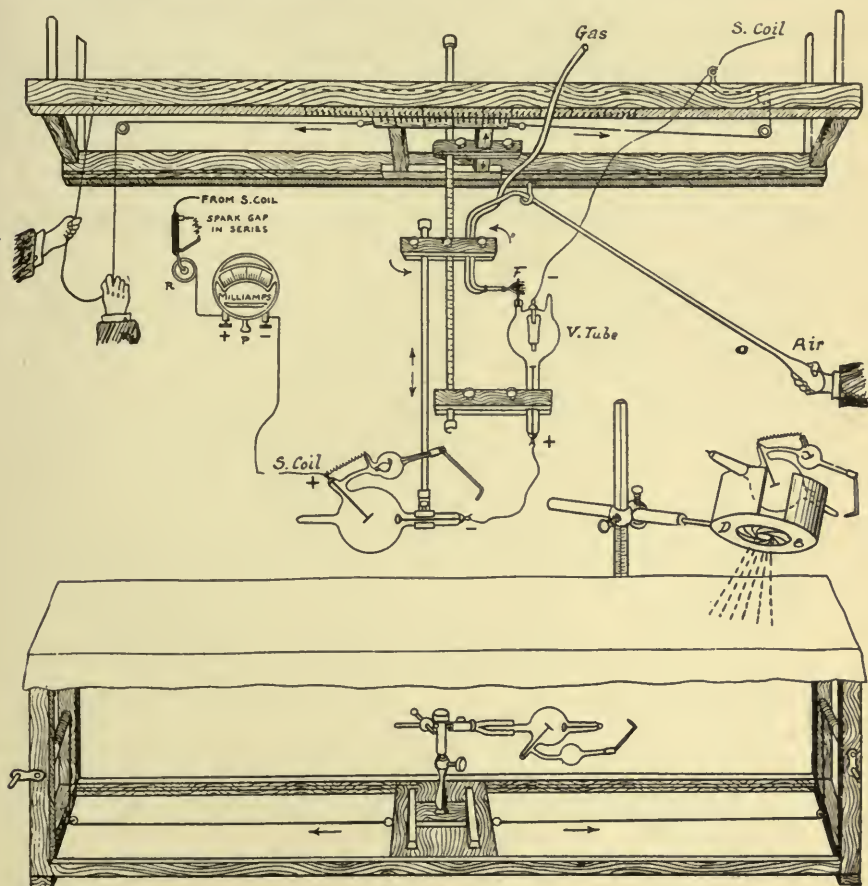

FIG. 100.—AUTHOR'S TABLE AND TUBE-HOLDER.—The pulley moves the tube-holder to and fro. The ventrill tube is connected in series with the Crookes tube and lessens the "reverse current," whose vacuum can be lowered, at pleasure, by the operator compressing, at a distance from the tube, a bulb, which drives a blast of air into a gas flame, thus allowing the heating of the platinum in the ventrill tube.

magnetic field. The latter method is prevalent in Germany. The controlling apparatus (the interrupter, rheostat, switch-board, etc.) should be within easy reach. After installing the coil, the source of current can be connected with it by the use of the switch-board. The switch-board is provided with several binding posts, the latter being connected with

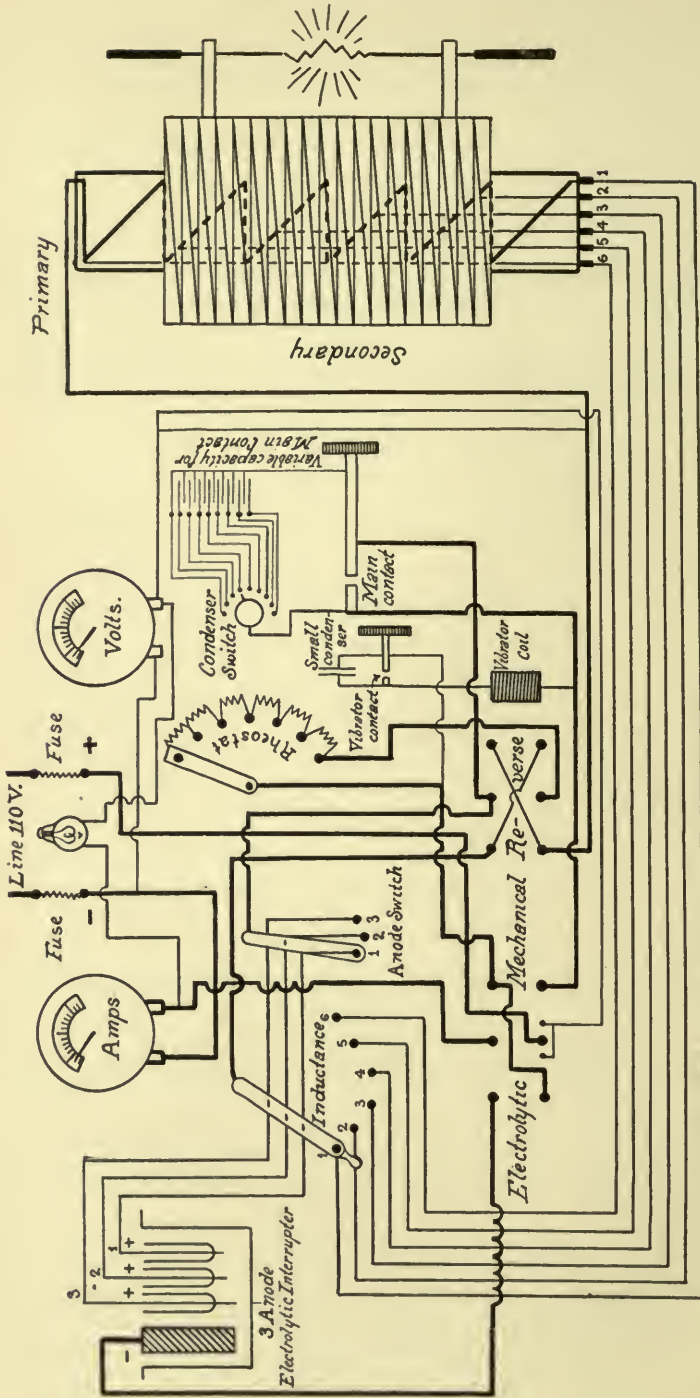

Fig. 101. — Diagrammatic view of the installation of the "jumbo" coil and its connections with the variable primary coils, as used by me in the Philadelphia Hospital.

the accumulator and likewise with the direct current. A double switch-thrower connects the current with either the accumulator or the direct current. Another switch can be made to connect the current with either the mechanical interrupter or the Wehnelt break. For charging the

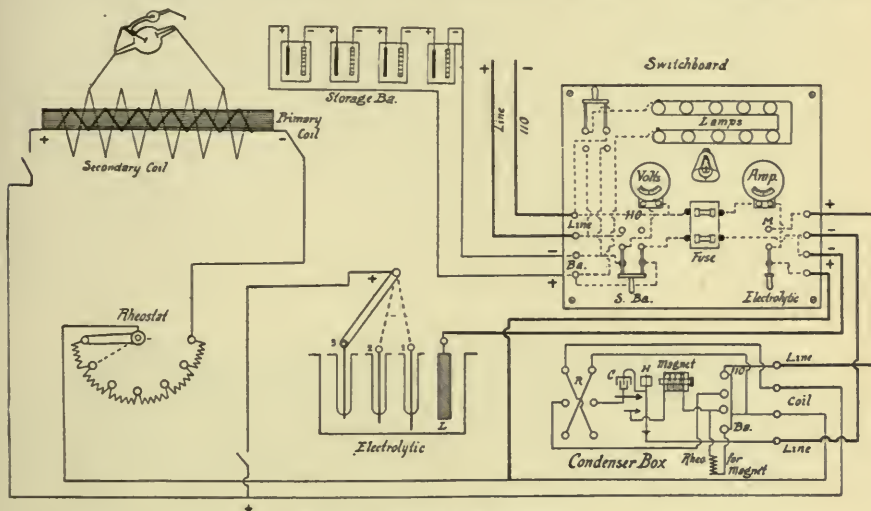

FIG. 102.—Author's office outfit.

accumulator a bank of lamps is provided; the remainder of the switch-board is made up of the fuses, the ammeter and the voltmeter. The author's table and tube-holder and method of installation are illustrated in Figs. 100, 101, and 102.

### C. POLARITY AND CONNECTION OF TUBE.

Next to be considered is the connection of the terminals of the secondary coil to the tube. To do this properly it is necessary to ascertain the polarity. The following methods may be applied:

(1) Dip the ends of the two wires into dilute sulphuric acid or water. The negative wire shows a free development of gas; this does not occur with the anode, which is colored black from the deposition of copper oxide.

(2) Moisten the paper with potassium iodide, bring the poles in contact with it; the presence of a black stain indicates the anode.

(3) By means of a small tube filled with a liquid into which platinum wires project; the application of a negative pole is followed by the liquid being dyed a red color.

(4) The polarity can also be determined by the peculiar color of the spark on the terminal electrodes of the secondary coil; the cathode shows the presence of a thick, whitish spark, while the anode shows several wiry lines of spark of a pink color. (Fig. 103.)



The leading wires should be connected with the proper terminals of the tube by thin, well-insulated copper wire. This connection to the terminals should be provided, on each side, with at least one inch of spark-gap. The wires should be separated at a distance from each other, from the tube, and also the patient, greater than the length of the parallel spark-gap (where the wires are attached to the tube they are supported by a non-conductor). The current must not be turned on before all connections are completed, else there is danger of severe shock both to the operator and the patient. Wrong polarity can be easily determined by the appearance of the tube, and corrected by the commutator.

After the polarity has been ascertained the ends of the tube may be connected to the respective terminals. The connecting wires should be thickly coated with gutta-percha to prevent leakage and also possible puncture of tube. There should exist multiple spark-gaps in series, as



FIG. 103.—The polarity as determined by the appearance of the spark.

this device improves the quality of the rays and prevents or lessens the "inverse" current within the tube. After the tube has been lit up, the spark-gap between the ends of the tube and the brass balls should be adjusted until the best results are obtained.

*Advantages of the Static Machine.*—The static machine requires little attention and is nearly always ready to generate electrical energy, of a high potential. The current is almost perfectly continuous through the tube, and hence the illumination of the fluoroscope is steady. The radiation and the penetration of the rays of the tube may be modified by varying the interval of the spark-gap (in series). The static current may also be used as a therapeutic agent.

*Disadvantages of the Static Machine.*—Should the beginner purchase a coil or a static machine for X-ray work? A definite answer cannot be given unless the scope, kind, and the place of work be considered. I employ both the static machine and the coil, the static for electro-therapeutic purposes, and the coil for X-ray work. I have stated the merits and demerits of the static machine; the converse of these assertions holds



good for the coil. If the leads are freely "brushing" the tube may be seriously interfered with. These brush effects fill nervous patients with fear; hence it is difficult to keep them steady for a sufficient length of time required for the exposure. It must be remembered that a small amperage of static current does not produce the necessary penetration for good skiagraphic or fluoroscopic effects of the deeper structures of the body, nor is it adapted for short exposures; this can be partially remedied by augmenting the number of plates or by increasing the speed. If non-breakable plates are employed, the speed of revolution may be increased manifold, without increasing the number of the plates, and the deficiency is thus overcome in X-ray work. Other objections that may be urged against these machines are their bulkiness and the sudden and frequent changes in their polarity and failure to work in damp weather.

## CHAPTER II

### THE PRINCIPLES OF TECHNIC.

#### I. Fluoroscopy.

HAVING briefly described the X-ray apparatus and the modes of its manipulation, we shall now dwell upon the methods of its practical application.

When conducting such examinations, it is essential, though not absolutely necessary, to have the room darkened so as to exclude ordinary light. Of course the rays are invisible. The means employed for detecting the presence of the invisible Röntgen rays are (1) by its physical effects,—*i. e.*, the ability of these rays to produce a fluorescence from certain substances; (2) by the chemical effects taking place on the sensitive plate.

For making fluoroscopic examinations we may employ either the fluorescent screen or the closed fluoroscope. A cryptoscope has been brought into the market which allows of the detachment of the screen from the hood, Fig. 104, thus permitting of the use of the former without the cumbersome attachment.

#### A. METHODS OF EXAMINATION.

(a) *Screen Examinations.*—By daylight the fluorescence of the screen is wholly imperceptible. Hence the necessity of excluding any light that might fall upon the screen and the eyes of the examiner.

The brilliant fluorescence becomes manifest only in a darkened room, and, therefore, as in Röntgen's original experiment, in order to exclude this extra light the tube should be covered with some dark material.

The examiner holds the open screen in his hands, shifting it to the part desired, or it may be clasped to an adjustable rod attached to a frame which rests upon the floor. When the open screen is used, it should be brought as close as possible against the part under examination, so as to bring out the shadows more distinctly.

Prior to covering the tube, it must be placed in its proper position, preferably with the platinum anode pointing toward the operator; the patient is then placed in front of the excited tube. (The cryptoscope is used in a lighted room.) In order to make a thorough examination the examiner's eyes must get accustomed to the darkened condition of the interior of this apparatus. When used on a sunny day, only the dark contour of the part under examination is first seen, gradually giving way to the more distinct details. Long and frequent examinations by this

means tire the eyes, often producing conjunctivitis among operators. For superficial and preliminary examinations this appliance is indispensable, but for deep examinations the open screen and dark room, with the tube's phosphorescence shielded, are to be recommended.

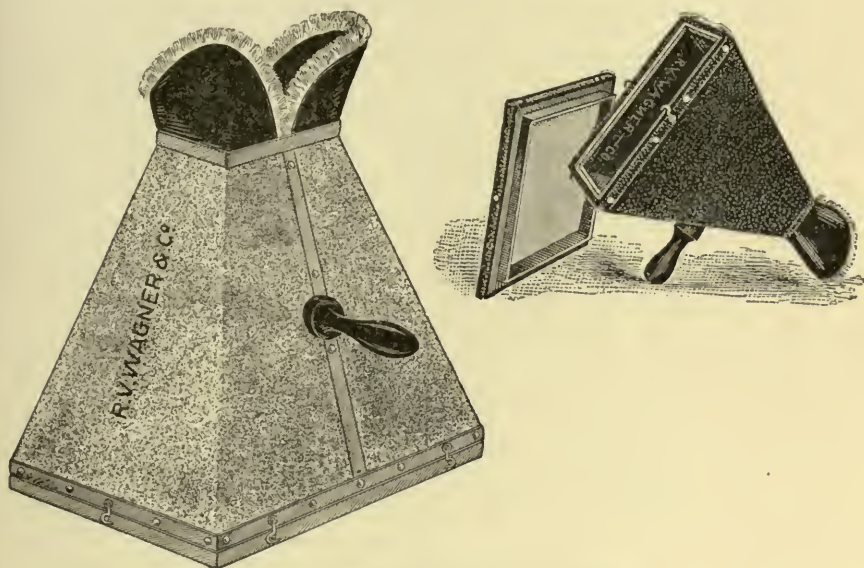

FIG. 104.—Detachable fluoroscope and screen.

With a cryptoscope only one person is enabled to view the images cast upon the screen. When the screen alone is employed a group of persons can see the existing conditions, hence, the latter's value for demonstrative purposes.

(b) *Preparation of the Patient.*—Always remove the clothing of the patient from the part which is to be examined, permitting in some instances the retention of the under garment, which should, however, always be free from wrinkles. Pins, buttons, and any other metallic structures which would cast shadows upon the screen must be removed, to prevent an incorrect diagnosis.

In surgical cases where fine detail work is demanded, it is necessary to remove all the garments from the part to be examined, also splints, bandages, and powder dressings, as acetanilid, iodoform, boric acid, and plaster of Paris, all of which produce shadows upon the screen. The retention of wooden splints, though offering little or no obstruction to the rays, interferes with a thorough examination of a part on account of the immobilization of the joints, the ends of fractured bones, etc. These splints act as stays and do not permit of any movement of the part or of the close approximation of the screen.

(c) *Position of the Tube.*—The tube should be carefully clamped into the notch of the holder so that the platinum anode points to the screen's centre, causing it to fluoresce equally. The rays should pass in a straight line and not obliquely from the tube to the object. When examining the

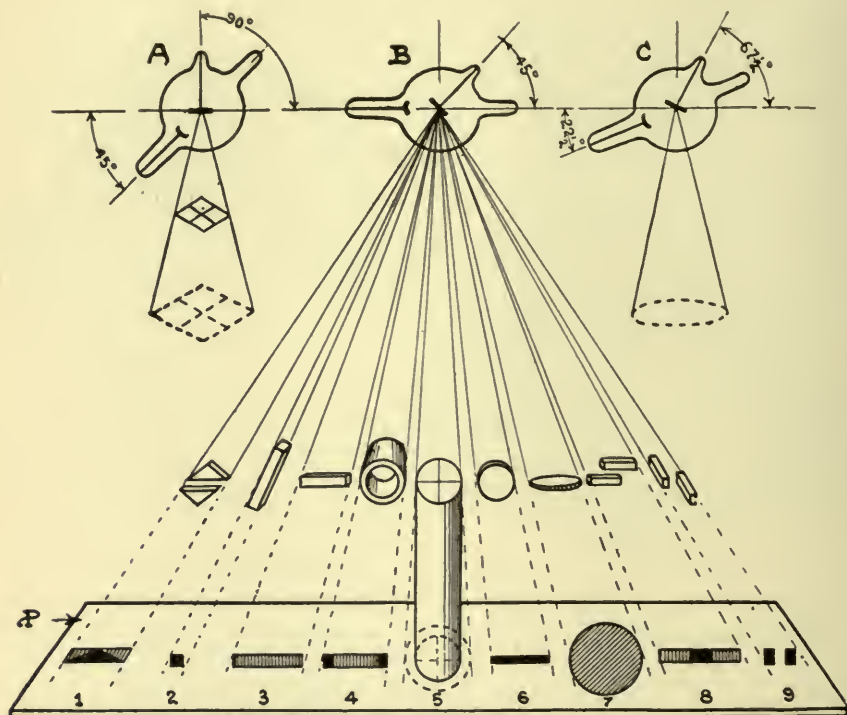

FIG. 105.—A STUDY IN SHADOW DISTORTIONS (FLUOROSCOPIC OR SKIAGRAPHIC) WITH CORRESPONDING DENSITY DIFFERENCE.—A, Anode parallel with the photographic plate. B, Axis of the tube parallel with the plate. C, Tube midway between the above positions.

1, Either position of the object will throw the same shadow; the darker portion indicates the denser portion, whether the vertex is up or down. 2, Shadow smaller and denser. 3, Same object slightly enlarged. 4, Cylinder or bone. Shadow denser at the extremities, because the rays must traverse more substance at those positions. 5, Metallic cylinder. To ascertain the perpendicularity of the rays, cross wires are placed upon both ends, when the shadows of the latter will superimpose on the plate or fluoroscope. If these shadows do not superimpose, the rays are taking an oblique course. 6, Penny on its edge. The shadow line is dense, as the rays traverse much substance. 7, Surface view of the same. 8, Fracture of two bones. The shadows, being superimposed, cast a very dense shadow. 9, Rays traverse through less substance when the bones are longitudinally arranged, and cast less dense and separate shadows.

thorax, for example, the tube should be so positioned as to cause the rays to fall perpendicularly upon the screen. When examining a field near the first, it is advisable to have the tube remain stationary, and to move the patient as necessary.

Experience alone will guide the beginner as to the distance most suitable for producing the best images upon the screen. For fluoroscopic



work the patient is usually brought closer to the tube than when a skiagraph is taken. The shadows on the screen may often be sharply brought out by a careful and systematic adjustment of the distance between the patient and the tube.

(d) *Position of Patient.*—The patient may be examined by means of the fluoroscope in the lying, sitting, or standing positions.

(e) *Size, Shape, and Intensity of Image on the Screen.*—The X-rays diverge as they are projected from the anode. The shadow thrown on the screen, therefore, will be larger than the object itself. If the object is brought closer to the tube the distortion in size will be increased. The further the fluoroscope is separated from the object, the larger but less definite will be the shadow cast. If the rays do not fall perpendicularly, the shadow on the screen will be distorted. This can be well illustrated by the following experiment. (Fig. 105.)

Take a lighted candle and hold it fifteen or twenty inches (38 or 51 cm.) from a white surface; between it and the candle place a coin. Upon moving the coin toward the white surface, its shadow becomes smaller and smaller as it is gradually made to approach that surface. The reverse occurs when the coin is moved from the white surface toward the candle. Upon altering the plane of the coin a shadow of different shape is produced. When the rays fall perpendicularly on the surface of the coin, the shadow produced will be circular, but when tilted so that the rays strike in an oblique direction, the shadow cast will be elliptical. The change in size and shape of the shadow can be accomplished by altering the position either of the source of light or of the object. These principles are equally true in fluoroscopy and skiagraphy.

The intensity of the shadow on the screen, even of the same kind of structure, will vary in different individuals. Thus the shadow of the adult male thorax will be darker than that given by a child's thorax. This difference in intensity depends upon the degree of penetrability of the rays, the distance of the tube from the fluoroscope, and the relative thickness of the part.

The operator should be thoroughly conversant with the normal appearance of the parts, so that he can use this knowledge as a standard of comparison for the corresponding affected part in the same individual.

## B. ADVANTAGES OF FLUOROSCOPY.

The method of using the fluoroscope is simple, inexpensive, and rapid, and allows of immediate comparison with the corresponding normal part. The mobility brought about in the structure under examination permits of its study in different positions. In examining certain parts that are in constant motion, as the heart, diaphragm, and thorax, a study can be made of any abnormality in their movements.

### C. DISADVANTAGES OF FLUOROSCOPY.

One of the limitations of this method is that the record is not permanent, although "tracings" can be made. In prolonged exposures for examinations the patient is liable to be "burnt," and the same injury may befall the operator's hands and eyes; for this reason, I at present never employ the fluoroscope, having discarded its use five years ago. Thicker parts, as the adult abdomen, the hip, and the skull, do not permit of satisfactory examination by this method. The same is true of certain fractures which present no displacement of the fragments (fissured fractures), also in detecting and locating small foreign bodies. As the soft structures present varying degrees of density, the presence of diseased bone, tumors of muscles or of the brain, etc., cannot be differentiated, owing to the affected tissue having only a slightly different density from that of the surrounding normal parts. As the penetrability of the rays cannot be controlled, and the varying degrees of density confuse the eye, the differentiation by means of the fluoroscope becomes at once most difficult and unsatisfactory.

## II. Skiagraphy.

### A. SYNONYMS, DEFINITION, AND NOMENCLATURE.

Skiagraphy (Röntography, Shadowgraphy, Ixography, Electrography, Skotography, Kathography, Fluorography, Actinography, Radiography, Diagraphy, Skiography, Pyknoscopy, New Photography, and Electro-Skiagraphy) is the art of photographing shadows on sensitive plates by means of transmitted light. The Röntgen Congress in Berlin on May 2, 1905, adopted a uniform nomenclature for the use of the Congress and for expression in writing. The following terms will be used in the future: Röntgenology, Röntgenoscopy, Röntgenography, Röntgenogram (Röntgen negative, Röntgen positive, Röntgen diapositive), Ortho-Röntgenography, Röntgentherapy, Röntgenizing. I present this new nomenclature, but I can hardly endorse it. I believe that the word "skiagraph" and its modifications are more easily pronounced, more general, and more euphonious.

The differentiation between an ordinary photograph and a skiagraph is as follows: A photograph is an image produced on a sensitive plate in a camera by ordinary light, reflected from the surface of the object, converging and passing through a lens or pin-hole and then diverging and falling, thus producing a reduced size of the image on the plate. Therefore, a photograph is a "reflected" picture, and we see only that part of the object that is near or toward the optical perimeter when the object is opaque; if transparent, the refraction obscures the clearness of the farther side.

**PHILADELPHIA HOSPITAL**  
**RÖNTGEN RAY LABORATORY, RECORD OF DIAGNOSIS.**

No.

1	NAME	ADDRESS	Nativity	Month	Day	190
			Occupation			
2	SEX <span style="font-size: small;">Male Female</span> Age <span style="font-size: small;">Single Married</span>	Color	Weight lbs.	Department	Referred by	M.D.
		Height		Ward	Address	
3	Previous History					
4	Date, Place, Duration, Character, etc., of Injury or Disease.					
5	Part or Organ Involved					
6	SYMPTOMS {	Physical and Clinical				
7						
8	Chemical and Microscopical Examinations					
9	REMARKS					

Technic Employed in Diagnosis.				Diagnosis made from Skiagram or Fluoroscope or Stereo-Skiagraph			
<b>I</b> APPARATUS		<b>II</b> POSITIONS OF THE TUBE AND PATIENT		<b>III</b> QUALITIES OF THE RAYS, TIME OF EXPOSURE			
STATIC MACHINES	A Varieties and Make	Distance of Anode from Plate		Current going to the Primary Coil			
	Revolving Plates	inch	cm.	Volts		Amp.	
	Number	Thickness of the Part		Secondary or Induced Current			
	Diameter	inch	cm.	Milliamperes			
	Rev. per Minute	<b>POSITIONS OF PART</b>		Parallel Spark-gap			
	Length of Spark-gap	Antero-posterior		inch			
	inch	cm.	Lateral		No. of Benoist's Scale		
SOURCE OF CURRENTS	B Accumulator	Volts	Flexion		Degree of Vacuum of Tube: Low (soft), Medium, High (hard)		
	Ampere-hour		Extension		Time of Exposure		
	Direct Current		Dorsal Decubitus		sec.	min.	
	Altern. Current		Ventral Decubitus		Intensifying Screen		
	Transformer		Recumbent		Variety of the Plate		
			Semi-recumbent		Sizes	Nos.	Parts
KIND OF COILS	C Varieties	Sitting		X	A		
	Length of Spark-gap	Standing		X	B		
	inch	With or without Bandage, Splint, Cast		X	C		
	cm.			Negatives *			
INTERRUPTERS	D Varieties	E	Varieties	Over or under-exposed or developed, Patient moved			
	No. of Interruptions	CROOKES TUBE	Non-Regulating	No. of Prints			
	Per Minute		Self-Regulating	Duplicate			
	Mechanical		Osmo-Regulat.				
	Mercury						
Wehnelt							
Caldwell							
Simon							
				OPERATOR			
				AUTOPSY			

Diagnosis made by Director..... M.D.  
or Assistant..... M.D.



In skiagraphy the X-rays emanate from a small point (1 mm. anode), diverge and pass through bodies opaque to ordinary light, throwing a relative shadow of the object on a sensitive photographic plate, producing merely an actual silhouette. The skiagraph, therefore, is produced by transmitted light.

Before taking a skiagram, determine the best possible position that can be secured, by first employing the fluoroscope, and then substituting for it the sensitive photographic plate. On the latter the image cast will appear reversed,—*i.e.*, the bones will appear white and the surrounding soft structures darker, due to the fact that in the bones more rays will be absorbed, fewer penetrate, and hence there will be decreased oxidation on the photographic plate. When a photographic print is made from this negative, the appearance will be identical with the fluoroscopic image. (Hereafter the term *skiagraph* or *skiagram* will be used for the printed positive, and the developed sensitive (photographic) plate will be termed the *negative*.)

## B. THE PATIENT.

*History Taking.*—It is advisable to take complete histories of all cases. I employ the accompanying blank in book-form in the Philadelphia Hospital and in private work. Its main features are, the history of the case and the technic employed in each instance.

*Preparation of the Patient.*—Expose the part to be skiagraphed by removing the clothing. If the part is an extremity, have it totally bared. When examining the chest or abdomen, should the patient be chilly or complain of the unpleasant sensation caused by the plate, or be abashed at the thought of completely disrobing, the wearing of an undergarment may be permitted, or the part may be covered by a sheet of white linen, care being taken to remove buttons and pins, and not permitting any wrinkles or creases to exist in the field to be examined. If a part of the forearm or leg is to be examined for fracture, dislocation, etc., splints and dressings of iodoform, borie acid, bismuth subnitrate, lead water and landanum, etc., must all be removed and the part skiagraphed in a bared condition. If a compound fracture is examined, avoid infection by covering with a thin sterilized gauze. In examining the abdomen, a purgative should be administered ten or twelve hours prior to the examination. The patient must not be permitted to indulge in eating solid food previous to the examination. The urinary bladder should be emptied before being skiagraphed, for calculi, and a rectal enema given. The walls of the stomach may be readily outlined by having the patient ingest large doses of bismuth subnitrate for two weeks prior to the examination.

*Position of Patient.*—The patient should be placed in a comfortable position. It is sometimes not possible to do this, hence the necessity of



conducting the examination rapidly, but without sacrificing the results desired. In order to ascertain the necessary position for the patient to occupy first examine with the fluoroscope.

The patient may assume various positions in skiagraphic work, which will be dealt with under the various clinical conditions. They are: the erect or sitting, anterior, posterior, or lateral, recumbent, dorsal decubitus and ventral, named after the position or view of the part that is in contact with the sensitive plate or fluoroscope.

*Immobilization of the Part.*—To obtain the sharpest outlines on the plate, the patient must not be permitted to move while under examination, or failure will be the inevitable result. Those that are timid should be previously instructed to ignore noises, flashes, etc., necessarily occurring during the examination. It is better for the skiagrapher to have an under-exposed plate rather than one that is blurred. This blurring may be independent of the patient, and be caused by the shaking of the tube or the table, or of both.

The part to be examined may be held in one position by firmly strapping it to the table, although I seldom find this necessary. In certain cases, as in fractures, where there is movement of the part (the result of muscular spasm), the annoying symptom may be met by steadying the limb with sand-bags, etc. When it is found impossible to keep children and the insane under control, resort must be had to hypodermic injections, or to the administration of an anæsthetic.

### C. PLATES, THEIR PREPARATION, SIZE, AND PROTECTION.

The plates as sent by the maker are not ready for use; hence it becomes necessary to assort and arrange them in a dark room, so that they may be conveniently handled by the examiner. Place the plate in a black paper envelope, which in turn is covered by a heavy yellow one; this prevents injury by light, though it will be affected by the X-rays with as great ease as desired. The size of the plate depends upon the dimensions of the part to be skiagraphed; those that I usually employ are one size larger than is absolutely necessary. The plate should be protected against breakage, damage from perspiration or other excretions of the body, and from heat. To insure against breakage, it should be placed over a smooth board, as I find that a plate-holder is objectionable in preventing the approximation of the plate close enough to the part to be examined, thus preventing sharp definition of shadows. Between the patient and the plate I introduce a blotter or a sheet of aluminium, oiled silk, or celluloid, which prevents injury from sweat, urine, etc. For the sake of comparison, it is a wise provision to have the plate large enough to take both sides of the body (hips, shoulders, etc.). For this purpose, place the tube in the median line of the body and take

both sides with one exposure. This obviates the error that would result if the two sides were taken separately, when in all probability the positions would be different. Where the plate cannot be brought in contact with the part, owing to a curvature of the latter, as on the flexor or extensor surfaces of the elbow, or on the spine, in common with others, I at times resort to the use of a film. The plate should be placed against or under the part examined, with the gelatine side up. The part should be as nearly centralized on the plate as possible, so as to get the important outlining shadows directly in the centre of the plate. Rays should fall as nearly perpendicular as possible.

*Data on the Negative.*—It is always advisable that the plate should be marked so as to guard against errors. The method of plate-marking that I employ consists in placing lead letters and numbers in reverse type in the corner of the plate, designating the part examined, the date, the name of the operator, and also the name of the institution. The letters and numbers employed for this purpose should be small, so as to not occupy too much space on the plate. When exposing a part I usually indicate on the plate whether "right" (R) or "left" (L). When making more than one exposure of the same part, I usually indicate the number of separate exposures consecutively by placing on the plate the lead letters, A, B, and C. In medico-legal cases an identifying mark is most important.

#### D. SELECTION AND USE OF THE CROOKES TUBE.

The Crookes tube must be selected according to the requirements of the case. Thus, the "hard" tube, which produces a greater degree of penetrability of the rays, is adapted for the thicker parts, in detecting the larger foreign bodies, and in taking a negative of a fracture through a plaster cast. In making skiagraphs of children, where their movements would ordinarily blur the negative, the short exposure required by this variety of tube is a marked advantage.

When soft tissue differentiation is to be brought out, as in skiagraphing a muscle tumor, a cyst, a small foreign body, or a tuberculous focus in bone, resort must be made to "medium" or even "hard" tubes.

The consensus of opinion among the profession is that a soft tube is desirable for skiagraphing soft tissues in order to obtain a clear tissue differentiation. But I have abundantly proved that with a hard tube, a short exposure, and proper development, the same end may be attained. The advantages of the latter method are: The time of exposure being brief, the liability of movement of the patient is minimized and there is less liability of penetration than with a soft tube of a longer exposure.

*Position of the Tube.*—Some investigators claim that no X-rays are produced back of the anode, others assert that they do exist in this

position but possess very little penetrating power. As to whether the rays are uniform in penetration in the active hemisphere, or if they possess a point of maximum intensity, is another disputed question. Buguet and Londe assert that the intensity of the rays varies at the active hemisphere in different tubes, and in different kinds of the same tube. In some tubes the most effective X-rays are evolved at right angles to the axis of the tube; in which case the latter must be placed parallel to the object to be skiagraphed. In other tubes the zone of greatest intensity is at a right angle to the plane of the anode, when the anodal surface should be in the centre and parallel to the object under examination. I prefer a position intermediate between these two. (See Fig. 105, C.)

M. Bordier<sup>1</sup> says: "The direction of this principal axis, along which the Röntgen effects are at a maximum, must be determined separately for each focus-tube, and it evidently lies in the median plane,—*i. e.* in the plane passing through the centre of the cathode and perpendicular to the anti-cathode."

He placed a series of pastilles in an arc, having for a centre the focus of the anti-cathode; the direction of the principal axis was given by the pastille which was most discolored.

In experiments on three Müller tubes tested in this way it was found that the principal axis made an angle of  $70^\circ$  with the line passing through the centres of the cathode and the anti-cathode.

*Form of the Ray-emitting Area of the Anti-cathode.*—Gocht,<sup>2</sup> in experimenting with a pin-hole camera, succeeded in photographing a luminous area on the surface of the anti-cathode, the ray-emitting area having a pyriform-ovoid shape. He asserts that the angle between the plate and the anti-cathode at which the spot of light is most circular and there is least penumbra is not  $45^\circ$ , but nearly  $65^\circ$ .

*Direction of the Rays.*—Rays emanating from Crookes tube should fall perpendicularly. To prove this, place a metallic cylinder, 3 or 4 inches long, over the plate or on the screen. If the rays are perpendicular the shadow cast will be circular; if the rays are proceeding in an oblique direction, the shadow will be elliptical or the shadows of two cross wires on both the ends will not be superimposed. (See Fig. 105, 5.)

*Distance of the Tube from the Plate.*—The thicker the part and the greater the extent in area to be skiagraphed, the greater should be the distance between the tube and the object. This distance must be measured from the anode to the plate, and is usually about 20–24 inches (50 or 60 centimetres). Where any movement of the part is likely, it is preferable to place the tube closer, in order to reduce the time of exposure.

<sup>1</sup> Archives of the Röntgen Ray, June, 1906, p. 7.

<sup>2</sup> Ibid., April, 1906, p. 312.



## E. FACTORS VARYING THE TIME OF EXPOSURE.

This is most important ; no definite rule can be formulated relative to the standardization of any unit of time. The time of exposure varies under the following conditions :

1. The capacity of the apparatus and the penetrability of the rays.
2. The peculiarity of the part to be examined.

Under the first heading we must consider the size and make of the apparatus. If the static machine is used, we must take into account the number and size of the plates and the rapidity of the revolutions per minute. In the use of the coil account must be taken of its size, and the variety of the interrupter, with its frequency of interruptions, etc.

Under the secondary heading we consider the thickness of the part and its texture. The thicker the part, the more prolonged must be the exposure ; nevertheless, while the chest is as thick as the abdomen, the latter requires a longer exposure, because the former is more easily penetrated by the rays, due to the contained air.

*Quality of the Rays.*—Rays of high degree of penetrability will require a shorter time of exposure, and conversely with rays of medium and low degrees of penetration. The sensitiveness and variety of the plate play a minor part in the time of exposure. No plate has thus far been found that is specially sensitive to the X-rays only.

*Intensifying Screens.*—Intensifying screens are intended to shorten the time of exposure by placing in contact with the photographic plate a screen of fluorescent substance, the latter acting like ordinary light on the sensitive plate. It must be borne in mind, that the granularity of the fluorescing surface reduces the definition of the skiagram, at the same time omitting details of the smaller bony structures, and the necessity of either using color-sensitive (ortho-chromatic) plates, or first color-sensitizing ordinary plates, since the best screen (platino-cyanide of barium) fluoresces with a yellowish-green light which does not greatly affect ordinary dry plates.

I have conducted experiments that lead me to the belief that the ratio of exposure necessary with an intensifying screen to the time required without the screen is as 1 to 5 or 6. This screen will markedly assist in the reduction of the time of exposure in fractures and the presence of foreign bodies about the thicker structures, such as the hip, the pelvis, and the abdomen. Of course by this procedure we sacrifice the fine details of the softer structures, and for this reason I have abandoned its use.

## F. PREVENTION OF SECONDARY OR SAGNAC RAYS.

When the Röntgen rays penetrate bodies, the so-called secondary rays of Sagnac are produced in the tissues. The rays being primary, the secondary rays will in turn produce rays called the tertiary.



This diffusion or production of secondary and tertiary rays will be increased when the time of exposure is increased and when the part examined is of considerable thickness. In order to prevent these useless rays, which so often cause a foggy appearance on the negative, many devices have been suggested, principal among which are the following :

*The Lead Iris Diaphragm.*—By the method of Albers-Schönberg, —i. e., by means of the compression diaphragm (Fig. 99),—the primary rays are largely cut off, with a consequent lessening of the secondary rays. The irradiated area is diminished in size, and the depth of the parts is likewise decreased, through the pressure exerted by the compressing action of the diaphragm.

Robinson, in Holz knecht's laboratory, modifies the above by pressing upon certain parts of the diaphragm with specially devised metallic rods, in order to make the diaphragm conform to uneven surfaces, such as the ankle, foot, knee, etc.

I have seen Contremoulin, of Paris, applying lead plates against the flanks and chests of patients, to prevent the disappearance of the shadows of soft tissues. He demonstrated the value of this method by employing these plates on one side only. The development of the negative showed in detail the shadows of the soft parts, while on that side where no lead plate was applied the shadows of the soft parts were invisible.

### III. Photography.

The photographic processes involved in the production of a negative from a plate that has been exposed to the X-rays do not differ from those involved in making ordinary photographic negatives. Experience in this branch of X-ray diagnosis is absolutely necessary, hence steady and continuous work is essential, in order to become familiar with the many intricate points which so frequently arise.

*Dark Room.*—The dark room must be absolutely free from ordinary light and so constructed as to allow of ready ventilation. Both of these requirements may be met by utilizing a zig-zag entrance. The room should contain trays, graduates, faucets (for hot and cold water), and a suitable box or tank, encasing vertical grooves, for the purpose of "fixing." As the process of developing, which we shall presently describe, produces a staining of the hands, and sometimes a dermatitis from the action of metal, the use of rubber gloves is desirable. After employing them for a short while, the operator becomes accustomed to them. When the developing is completed, they should be thoroughly rinsed in water and hung up to dry.

*Light.*—When developing, advantage may be taken of the ruby lantern or incandescent lamp, properly shielded. Daylight, on account of

its variability, is unsuited for the purpose. In brief, the room should be glazed with a sash composed of ground glass, a yellow and a ruby glass, and a shade or curtain of a dark color.

*Sensitive Plates and Films.*—Skiagraphs are easily projected on photographic glass plates, papers, or films. Wet or collodion plates are only slightly affected by the X-rays. Great advantage is secured by employing double emulsified plates, the depths and contrasts of the images being brought out more thoroughly. The X-ray plate, which is always to be preferred to the ordinary plate, should be employed.

Owing to their flexibility, celluloid films can be brought in contact with any uneven part of the body. But if not handled with scrupulous care, the emulsion is liable to crumble. Other objections are their cost, their constantly varying sensitiveness, and the fact that they are not easy to manipulate.

The double-coated celluloid films are coated singly on each side, causing a reduction in time to the exposure of the rays; but they offer difficulties in development and by transmitted light present the blurred effect of both films. Both paper and celluloid films may be superimposed so that half a dozen or more may be simultaneously exposed to the rays. Bromide paper can be examined only by reflected light. This paper is cheap and does not necessitate first producing a negative; its use is not to be recommended, as a good picture never results thereby.

*Care of the Plates.*—Because of the extreme sensitiveness of the plates, they should be stored in places that are absolutely free from smoke, gases, excessive light, etc. The temperature of the room should be constant, sudden changes being liable to cause a condensation of moisture upon the coated side which in time results in "mildew fogging." The plate packages or boxes should be placed on their edges, thus avoiding undue pressure on the individual plates. As to the number of plates to be kept on hand, I recommend not more than a month's supply,—the operator, of course, must be governed by the amount of work he is doing. The plates should not be unpacked from the maker's cases and placed in the regular X-ray envelopes until needed,—this precaution guards against fogging of the plate. If the plates are to be stored in the laboratory where the X-ray apparatus is located, a wooden closet, carefully lined with sheets of lead, should be built, to avoid the damaging effects of the rays upon the plates. If stock plates are stored in an adjoining room, they should be protected against the rays in exactly the same manner.

#### A. DEVELOPERS.

A developer consists of four parts,—(a) reducer, (b) preservative, (c) accelerator, and (d) a restrainer.

(a) *Reducers.*—The best reducing agents are metol, pyrogallol,

eikonogen, hydrochinone, and rodinal. They all undergo easy oxidation; hence sodium sulphite is added as a (b) *preservative*. Combinations of the above are usually preferred. Regulate the action of the developer by the addition of an accelerator or a restrainer. If the reducer acts tardily, add the accelerator (carbonate of sodium or potassium). Too rapid developing with strong solutions is undesirable; it means lack of gradation, a forcing up of the high lights before the developer has had time to act on the less exposed parts of the plate. Ready prepared developers will not be suitable for skiagraphic plates. It should be remembered that the operator should adhere to one kind of developer and become thoroughly acquainted with its action. The following are the formulæ that I daily employ in my laboratory :

Water.....	100 ounces	(3000 c. c.)
Metol .....	120 grains	(8 grams.)
Hydrochinone .....	100 grains	(6.6 grams.)
Sod. sulphite (crystals).....	4 ounces.	(120 grams.)

or

Water .....	64 oz.	(1920 c. c.)
Eikonogen .....	1 oz.	(30 grams.)
Hydrochinone .....	$\frac{1}{8}$ oz.	(4 grams.)
Sod. sulphite (crystals).....	2 $\frac{1}{2}$ oz.	(75 grams.)

(c) *Accelerator*.—With either of these reducing solutions, it is necessary to employ, in conjunction, an accelerating solution, made up as follows:

Water.....	64 oz.	(1920 c. c.)
Potass. carb. (crystals).....	8 oz.	(240 grams.)
Sod. sulphite (crystals).....	2 oz.	(60 grams.)

The dry or anhydrous chemicals are about twice as strong as the crystals, and *vice versa*.

Combinations of hydrochinone with metol when too old should not be used, as they would cause the negative to present a "streaky" or "blotchy" appearance.

The one solution developer of rodinal is convenient and efficient, especially when employed for two-sided films or plates. This agent keeps well as long as the containers are kept filled and tightly corked.

With its use the image appears quite rapidly, but development must be continued until the film is so dense that no details are discernible when viewed by transmitted light. The following formula may also be employed :

Rodinal .....	1 part.
Water.....	20 to 40 parts.



An advantage of the ortol developer is that it may be repeatedly used, keeping perfectly well as long as the stock solution is kept in small bottles and tightly corked. Formula:

Water.....	60 oz.	(1800 c. c.)
Ortol.....	$\frac{1}{2}$ oz.	(20 grams.)
Potass. bromide.....	20 grains	(1.3 grams.)
Sulphite of soda (crystals).....	6 oz.	(180 grams.)
Carbonate of soda (crystals).....	5 oz.	(150 grams.)

For use: Dilute one part of the above with two to four parts of water, according to the density desired.

(d) *Restraining Solution*.—Ten per cent. solution of potassium bromide kept in a tightly corked bottle. (Pipette and dropper are useful adjuncts in the handling of this solution.)

*Tropical Developer*.—For hot climates where no ice is available.

Water.....	50 ounces	(1500 c. c.)
Sulphite of soda (crystals).....	2 ounces	(60 grams.)
Bromide of potassium.....	20 grains	(1.3 grams.)
Citric acid.....	20 grains	(1.3 grams.)

For use: To 4 oz. of the above solution add 10 grains of dry amidol. Before developing place the plate in

Water.....	60 parts,
Formalin.....	1 part,

for about three minutes, rocking the tray occasionally, then rinse well and place in the developer.<sup>1</sup>

## B. MODUS OPERANDI OF DEVELOPMENT.

After the plate has been properly exposed it is taken to the dark room, the envelope opened, and the plate removed. (After having been exposed, it should not be allowed to remain in the exposing room, if another case is to be skiagraphed.) Place the plate, gelatine side up, in a tray of sufficient size, and pour on the developer. For development of

<sup>1</sup> Henry Hulst (Transactions of the American Röntgen Ray Society, 1905) says: "The developer which I use for exposures of one second or less in chest work, I use for calculi as well. It is as follows:

Potassium carbonate, dry.....	12 dr.	(48 gm.)
Sodium sulphite, dry.....	6 dr.	(24 gm.)
Potassium bromide (10 per cent. sol.).....	2 oz.	(59.2 c. c.)
Hydrochinone.....	4 dr.	(16 gm.)
Water.....	1 qt.	(1 litre.)

"If the high lights begin to show before 40 seconds, from two to four ounces more of the potassium bromide solution are added. Development should be complete in four minutes."



the plate, take four (4) parts of either reducing agent, above mentioned, and about one-half ( $\frac{1}{2}$ ) part of the accelerator solution. If the image does not appear in half a minute, add another portion of the accelerator. Thus cautiously add at very brief intervals small quantities of the accelerator, and the image will be better evolved than if an excess of the alkali be added to the reducer at first. Start at one corner, and with a single sweep, pour on sufficient solution, rocking the tray to secure thorough immersion and evenness. To splash the solution is to produce air bubbles, and the latter will form spots on the negative. Should air bubbles be detected, touch them lightly with a pledget of cotton.

For development of a special make of plate, follow the directions on the box. Observe all changes going on in the plate. After the plate has been developing for a minute or longer, lift it from the tray and examine it by transmitted light to see how far the process of development has advanced. This is dependent upon the time the sensitive plate was primarily exposed to the action of the rays, to the thickness of the part under examination, the type of plate, and also upon the temperature of the developer and the dark room. I always judge the density by transmitted light, deeming this preferable to the reflected picture from the sensitive side. Another method is the appearance of the picture on the glass side or back, showing the reduced metallic silver deposited on the glass. It will take a longer time to develop a plate of the lungs, pelvis, abdomen, or the denser parts of the body than it does of the hand or foot. For the former structures keep the plate in the developer until the whole surface is uniformly blackened and very little light is transmitted. In the fixing bath the proper degree of density will be produced. To strongly contrast the bony and fleshy structures of a part, reduce the time of development or dilute the developer; the result will be a "soft negative." The necessary density may be obtained later by intensification. For a good negative, start with weak developers and gradually increase the strength by adding stock solutions (the reducer). In order to bring out the details with greater delicacy, some prefer to use first a suitable hydroquinone developer, to effect sufficient density, and then transfer the plate in rodinal or metol developers. When the plate is sufficiently developed, put it in a trough of running water or under a stream from a spigot, always seeing that the gelatine side is up, and that it is not liable to get scratched by any contact with the spigot or other body. Continue the washing for at least two minutes.

The denser the structure, the less will be the oxidation of the emulsions, and consequently the later the appearance of the part on the plate. If structures of different densities appear simultaneously on the plate, it signifies over exposure; in that case, pour off the developer, and substitute a fresh, weak developer. It should be remarked that the developer

must not be diluted, as it makes development slow, and the negative will be soft; this is especially true of the thick parts; instead put in less of the accelerator (sodium carbonate). During the summer, put ice into the developer, or put the developing pan into a tray of ice-water. Temperature of the developer should be 65° or 70° F. (18° to 21° C.). Over exposed plates should not be removed quickly from the tray, as the developer will not have time to penetrate sufficiently deep to affect the lower layers of emulsion; although the upper layer by its darkening may deceive the operator.

If the image appears slowly,—*i. e.*, within a minute or two,—it signifies *under exposure*; in this case tilt the solution to the corner of the tray, and add some of the accelerator. If after this addition and sufficient development, the desired density is not obtained, pour off and wash the plate, and employ a fresh developer.

Of late years the "tank" or slow developing process, has been used by some skiagraphers. The tank development is to be recommended for plates which have not received full exposures and for the smaller size plates. It is claimed that the length of time to which the plate is subjected to comparatively weak developing solution (40 to 60 minutes), will bring out much more detail than the application at once of a more vigorous developer. However, for fully timed plates, I would prefer the methods recommended above. The following is Mr. Cramer's formula :

## STOCK SOLUTION.

Water.....	32 oz.	(1000 c. c.)
Carbonate of soda (dry).....	2 oz.	(62 grams.)
Sulphite of soda (dry) according to desired color of negative.....	1 to 1½ oz.	(32-48 grams.)
Bromide of ammonium.....	30 grains.	(2 grams.)
Citric acid.....	30 grains.	(2 grams.)
Hydrochinone.....	1 dram.	(4 grams.)
Glycin.....	2 drams.	(8 grams.)
Metol.....	2 drams.	(8 grams.)
Pyro.....	4 drams.	(16 grams.)

Dissolve the chemicals in given rotation.

To preserve the stock solution, we recommend filling small bottles of the exact size to hold just enough for making the diluted solution for the tank. The bottles should be quite full and tightly corked.

## FOR USE:

Water.....	120 ounces.
Stock solution.....	6 ounces.

The developer should be used fresh, and its temperature kept between 60° and 65° F., until development is completed.



FIG. 106.—Envelo developer. (Lyon Camera Co.)

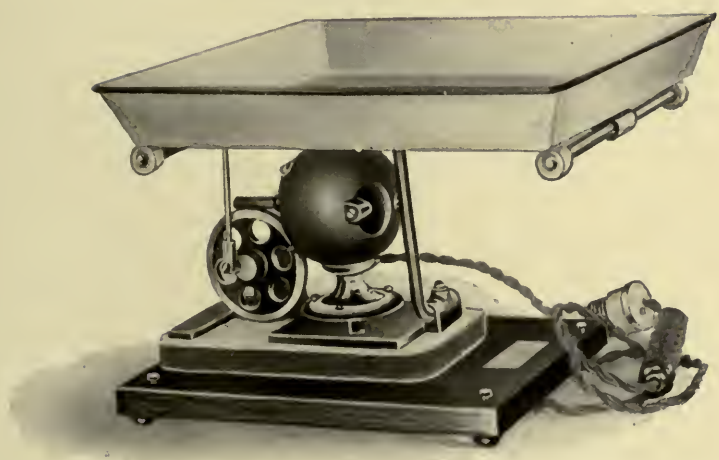

FIG. 107.—Automatic tray-rocker. (Röntgen Manufacturing Co.)





It is necessary to observe the following rules in handling the developer:

No. 1. Immerse the plates in a tray of cool water before putting them in a tank.

No. 2. Immediately after immersing the plates in the tank solution, move the plates up and down with a quick motion, to prevent air-bells or bubbles forming on the surface of the film.

No. 3. After the plates have been in the tank from five to ten minutes, lift each plate out of the tank and reverse its position, by placing that end of the plate which was at the top of the tank to the bottom. This will prevent the appearance of streaks, which are sometimes found in tank development.

No. 4. It is well to rock or shake the tank, at least once in every five minutes, during development. This often prevents the appearance of streaks or spots in the negatives.

The Envelo developer (Fig. 106) is an extremely simple device, designed to develop two plates at one time, by the tank or stand method. It is constructed of metal, heavily nickered on the outside, and coated on the inside with a liquid proof composition.

When the plates are large, and slow development is aimed at; in order to save time, resort may be made to the tray-rocker (Fig. 107) which works automatically through the agency of an electric motor.

*Fixing.*—After development, the plate is washed in the tray with running water, instead of the usual method of washing it, when removed from the tray. This prevents breakage of the plate and likewise contact with the developer, which would cause irritation to the fingers.

The process of fixing dissolves out all the silver bromide unacted upon by the light or developer. Allow the plates to remain in the fixing bath for three to five minutes, after the chemical agent has been completely removed; this will insure permanency, freedom from stains, and perfect hardening. After all "whiteness" has disappeared from the glass side, bring "the negative" to the light. Leave it five minutes longer in the solution, to allow for thorough fixing, as this plate has a thick double coated emulsion.

*The acid chrome fixing bath* I largely employ, as it does not discolor and keeps longer than the plain hypo fixing solution. It is made as follows:

Water.....	100 oz.	(3000 c. c.)
Sulphuric acid.....	3 oz.	(90 c. c.)
Sulphite of soda.....	4 oz.	(120 grams.)
When dissolved, add—		

Hyposulphite of soda..... 2 lbs.

Dissolve, and add—

Chrome-alum, from one to two ounces, previously dissolved in 20 ounces of water. Follow by adding water to make a total of 160 ounces.

In hospitals and large laboratories it is useful to employ two large wooden boxes that act as tanks. (Fig. 108.) In the Philadelphia Hospital I have these boxes divided into different sized compartments to accommodate the various sized plates. Each compartment has six vertical grooves, for holding six plates. One of these tanks contains the acid hypo sufficient for six months' use. The other tank is similarly constructed, in which the water enters at the bottom and circulates to the top, and then overflows into a discharging pipe.

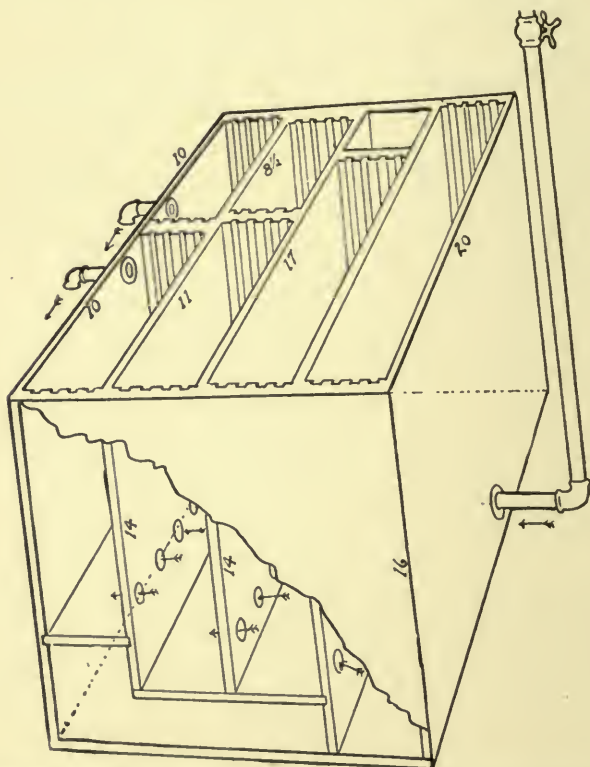

FIG. 108.—Author's washing tank. The fixing tank is similar in construction.

*Washing.*—After fixing, washing must be quickly and thoroughly done. One hour's washing with running water is sufficient; if the supply be not so accessible, place the negative in a flat dish and constantly rock for five or ten minutes. Change the water and repeat the process for one-half to three-quarters of an hour. Remove the negative, again wash under the spigot, using a pledget of cotton to wipe off any foreign particle adhering to the gelatine coating.

*Drying.*—Dry the negative in a room of moderate temperature, in which a ventilator supplies plenty of air. Do not dry in the sun, as



sunlight produces softening and increases the density of the film. To dry a negative hurriedly,—*i. e.*, in five or ten minutes,—lay it in a bath of alcohol after washing thoroughly, or put before an electric fan.

The negative must be *completely dried* in one room. To take it partially dried into another room and there complete the process, will result in the finished negative offering a difference in densities. During the summer season the negative becomes denser than in winter.

*Hardening.*—After fixing the negative, wash and place it in the following :

Water .....	4 ounces	(120 c. c.)
Formaldehyde.....	1 ounce	(30 c. c.)

Keep in this solution from five to ten minutes, rocking the tray from time to time. If the solution is made too strong the film may peel off. If hardening is done before the fixing, then the fixing process should require more than usual time. This will frequently be of necessity in hot climates and during the hot seasons in temperate climates.

### C. IMPROVEMENT OF THE NEGATIVE.

*Intensification.*—This process with proper exposure and development is seldom required, except for special purposes, *i. e.*, for under exposed or under-developed plates. The negative is first well washed and then placed in the following :

Mercuric bichloride.....	200 gr.	(13.3 grams.)
Potassium bromide.....	120 gr.	(8.0 grams.)
Water.....	6½ oz.	(200 c. c.)

Keep the plate in this solution a short time, when it will be observed to be bleached uniformly white, assuming the appearance of a positive ; the longer the negative is bleached, the denser it will become. It is again thoroughly rinsed and washed under the spigot for at least a half hour in running water, and then blackened in the following solution :

Sodium sulphite.....	1 oz.	(30 grams.)
Water.....	4 oz.	(120 c. c.)

or

Ammonia .....	20 min.	(1 c. c.)
Water .....	1 oz.	(30 c. c.)

It now being blackened, it is again washed, followed by drying. The least yellowish cast indicates that the negative has not been washed sufficiently after the bleaching. The prints of such negatives show the soft tissues very faintly, producing a great contrast, and on account of their great density they print very slowly.

*General reduction* is used when the negative is very dense, as a result of over exposure, over development, or where there is an excessive amount of alkali present in the developer. To correct this use the following solution :

A.—Water .....	16 oz.	(500 c. c.)
Hyposulphite of soda.....	1 oz.	(30 grams.)
B.—Water.....	16 oz.	(500 c. c.)
Potass. ferricyanide .....	1 oz.	(30 grams.)

Mix 8 parts of solution "A" and one part of solution "B," and use in subdued daylight.

The negative can be placed in this solution directly after fixing. If a dry negative is to be reduced, it must be soaked in water for at least half an hour, before applying the solution. To avoid streaks, always rinse the negative before holding it up for examination. As soon as sufficiently reduced, wash thoroughly. When not in use keep solution "B" protected against the action of light.

A gradual uniform reduction will take place, its rapidity, of course, depending upon the quantity of potassium ferricyanide added. When sufficiently reduced, wash and thoroughly dry. To reduce locally, apply carefully with a brush or cotton some of the solution on the wet negative, allowing it to remain until sufficiently reduced; follow by thoroughly washing and drying.

The other reducing agent consists of persulphate of ammonia in water. One part to forty is strong enough for most purposes ( $\frac{1}{4}$  oz. to 10 ounces). This solution does not keep well, and should be made as required. Its action on the plate must be carefully watched—it acts slowly in the beginning, and then all of a sudden very rapidly. After sufficient reduction, rinse thoroughly, and place in a 10 per cent. solution of sulphite of soda. Wash well again and dry.

There is a great difference in the action of these two reducers. Potassium ferricyanide, like most reducers, attacks the fine details more readily than the denser parts, the negative becoming harder and thinner. The persulphate reducer, on the contrary, appears to reduce the denser parts more in proportion, so that the negative becomes slightly flatter.

*Local Reduction.*—This consists of bringing in contact with a certain part of the negative some reducing agent, destroying contrast to some extent. Let us suppose a negative having a printing effect of faintly bringing out the fleshy part and deeply the osseous part; should we desire to bring out more heavily the fleshy part, we employ what is termed the local reducer. To place this only on the "fleshy" part of the negative requires a great deal of skill—the effect being to further

reduce the silver salt, thus giving more chance for the rays of light to penetrate the negative and printing the paper more heavily. The best results in local reduction can only be obtained by constant practice. In local reduction the plate must be previously wet, as otherwise a streaked appearance will result.

*Causes and Prevention of Faulty Negatives. Fogging.*—A total blackening of the plate under development is distinguished from other types of fogging in that the former remains clear at its edge. Fog also results from a developer containing too much alkali, too high a temperature, or exposure to other rays than those emanating from the Crookes tube. Improper or too much light in the dark room also causes fogging. General fogging cannot be remedied; the negative, however, may be sufficiently cleared by a reducer, followed by intensification.

*Stains.*—Deep yellow, orange, or brown stains appearing gradually either in patches or all over the plate may result from imperfect fixing or incomplete washing after fixing. Another cause for these stains is decomposed hypo in the film by improper washing, or the use of alum or acids. Over developing frequently causes greenish stains (excess of reducing agent).

*Spots.*—Spots or pin-holes in negatives are usually due to air-bubbles and decomposition of the films. Small clear spots generally result from dust particles. Another type of transparent spot, irregular in shape, results from the scum of the developer. This is only seen on the surface of very old developers. Sediment, accumulating in the trays, graduates, and solution bottles, may come in contact with the film, thus interfering with the action of the developer, the result being spots. Particles of undissolved developer (pyrogallol) adhering to the film produce irregular dark spots. Cleanliness in all the steps of the developing process is the only preventive against the formation of spots.

#### D. PRINTING (POSITIVE), TONING, AND MOUNTING.

The X-ray image of the negative may be printed on paper as in ordinary photography. All diagnoses, as far as practicable, should be made from readings from the negative instead of from the print. There are instances, however, where information may be gained from the print which inadvertently had been overlooked in the interpretation of the negative. Another advantage in using the print is that it may be passed among a class of students for study, a procedure that might endanger a valuable negative. A properly exposed and well developed negative usually serves to produce a good print on almost any reliable paper. The commonest printing-out paper used in this work is the ordinary



“albuma,” the printing of which is conducted by sun-light. The advantage of this paper is that the strength of printing process may be easily controlled.

“*Dodging*” is a method employed for reducing inequalities of a print from a good negative. We can best understand this method by citing an example. Let us take a negative of the hand; it is placed in a regular printing frame as already referred to. We are all aware of the fact that the carpo-metacarpal part of the negative has been reduced by the developer to a less extent than the phalangeal portion. Therefore in the print the former portion would be shown more strongly than the latter, because more rays can come in contact with the paper. In order to equalize the print, we “dodge” the carpo-metacarpal portion of the hand by constantly moving a piece of card-board above it,—*i. e.*, we shield it against further action of the light rays. This permits of the phalangeal portion being printed to the extent desired. Were we to cover the carpo-metacarpal portion by laying card-board over it, without moving it, a dividing line would be readily discernible, being exactly the opposite of what we desire to achieve.

*Ground-Glass Substitute.*—The glass surface of the plate is cleaned of all dust particles, finger marks, etc., and a solution of certain gum resins in ether called ground-glass substitute is poured evenly over the surface, precaution being exercised to prevent the liquid from coming in contact with the film. The ether evaporates more rapidly, leaving behind an even coating of gum resin, which, adhering firmly, gives a ground glass appearance. The negative may now be “evened up” by daubing burnt umber into the gum layer corresponding to those parts which are “thin.” To even up a negative requires skill, and in order to guard against any errors I advise the use of a print from the negative before it has been prepared, thus acting as a guide. If the negative is uneven, scrape the ground-glass substitute from those parts that are too opaque to the rays, thus allowing of the easy passage of the latter. Soft negatives should be printed with tissue paper over the printing frame. With a little practice, the inexperienced will rapidly learn the art of developing. It is better that he do this work himself than to rely on the services of professional photographers.

*Developing Papers.*—Velox and bromide papers can only be printed in dark rooms by artificial light, the sensitized surface of the paper being placed against the gelatine side of the negative, and the printed image is brought out by a process of developing. The advantage of these papers is the rapidity with which the printing is done without the aid of sunlight. The time of exposure to artificial light can be ascertained only by following the directions and by experience. Velox and bromide paper should be developed according to the “instructions” accompanying each package.

*Toning Process.*—Albuma paper, after being printed, should be trimmed, and then washed in running water until it ceases to be “milky.” The prints should now be placed face to back, one upon the other, and introduced into the toning solution. The lowest print is then removed and placed upon the uppermost, continuing this process for some time.

## TONING SOLUTION.

Chloride of gold.....	20 gr.	(1.25 grams.)
Acetate of soda.....	1 oz.	(30 grams.)
Water .....	20 oz.	(625 c. c.)

Keep slightly alkaline by frequently adding sodium bicarbonate. Of the stock solution take an ounce, dilute it with ten ounces of clear water; it is then ready for use.

Put the prints into this solution; keep them moving, thus insuring even toning. If the toning be too slow, a few drops of the stock solution should be added to the diluted toning solution. On the other hand, if the toning is too rapid, a small quantity of water should be added. Usually from 15 to 20 minutes are required to bring out an even and proper tone. After the toning process is completed, the prints are thoroughly washed for some time in running water. The prints are next introduced into a fixing bath which consists of

Hyposulphite of soda.....	2 oz.	(60 grams.)
Water.....	20 oz.	(600 c. c.)

In this solution they should be allowed to remain for at least 15 or 20 minutes, keeping them in motion. All these processes should be conducted in a dimly lighted room.

*Mounting.*—After the prints have been thoroughly fixed, they are again washed for several hours in running water. They are next placed separately on a plate of glass (face downward) before drying, and all the wrinkles are rolled out by blotting paper. The back of each print is now painted with photographic paste and mounted on stiff card-board. Blotting paper is placed on the face of each print, and a roller used before the print has dried, to remove any wrinkles.

*Positives.*—Another method of printing consists in placing the X-ray negative into a regular printing frame, and a sensitive plate behind it. Everything being in total darkness, light a match and expose the plate for 5 or 8 counts. Develop the plate in the usual manner, the result being a “*positive*.” These positives are the exact size of the negative (contact print), while transparencies and lantern slides are reduced in size. If prints are made from these positives, the bones will appear white, the fleshy parts dark, etc., similar to the appearance of the original negative.

*Transparencies and Lantern Slides or Diapositives.*—The reduced transparencies appear with fuller detail and are easily handled and convenient for exhibiting purposes. The reduced transparency can be obtained by putting the original negative in a camera or window, the negative being transilluminated and focused over a 4 x 5 inch (10 x 12.5 cm.) sensitive contrast plate and developed. If a smaller sized plate be used, 3½ x 4 inches (8.2 x 10 cm.), we obtain a lantern slide for projection. In making prints from these negatives, the bones, for example, will appear white, a circumstance that will often prove useful.

Batelli and Garbasso were the first to suggest the wisdom of obtaining reduced photographs, from images observed on the fluoroscopic screen, the advantage being that small-sized plates may be readily employed. But certain disadvantages of the method at once present themselves. The image on the screen must be steady, and there is required an ortho-chromatic plate, with a long exposure, as the image formed is yellow in color. The process is not well developed as yet, but when it is, an additional precaution will be the protection of the camera from the rays.

#### IV. Interpretation of X-ray Negatives.

This is more difficult than making the negative, because of the superimposition of shadows of varying densities. The trained eye of the X-ray specialist alone, can indisputably interpret the negative with any degree of correctness.

The negative should be a satisfactory one of the special structures under examination. If it is found to be unsatisfactory, a duplicate should be made; if this is not easily procurable, the negative can be improved by the process that I have mentioned in the chapter devoted to photography. In those cases where difficulty is encountered in arriving at a positive diagnosis it is imperative that a duplicate be made in order to confirm the earlier diagnosis.

A blurred negative cannot be remedied and is in every way inferior to an under- or an over-exposed plate.

The skiagrapher should keep full data of the technic when making the negative. He should always endeavor to interpret it correctly and to compare it with a negative of the corresponding part in the same individual; he should study each part and its anatomy, and make himself thoroughly informed upon every subject that comes to him for diagnosis and opinion.

*How to View the Negative.*—It is of prime importance to know the exact relations of the tube and the position of the part to the plate.

The X-rays emanate from a small point on the anode, diverge, and then traverse the object, casting enlarged shadows on the fluoroscope or



plate. The collections of silhouettes are therefore superimposed—*i. e.*, there is a composite of the shadows of the object near the tube and those near the plate. When a negative is dry and ready to be examined, the eye of the skiagrapher or observer should take the place of the anode of the Crookes tube, the film or gelatine side facing the interpreter's eye, equal to the distance of the tube from the plate.

Suppose that the right palm is in contact with the sensitive side of the plate, when examining the negative, it follows that the negative will be seen when the gelatine side is toward the observer's eye; but if the observer's eye corresponds to the Crookes tube, then the dorsum of the hand will be brought into view. On the contrary, with the glass side toward his eye, the observer views the dorsum of the left hand or palmar view of the right hand, which is equal to the fluoroscopic view or a print. For instance, a patient is in the dorsal position, the plate placed against the back and the tube over the sternum, with the gelatine side (film) toward the observer's eye and the eye corresponding to the Crookes tube; then this negative will show as though the observer were looking through the anterior wall of the thorax; the left side of the patient will be his right side and *vice versa*.

If you examine this negative with the glass side towards your eye (which is equal to placing the fluoroscope to the back, or looking at a print) the right side of the patient will be your right side, etc.

If a ventral or anterior view is taken, place the plate in front of the chest and the tube posterior; when this negative is examined (film side towards the eye), the patient is viewed through the back, his right side will be your right side, etc., but if you look at the glass side of the negative, then this will be equal to the fluoroscopic view or a print, *i. e.*, the patient's right side will be your left side, etc.

I prefer to make the examination or interpretation directly from the negative and not from the prints, because prints reverse the views. If we look at prints of the anterior view of the thorax, our eyes do not correspond to the anode of the Crookes tube, but we are looking at the front of the chest and rays are coming through the back of the patient; we call this the ventral view, etc.,—*i. e.*, the view or part that is next to the gelatine side of the plate, the fluoroscope, or print, or its equivalent to the negative glass side toward our eyes. The negatives should be placed or held with the gelatine side toward the examiner's eyes, because in this position, we look through the object and see its shadows more correctly and truer in their relation to each other. There will likewise be no reflection of light from the film, as there will be from the glass side. The negative can be held by the examiner who manipulates it, by viewing it from different angles, or an assistant holds the plate and the operator examines it from different distances and angles.

A better plan is to place the negative in a window, lower the curtain, and allow the light to come through the negative. I often prefer to place the negative in the window of the dark room and examine it either alone or by a similar negative of the corresponding part of the same person; if this be not possible, I employ the negative of some other person and then compare them side by side. Another easy method is to place the negative in a photographer's retouching desk, which is so very convenient for small negatives.

I have devised a viewing box (Fig. 109) which I employ at the Philadelphia Hospital. This box accommodates any sized negative and is capable of rotation, and thus without any displacement the negative can be viewed at any angle and also in the vertical or horizontal position.

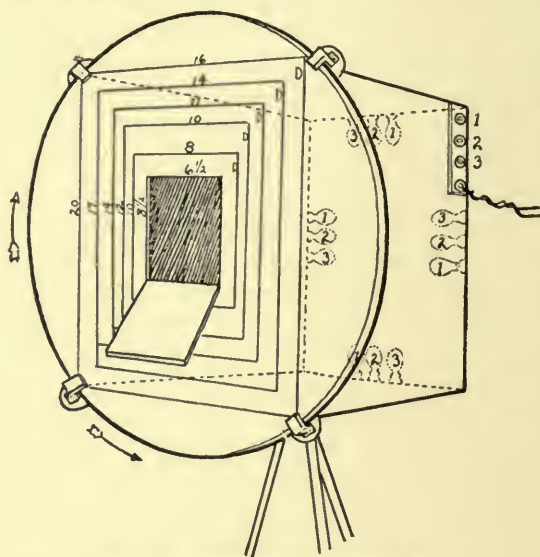

FIG. 109.—Author's negative-viewing box.

This box contains three series of eight c. p. lights behind the ground glass. When a dim or weak light is desired for less dense negatives, one series of lamps is lighted; if strong light is desired, the No. 2 switch is turned on and greater illumination is produced. This box contains perforations and is lined with asbestos. The preferable light for the examination of negatives is white (day) light or the electric light. The intensity of the light can be regulated by the interposition of either ground glass or a rheostat, as necessity requires.

#### A. FOREIGN BODIES.

In interpreting a negative for a foreign body, exclude all possible errors, such as white spots produced by air bubbles during development,

the presence of iodoform, lead water and laudanum, etc., that may be on the bandage or dressing. Metallic foreign bodies will eclipse all other shadows. When semi-opaque bodies cast their shadows on those of the bones the contrast may be only very slight, especially so, when the plates are undeveloped. Small bodies in the deeper portions of the body (as for instance in the abdomen and in bony cavities, as the eye) may defy detection if the time of exposure is prolonged and secondary rays produce fogging on the plate. This occurs especially when the foreign body is non-metallic,—*i. e.*, a fragment of stone, etc.

## B. FRACTURES AND DISLOCATIONS.

Green-stick fractures and impacted fractures are often difficult to recognize. If the rays do not penetrate the separated fragments, the shadows will be superimposed, and the characteristic dark line on the negative will not be visible; in impacted fractures instead of this dark line there will appear an increased white shadow. Epiphyseal lines should not be lost sight of. The elbow-joint in children should be compared with the corresponding normal side.

*Fractures of the Hip-Joint.*—In these fractures note the changes occurring, even if the dark line on the negative is not visible; and also look for any change in the continuity of the periosteum, the shape and relation of the femoral neck to the trochanter, etc. Compare the normal hip-joint with the affected one, and take a skiagraph of both hips on one large plate, being careful to observe the position of the feet.

*Dislocations.*—This condition can be discerned easily. The relations of the heads of the bones may often be disturbed or changed either by a peculiar position that the part may assume, or by a faulty relationship in the position of the tube to the plate; this frequently occurs in the shoulder-joint, in the acromio-clavicular articulation, etc. Intra-articular cartilages are transparent to the rays and may thus be mistaken for a dislocation.

The ventral and dorsal positions of the shoulder-joint present different appearances on the negative.

## C. DISEASES AND TUMORS OF THE BONES.

It is important to determine if the growth is osseous or of muscular origin. Whenever possible the shadow should be cast in the light field, and note should be made whether the shadow is attached to the periosteum or to the central portion of the bone. Do not diagnose the bony normal ridges, grooves, or projections as irregularities of the compact portion of the bone. The early stages of any special bone disease are differentiated with difficulty from other osseous diseases by the appearance



offered on the negative, as nearly all bone affections produce an increase in shadow density. Such a negative may assist the physician as to the origin and the exact location of the disease, and as the disease advances the characteristic appearance of that particular disease of the bone on the negative will be noticed.

*Callus.*—The appearance of callus can be diagnosed from periostitis, or other diseases, by the deformity produced and because the shadows are fusiform and encircle the ends of the fragments.

*Diseases of Joints.*—Endeavor to obtain an intra-articular space as wide as possible. Bandages and dressings should always be removed. Ordinary arthritis is differentiated with difficulty from the other arthritic affections in their early stages. Pus and fluid, whether serous or purulent, cannot be easily differentiated, although serum casts a denser shadow than pus.

Intra-articular inflammation with exudation, can be differentiated from a periarticular inflammation, because the intra-articular space of the former is increased on account of the tension exerted.

False and true ankylosis should be carefully differentiated. Bony ankylosis may be excluded by the absence of dense shadows, or by the obliterated intra-articular space, which is absent in false ankylosis. In advanced cases deposits of tophi are demonstrable, and one can observe with certainty whether the disease is intra-articular or periarticular in origin.

In hip-joint disease or in any other disease of the bone or joint, the true conditions or size of the bone may be altered, diminished, or increased, either by being nearer to the plate (as the result of atrophy of the muscle from disease), by disuse, or by other causes that may exaggerate the normal size of the bone on the negative.

#### D. DISEASES OF THE SOFT STRUCTURES.

It is very difficult in these conditions to skiagraph or to obtain a clear shadow on the negative, and even when once obtained it cannot be differentiated from similar conditions, as lipoma, sarcoma, cyst, etc. A soft negative, full of details, is most desirable, and may be easily obtained by slightly under-developed and properly exposed plates.

Brain tumors are very difficult to diagnose. Thickness of hair, especially in female subjects, should not be mistaken for a neoplasm.

#### E. DISEASES OF THE THORACIC ORGANS.

Negatives of the thorax should be examined in a viewing box. The skiagrapher should be familiar with the fluoroscopic appearance of the normal and of the pathological lung. The physical examination should always precede the skiagraphic examination. When the plate is placed

over the anterior wall of the thorax, the negative will reveal the cage-like appearance of the thorax; the anterior portions of the ribs will appear sharp and distinct, and will form an angle with the posterior portion.

If the negative has been exposed in contact with the back of the patient, then the posterior portion of the ribs will be more distinct than the anterior portion, the latter being further from the plate. If the time of exposure is prolonged, these anterior portions of the ribs will be indistinct and widely separated. The shadow of the diaphragm will be more distinct on the affected side, being less mobile during the exposure.

In comparing the transparencies of the apices of both lungs in right-handed persons, the right side may appear lighter on the negative.

In viewing the anterior wall of the chest examine the intercostal spaces; do not mistake the shadows of the anterior portion of the first rib (often cast between the 2d and 3d intercostal spaces), or the sternal end of the clavicle (which may show an increased shadow), for consolidation. The shadows of the sternum require most careful observation and the shadows of the scapula will often be cast outside of the thorax. The female mammary glands throw pronounced shadows.

In the incipient stage of tuberculosis, the apices of the lungs must be studied with great care, as a slight degree of congestion or infiltration will throw a shadow on the affected side. If one apex is diseased, the diagnosis will be arrived at with less difficulty, because an opportunity is afforded for comparison with the normal apex. Do not compare the transparency of one apex with other portions of the lung, but apex with apex, etc.; for as the thickness of the thoracic wall differs in different parts, so does the transparency vary in the same person.

Bronchial or lymphatic glands when calcified (and which are tuberculous), can often be observed without difficulty; small areas of consolidations will appear as irregular scattered light patches. Longitudinal streaks on each side of the heart are supposed to be due to the foldings of the pleura, when the latter are viewed edge-wise. Upon the negative the posterior view shows the ribs very clearly and distinctly, and likewise the vertebrae. The anterior portions of the ribs, however, are blurred, because the posterior ribs are nearer to the plate and are immobilized.

Abscesses and empyema do not cast shadows so dense as does consolidation; neither do the former obscure the shadows of the ribs. Pleural thickening is differentiated from effusion in that the latter casts a uniform and more dense shadow; the level of the shadow will change with the position of the patient and is best viewed in the erect or sitting posture. In thickening of the pleura an irregular outline is discernible.

In *consolidation* the shadows are larger, more irregular, and denser than those cast by the ribs, and especially noticeable in advanced cases

of tuberculosis. The apex alone may be affected, but in other instances the entire lung is attacked. It is thus that consolidation is differentiated from effusion.

*Cavitations* are characterized by dark areas surrounded by a light field; this is due to a lessened amount of tissue for penetration by the rays. If the cavity is partly filled with fluid while the patient is in the recumbent posture, the fluid gravitates, and the dark area is obliterated; but in the erect or sitting posture the level of the fluid will be visible when it is of considerable size.

Prior to a paroxysm of severe coughing, if a fluoroscopic or skiagraphic examination be made with the patient in a recumbent position, and another examination taken subsequent to the paroxysm, the cavity will be noticeable, because the fluid, pus, etc., will be evacuated.

*Emphysema* is manifested by excessive darkness on the negative, due to the presence of air in the lung, as is also observed in cases of pneumothorax, etc.

The shadows of the ventricles, the auricles, and the aorta are easily recognized; for a detailed account, the reader is referred to the chapter devoted to the Circulatory System.

I have made stereoscopic skiagraphs of the thorax which are very useful in differential studies in pulmonary and cardiac affections.

#### F. ALIMENTARY SYSTEM.

Stricture of the œsophagus, whether due to a growth within or external to and compressing the œsophagus, is difficult and often impossible to differentiate by the skiagraphic appearance; but if the growth is within the œsophagus and the latter cannot be dilated, it becomes necessary to introduce an œsophageal bougie; on the other hand, if the growth is external, the sound can be introduced by displacing the growth to one side.

*The Stomach.*—The reader is referred to Chapter V., Alimentary System.

#### G. GENITO-URINARY SYSTEM.

Only in emaciated individuals are the shadows of the kidneys easy of demonstration. In the normal individual, shadows of the kidneys as seen on the negative are very unsatisfactory.

Renal calculi should not be mistaken for biliary calculi, intestinal concretions, enteroliths, tuberculous foci, or abscesses. Scars and accumulations of sand in the pelvis of a kidney may in some cases cause an erroneous diagnosis to be made. I once mistook an undissolved capsule of bismuth for a calculus, but a second negative showed the change in the position that the capsule assumed, and the operation was postponed.



Dr. Henry Hultz<sup>1</sup> reported a case in which fracture of the transverse process of a vertebra would have been mistaken for a calculus had he not made a stereo-skiagraph of the condition. Whether a calculus is in the lower part of the ureter or in the bladder, is often a difficult matter to decide.

There are three methods for ascertaining the exact location of a calculus. 1. By inflating the bladder, when the shadow cast will be darker on the negative. 2. By injecting water, when the shadow will be seen to be lighter than the surrounding structure. 3. By introducing a catheter, when the presence of a (small) stone in the ureter will be noticed by its position, and relation to the end of the catheter. By the first and second methods the relation of the calculus to the bladder will be observed.

Several small round white spots often mistaken for calculi may be noticed along the left line of the ureter. They are frequently situated in a curved line and are more frequent on the left side than on the right, or sometimes on both sides of the same patient. They commonly occur after the thirtieth year. Their true nature is a disputed matter. Some believe them due to the presence of sesamoid bones in one of the obturator tendons.<sup>2</sup> Russell H. Boggs is of the same opinion; others incline to the belief that they are calcified glands.

Dr. Joseph F. Smith,<sup>3</sup> of Chicago, believes that in 25 per cent. of his cases negatives of the pelvis contained from one to six small round shadows, sometimes on one side, sometimes on both sides, in the vicinity of the ischium. He found, by dissections of cadavers, that these shadows are caused by small bony deposits that occur in the pelvic ligaments, especially in those attached to the spinous process of the ischium. I concur with those who believe that these spots are phleboliths. Among the latter may be mentioned Chas. L. Leonard, Henry K. Pancoast, and Max Reichman.<sup>4</sup> These shadows can be differentiated from those of ureteral calculi by passing a metallic bougie and by skiagraphing *in situ*. If these shadows are outside the shadow of the catheter, they are evidently not ureteral. The autopsy of one of my cases showed the presence of a phlebolith.

*Vesical Calculi.*—The shadows of the sacrum and coccyx may be superimposed by the shadow of a small calculus, hence the shadow of the latter may fail of differentiation. This is also true of the shadow of impacted fecal matter in the rectum. The bladder should be evacuated just prior to the X-ray examination, as water offers a barrier to the

<sup>1</sup>Transactions of the American Röntgen Ray Society, 1906, page 158.

<sup>2</sup>E. W. Caldwell, Medical News, April 22, 1905.

<sup>3</sup>Transactions of the American Röntgen Ray Society, 1906, p. 157.

<sup>4</sup>Fortschritte a. d. Gebiete der Röntgenstrahlen, Feb. 22, 1906.

passage of rays. I have frequently seen the outline shadows of the bladder, which are so valuable in determining whether the calculus is ureteral or vesical, or if the appearance is due to an interfering shadow.

In stricture of the urethra, by the introduction of a bismuth solution we are enabled to ascertain the location of the stricture, its calibre, etc.

A report of the X-ray negative should be written or oral and should be most carefully executed. The report should be made as intelligible as possible, by making some tracing, marking, etc.

There are numerous shadows on the negative that defy all efforts at interpretation and are as little understood to-day as they were when skiagraphy was first presented to the notice of the medical profession.

## V. Stereo-Fluoroscopy and Skiagraphy.

### A. HISTORY AND PRINCIPLES.

The application of the principles of stereoscopy to skiagraphy was first employed in this country by Professor Elihu Thomson<sup>1</sup> and subsequently used abroad.

Ch. Bouchard<sup>2</sup> claims priority of the discovery for Imbert and Bertin, of Montpellier, France, but this is erroneous, as the latter first made known their studies in *Comptes-Rendus*, March 30, 1896.

Dr. Mackenzie Davidson was perhaps the first investigator to produce and interpret X-ray photographs by this method, publishing an article in the *British Medical Journal* in 1898.

Professor G. P. Girdwood, of McGill University, Montreal, Canada, made extensive use of this method in studying foreign objects. The leading scientific journals of Germany have published many articles on this subject, describing the methods, the apparatus, and detailing advantages gained by its employment.

In October, 1901, Dr. Louis Weigel, of Rochester, exhibited a stereoscopic outfit before the members of the New York Medical Society, and Dr. A. B. Johnson, of New York City, published an article on this subject in the *New York Medical Record*, September, 1900.

In order to produce a stereoscopic picture, it is necessary to arrange a pair of tubes so that when worked simultaneously they will present on the fluorescent screen a double set of outlines fused into one. To bring out this effect we must alternate the use of the tubes, and so choose the intervals that the continuity of vision may accomplish the fusion of the two images. (Figs. 110, 111.)

The anodes are placed about 6 cm. distant from each other. They are alternately excited by a single coil, but preferably by individual

<sup>1</sup> Electrical Engineering, March 11, 1896.

<sup>2</sup> *Traité Radiologie Médicale*, p. 561.

coils. The terminals of the secondary coil are connected to the tubes alternately, by means of a commutator or switch worked automatically. It is also necessary to have a revolving opaque disk containing two apertures on directly opposite sides, and set apart from each other at a distance corresponding to the space between the examiner's eyes.

If the sector disk and the automatic switch rotate synchronously, and are so adjusted that the tube on the left side becomes luminous simultaneously with the passing of the aperture for the eye of that side,

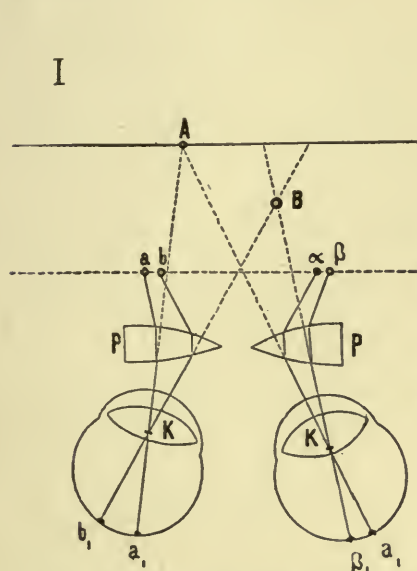

FIG. 110.—Principles of Brewster's refracting stereoscope.

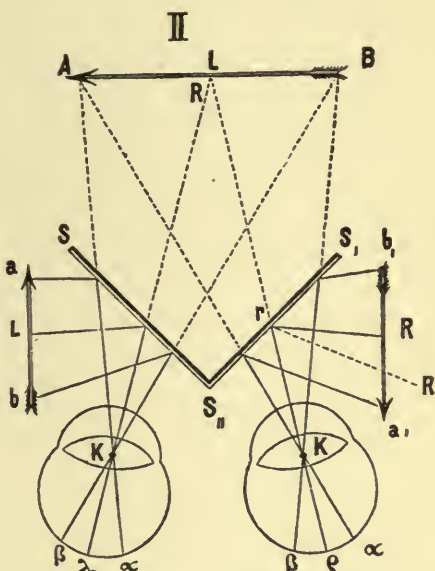

FIG. 111.—Principles of Wheatstone's reflecting stereoscope.

there may be observed a sharp image on the fluorescent screen between the left tube and the perforated disk; this is suddenly followed by an obscuration of the vision of the left eye. In this instance the tube is suddenly thrown into illumination and the image of the part is thrown upon the screen. Dr. Davidson<sup>1</sup> constructed such an apparatus.

## B. STEREO-FLUOROSCOPY.

Briefly, this stereoscopic fluoroscope consists of a fluorescent screen illuminated by two tubes which spark alternately. A rotating disk with appropriately placed slots eclipses each eye alternately and works synchronously with the sparking of the tubes. Each eye sees the shadow

<sup>1</sup>Dr. Mackenzie Davidson described the mechanism of his invention, together with the application of its principles, before the Röntgen Ray Society of London, on December 6, 1900.



cast from one tube. A stereoscopic image is thus seen, the movements of the shutter, etc., being sufficiently rapid to give a continuous illumination of the screen.

E. W. Caldwell<sup>1</sup> uses a large Crookes tube of the double focus variety (two anodes) at a distance of three inches. The fluoroscope is provided with a shutter which permits only one eye at a time to view the fluorescent screen. In other respects the apparatus is very similar to Davidson's device.

### C. TECHNIC OF STEREO-SKIAGRAPHY.

In brief, the technic consists of obtaining two separate skiagraphs of the same part, or of employing two different sensitive plates without changing the position of the parts, but in alternating the position of the Crookes tube two and a half to two and three quarters inches (6 cm.), corresponding to the distance between the pupils. (Fig. 112.) Subsequently these two negatives or skiagrams should be examined with a special instrument. It is important to observe that the part on which the stereoscope is to be used should first be fluoroscoped or skiagraphed in order to locate accurately the seat of the injury.

For use in stereoscopic work, a plate-changing box (Fig. 113), with a top of thin wood or hard fibre and measuring from 14 to 17 inches (35 to 45 cm.), is employed. The size of the plates is marked upon its top, in order to correspond with the dimensions on the drawer of the box. Over this box are placed cross-wires, which facilitate the accuracy of superposition. It is advisable to have a horizontal bar scaled in inches and centimetres. The skiagrapher should first centre the object and then move the tube to the right, corresponding to the vision of the right eye, one and one-quarter inches, or 3 cm., and procure a picture. Place another plate in the drawer of the box without moving the object, and adjust the tube to the left, corresponding to the view of the left eye, and again take a picture. The plates should be marked "right" and "left," to obviate confusion after photographing the part.

Some operators use two Crookes tubes at a distance (the anodes) of seven or eight centimetres, not moving the tube at each exposure. The objection to this method is, that the two tubes will have different degrees of vacuum.

A. B. Johnson, of New York, and P. Czermak prefer to shift the box two and one-half inches instead of sliding the tube.

Another method of taking stereoscopic pictures<sup>2</sup> is to have a plate-holder so constructed that, by a heavy sheet of metal, one-half the contained photographic plate is shielded from the action of the rays. After

<sup>1</sup> Electrical Review, November 16, 1901.

<sup>2</sup> A. B. Johnson, Annals of Surgery, April, 1902.

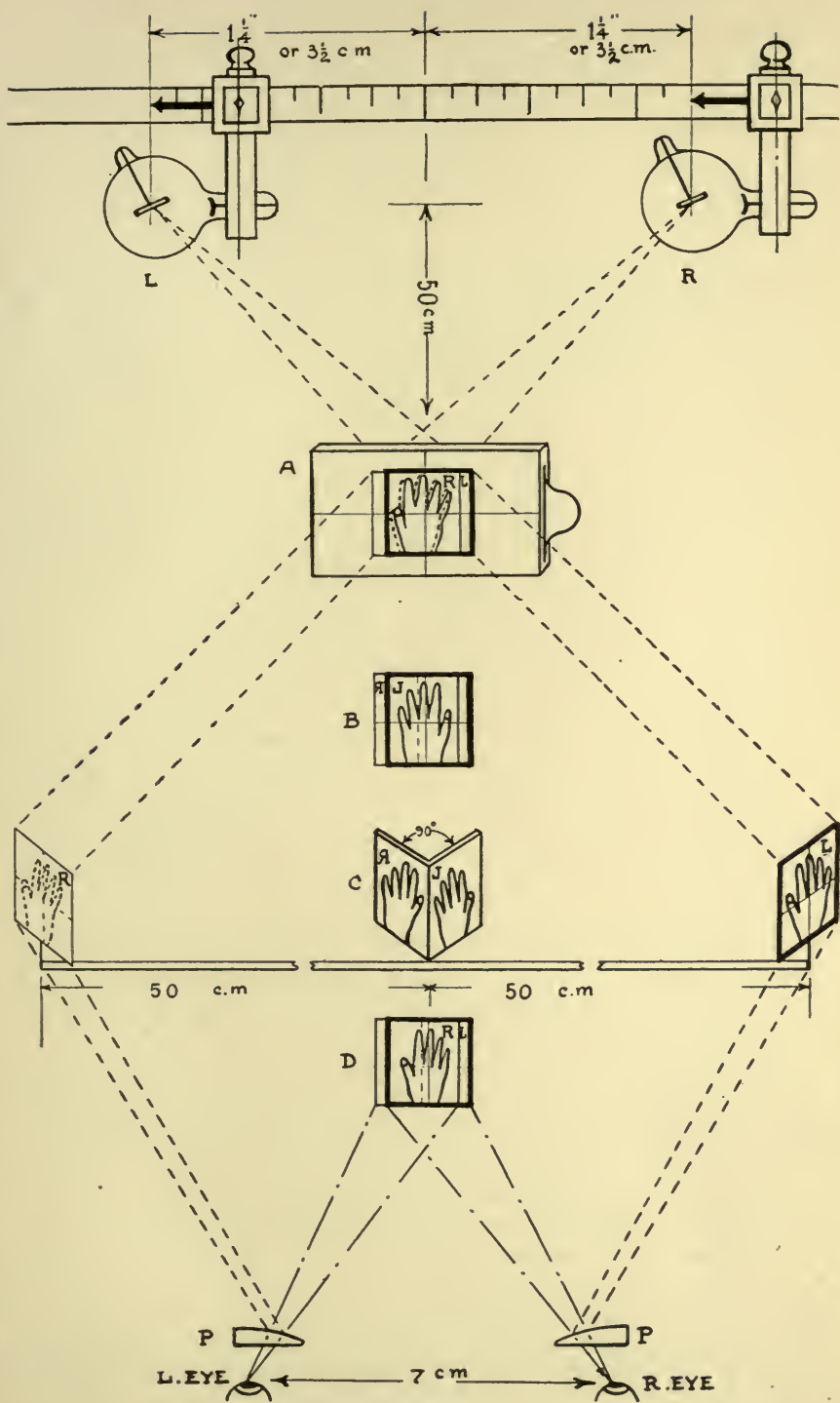

FIG. 112.

exposing one-half the plate, the other half is brought beneath the part, the latter having been previously shielded by a lead screen. The tube is moved a suitable distance, and a second exposure is made. The

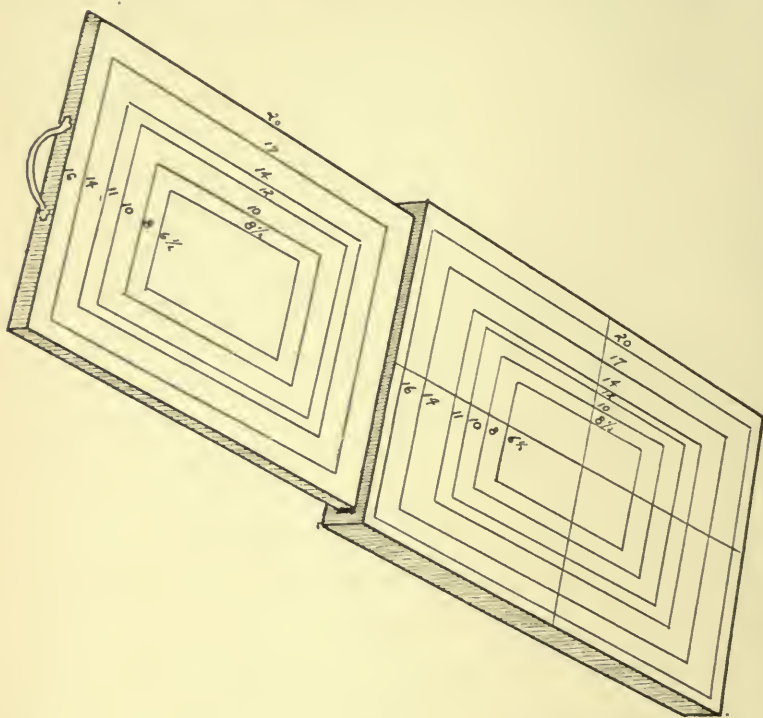

FIG. 113.—Author's plate-changing box.

two pictures thus lie side by side upon the same plate, and may be copied in a reduced size, and viewed as positives on glass or paper in a refracting stereoscope. This method is suited for the extremities, but not for the chest, abdomen, etc.

Marie and Ribaut<sup>1</sup> have derived the following formulæ and table, which they assert will give the most relief and perspective view without fatiguing the operator's eyes. They arrived at these deduced results by a series of experiments founded upon mathematical proofs:

△	Maximum = The maximum displacement of focus tube.
D =	The distance of the tube from the surface of the object.
P =	The thickness of the object.
△	Max. = $\frac{P (D + P)}{50 P}$

<sup>1</sup> Archives d'électricité médicale expérimentales et cliniques, viii., July 15, 1905, and *Traité Radiologie Médicale* by Bouchard, pp. 565 and 566.



When the actual size (dimension) is desired, then  $\Delta$  is equal to 6.6 cm.—viz., the distance between two pupils.

$$6.6 \text{ cm.} = \frac{P \cdot (D + P)}{50 P}$$

*Marie and Ribaut's Table*, showing the varying relationships between the thickness of the part examined and the displacement of the Crookes tube, and also the change in the distance of the tube from the surface of the object. For example, if the part, such as the wrist, is 6 cm. in thickness and the distance of the tube is 40 cm., then the displacement of the tube will be equal to 6.1 cm.

P = THICKNESS OF THE OBJECT.		D = DISTANCE OF THE TUBE FROM THE SURFACE OF THE OBJECT.									
Inch.	Cm.	8 Inch.	20 Cm.	12 Inch.	30 Cm.	15 $\frac{3}{8}$ Inch.	40 Cm.	19 $\frac{3}{8}$ Inch.	50 Cm.	23 $\frac{5}{8}$ Inch.	60 Cm.
$\Delta$ = MAXIMUM DISPLACEMENT OF CROOKES TUBE.											
1 $\frac{1}{4}$	2	1 $\frac{3}{8}$	4.4	3 $\frac{3}{8}$	9.6	6 $\frac{6}{8}$	16.2				
2	4	1 $\frac{5}{8}$	2.4	2 $\frac{1}{4}$	5.4	3 $\frac{1}{2}$	8.8	5 $\frac{5}{8}$	13.5		
2 $\frac{1}{2}$	6	1 $\frac{7}{8}$	1.7	1 $\frac{3}{4}$	3.6	2 $\frac{5}{8}$	6.1	3 $\frac{1}{2}$	9.3		
3 $\frac{1}{8}$	8	1 $\frac{7}{8}$	1.2	1 $\frac{1}{2}$	2.8	1 $\frac{1}{2}$	4.1	2 $\frac{1}{4}$	7.3		
4	10			1 $\frac{5}{8}$	2.4	1 $\frac{9}{8}$	4.0	2 $\frac{6}{8}$	6.0		
6	15			1 $\frac{3}{4}$	1.8	1	2.9	1 $\frac{1}{2}$	4.3	2 $\frac{3}{8}$	6.0
7 $\frac{7}{8}$	20			1 $\frac{6}{8}$	1.5	1 $\frac{5}{8}$	2.4	1 $\frac{6}{8}$	3.5	1 $\frac{7}{8}$	4.8
9	25			1 $\frac{5}{8}$	1.3	1 $\frac{1}{2}$	2.1	1 $\frac{3}{8}$	3.0	1 $\frac{3}{8}$	4.0
11 $\frac{1}{4}$	30			1 $\frac{7}{8}$	1.2	1 $\frac{1}{2}$	1.9	1 $\frac{1}{8}$	2.7	1 $\frac{7}{8}$	3.6

I have devised a special table and an adjustable plate-holder, which I believe possess many advantages.



The table is so constructed that the tube can be made to slide on a rod with great ease, whether on the top, bottom, or side, without discomfort to the patient.

Usually in skiagraphing for either simple or stereoscopic purposes the part is placed over the table or plate-changing box, and the weight of the patient rests upon the plate, thus changing the original position of the foreign body. With the above device, the part may be placed in a natural position, without the plate-changing frame touching it at any point.

To produce two negatives of "equal density" the degree of penetration of the rays should be as nearly uniform as possible, and great care should be exercised in development.

No two tubes have exactly the same degree of vacuum, the same tube changing its vacuum during the exposure. The operator should

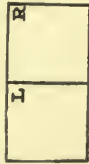
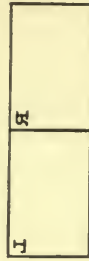
AUTHOR'S TABLE SHOWING THE CHANGES PRODUCED BY REARRANGING THE POSITIONS OF THE NEGATIVES AND TRANSPARENCIES. (FIG. 112.)

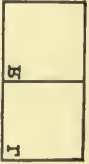
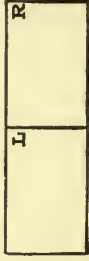
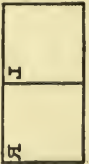
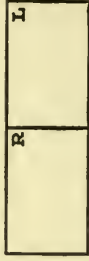
APPEARANCE OF THE LEAD LETTERS ON THE NEGATIVES (WHEATSTONE'S REFLECTING STEREOSCOPE).	POSITIONS OF THE NEGATIVES.	THE ASPECT OF THE HAND.	STEREOSCOPIC EFFECTS.	APPEARANCE OF THE LEAD LETTERS ON THE TRANSPARENCIES (BREWER'S STEREOSCOPE), FIG. 112, D.
	Film side toward the reflecting mirrors; similar to fluoroscopic view or skiagram.	Palmar view of the <i>right</i> hand.	True or binocular effect.	
	Film side toward the reflecting mirrors; similar to fluoroscopic view or skiagram.	Dorsal view of the <i>left</i> hand.	Pseudo-stereoscopic or conversion. (See Fig. 112, B.)	
	Glass side toward the mirrors (skiagrams), eyes corresponding to the Crookes tube.	Dorsal view of the <i>right</i> hand.	True stereoscopic effect.	
	Glass side toward the mirrors (skiagrams).	Palmar view of the <i>left</i> hand.	Pseudo-stereoscopic effect.	

judge the time of exposure of the second plate by experience. A self-regulating tube is preferable. I usually give a little longer time for the second exposure than for the first, as the tube runs down a little and the penetration lessens. Short exposures are most desirable.

Lately I have been developing for the same duration of time two exposed plates in one tray, but I have discarded this method, because the handling of large plates is difficult and the plates differ in density, but now I develop them separately, and by carefully mixing the developer before and during the progress of development, I alter it as the plate requires, to secure equal densities. Soft negatives are preferable.

#### D. METHODS OF VIEWING STEREO-SKIAGRAMS.

*Wheatstone's Reflecting Method.*—This instrument, devised in 1838, consists of two vertical mirrors accurately set at a right angle (the vertex of the angle facing the middle line of the observer's forehead), this arrangement of mirrors slides forward and backward, and is placed over a long board, upon which is a vertical frame parallel with the reflecting plane, forming an angle of  $45^\circ$ . These frames and mirrors are so constructed that the observer can easily superimpose the two pictures. (Fig. 114.)

The pictures must be so placed in the frame as to hold the same position as that occupied by the Crookes tube during exposure. For instance, the picture marked "right" should be placed in the frame to the right of the observer in order to get an anterior view of the part. If placed in the left-hand frame, a posterior view will be obtained. When prints are examined with reflected light, by turning the prints end for end, without changing the "R" or "L" positions, posterior and anterior views may be obtained; this is known as pseudo-stereoscopy.

The advantages of Wheatstone's reflecting method are that: Any sized negative, even before a print is made, can be viewed. When negatives are used without prints, the picture is seen more in detail; negatives can be examined while wet. I bore two holes in a block of wood which is placed between the reflecting mirrors, where the same reflecting light used for negatives can be set for the illumination of prints.

*Brewster's refracting or lenticular stereoscope* is founded on the principle that two pictures can be produced, by causing a displacement of the tube, two and one half inches (6.5 cm.), with the pictures side by side, and viewed with two prisms ( $18^\circ$ ) for each eye. (Fig. 110.)

These pictures will be superimposed according to the laws of refraction. One disadvantage of the Brewster refracting stereoscope is the great degree of the convergence of the axis of vision required, and the necessity of reducing the size of the pictures for use in this refractor. This has been overcome by Walter, of Germany, who places the original size negative in the frame and views it with different prisms. (Fig. 115.)

There is yet another method of viewing these stereoscopic transparencies or prints. The reduced pictures mounted in frames are placed on an endless chain, and are viewed by the operator who looks through the



prisms. The advantages of this method are : That the number of pictures is practically unlimited, unnecessary light is excluded, and that prints as well as transparencies may be employed.

Lately I have made some plastographic views from these stereoscopic negatives. The plastographic method consists in superimposing one print in green over another in crimson, which offers a haziness to the naked eye, but when viewed through eye-glasses (one of a green color and the other of crimson), a very beautiful picture with marked relief

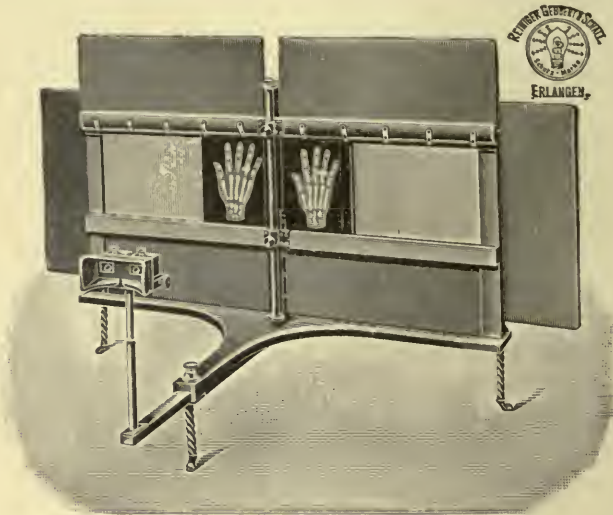

FIG. 115.—Prism stereoscope of Walter.

details is afforded. I believe this process will be useful for stereoscopically illustrating medical journals and scientific books. There is another method of combining stereoscopic pictures without an instrument, which can easily be acquired by crossing the visual axes. Place the skiagraph in front, hold up the index finger in the middle line between the eyes and the skiagrams, and while looking at the top of the finger, a third picture will appear in the centre, offering a most beautiful stereoscopic effect.

#### E. ADVANTAGES OF STEREO-SKIAGRAPHY.

An ordinary skiagraph is composed of superimposed shadows of different densities, which appear flat on the negative or print, and in addition contains many shadows appearing indistinct and weak, but in the stereoscopic pictures the superimposition will be more distinct and visible. Two plates exposed at different angles are used, and any deficiency in one is easily compensated for in the other. Another



FIG. 114.—Wheatstone's reflecting stereoscope, as modified by Weigel.



FIG. 116.—Stereo-skiagram of Colles's fracture, palmar view taken through the splint, and should be viewed with prism stereoscope.





LIBRARY OF THE PHILADELPHIA HOSPITAL

advantage is that the anterior and the posterior views are discernible. In passing, we will very briefly note a few of the many applications of stereo-skiagraphy.

*Anatomy.*—For demonstrating the structure of the bones. In the long and short bones the trabeculae are seen, and in the long bones we may observe the lamellae in the shafts and in the cancellous tissue.

The spiral arrangement of the lamellae is distinctly shown, especially in the humerus and femur, also its change in direction near the articular surfaces.

In examining the skull, the grooves for the meningeal arteries are seen, the concave appearance of the cranial processes, the frontal sinuses, the antrum of Highmore, the turbinated bones, etc.

In studying the mechanism of the joints, these pictures give a perspective of the relations of the articular surfaces of the bones, their actual depths, and the relation of the processes, to the observer.

Arteries, veins, bronchi, and excretory ducts, when injected with opaque materials, such as lead or mercury, show their exact relations (their depths) to the bones, the muscles, etc.

*Surgery.*—Of the numerous methods of locating foreign bodies stereo-skiagraphy is the most satisfactory, because it offers a definite view of the foreign body, and thus enables the surgeon to operate with certainty. The negatives should be soft and full of details, in order to show shadows of different tissues, especially cystic and soft tumor tissue.

When two negatives of this kind are superimposed, the intensity of the shadow is doubled. I am and have been using this method in the Philadelphia Hospital in a series of experiments for detecting and locating brain tumors, etc.

The foregoing statement is also true in regard to fractures. (Fig. 116.) By this method we may procure definite views of the injuries, the exact position of the fragments, the amount of overlapping, the separation, the degree of apposition in deformities, etc. The ordinary skiagraph does not show the variety and character of dislocations. The stereo-skiagraph overcomes this difficulty, and enables one to differentiate between an anterior and a posterior dislocation. We may view the thorax either from an anterior or posterior aspect. The heart and the aorta with their various relations are interesting and fascinating from a practical and scientific standpoint. In the study of normal and morbid conditions, I invariably resort to the employment of stereo-skiagraphy at the Philadelphia Hospital.

LIBRARY  
COLLECTOR  
1914  
5031100  
107 89

## CHAPTER III

### THE CLINICAL APPLICATIONS OF THE RÖNTGEN RAYS.

#### INTRODUCTION.

#### I. The Uses of the X-rays in Anatomy and Physiology.

MUCH has been written about the uses of the X-rays in investigating anatomical structures and in studying the functions of organs. Undoubtedly the knowledge gained by dissection and vivisection through many years of laborious research has been greatly altered and modified through the application of the X-rays.

#### A. BLOOD-VESSELS AND RESPIRATORY TRACT.

I have studied the blood-vessels of infants and adults by injecting into them a substance opaque to the X-rays. The substance used is a concentrated emulsion of bismuth subnitrate, a strong solution of litharge (red oxide of lead), or metallic mercury. In order to demonstrate sharply the arterial tree, the injection must be done carefully and slowly. By some it is deemed advisable first to empty the arterial system of all its blood, and then to inject a solution of zinc chloride, so as to get rid of any existing clots. This solution should be removed by washing, or by forcing water into the arterial system, followed by an injection of metallic mercury, by a force pump connected to the external carotid artery.

The kidney, heart, brain, spleen, liver, stomach, etc., may have their arterial systems demonstrated by first removing them from the cadaver, and then injecting into them some opaque substance, preferably lead oxide. In experiments performed two years ago, I showed the arterial and venous systems of a kidney by employing substances of different densities. Thus metallic mercury was used for the renal artery and its branches, and a weak solution of red oxide of lead for the renal vein and its tributaries.

The brachial, radial, and popliteal arteries have been observed in the living subject, especially in the aged where sclerosis was present.

I have traced the respiratory tract from the larynx to the small bronchioles, by introducing into the upper opening of the larynx a solution of red oxide of lead and allowing it to expand the air-vesicles. The larynx, the trachea with its bifurcation, and the bronchi, with a few of its branches, can be beautifully demonstrated skiagraphically. Instead of the red oxide of lead, I have used small shot, which travel only to the smaller bronchioles, and not into the respiratory passages and air-cells.

## B. BONES AND JOINTS.

So far as the subject of anatomy is concerned, the X-rays have been most useful in studying the osseous system. When the entire fetal skeletal system is mapped out in cartilage, the X-rays cast no shadows of these structures. As soon as ossification of the cartilaginous tissues begins and advances, every step involved in the process may be shown by X-ray skiagrams. The cartilage, being transparent to the rays, casts no shadow.

The rays are of great value in estimating and detecting delayed union of the epiphyses. All X-ray specialists should be thoroughly familiar with the normal appearance of an epiphysis and the time of union. Mr. Poland, F.R.C.S.,<sup>1</sup> London, states, that epiphyseal separation is much more common in males, owing to their rougher forms of amusement, heavier work, etc., and also that the injury is frequently started in intra-uterine life or during awkward, difficult, and instrumental labors. The larger number of injuries are produced during childhood, between the ages of five and ten and even up to the sixteenth year of life.

The most frequent seats of epiphyseal lesions occur in the upper epiphysis of the humerus, lower epiphysis of the femur, lower epiphysis of the radius, and in the phalangeal and metacarpal and metatarsal epiphyses. The times of union of the various epiphyses to the corresponding diaphyses of long bones are as follows:

## UPPER EXTREMITY.

Radius	(upper end)	Between 15 and 17.
Radius	(lower end)	Between 17 and 19.
Ulna	(end of olecranon)	Between 15 and 17.
Ulna	(lower end)	Between 18 and 21.
Humerus	(lower end)	Between 16 and 17.
Humerus	(upper end)	Between 18 and 22.
Humerus	(end of epicondyle)	Between 17 and 18.
Metacarpal		Between 19 and 21.
Phalanges (fingers)		Between 18 and 20.
Clavicle		Between 22 and 26.

## LOWER EXTREMITY.

Tibia	(upper end)	Between 21 and 22.
Tibia	(lower end)	Between 18 and 19.
Fibula	(upper end)	Between 20 and 22.
Fibula	(lower end)	Between 19 and 22.
Femur	(lesser trochanter)	Between 17 and 19.
Femur	(greater trochanter)	Between 18 and 19.
Femur	(head)	Between 18 and 20.

<sup>1</sup>“Traumatic Separation of the Epiphyses.” A monograph published by Smith, Elder & Co., London, 1898.



LOWER EXTREMITY.—*Continued.*

Femur	(lower end)	Between 20 and 24.
Metatarsal		Between 19 and 21.
Phalanges (toes) *		Between 17 and 21.
Innominate	{ Ilium Ischium Pubis (Uniting at 25)	Between 7 and 10.
		Between 7 and 12.
		Between 6 and 15.

As an epiphysis consists of rapidly developing cartilage, it is readily penetrable by the rays, while a skiagram casts a light shadow of the epiphyseal band, which on the negative appears as a dark band. It is essential to diagnose correctly an epiphyseal injury, as it often results in severe deformity. Both sides must be taken for comparison.

The joints and their mechanism have been carefully studied by Dr. Ernest A. Codman,<sup>1</sup> of Boston. He says: "This has been undertaken in two ways,—first, by skiagraphing the normal joints in their extreme positions (extreme flexion, extension, adduction, etc.); secondly, by watching the movements with the fluoroscope. As the parts of the object near the plate show best, it is necessary to take each position from both sides. One thing which will arrest attention is the great distance that apparently intervenes between the bones. This is in part due to the fact that the articular cartilages, being easily traversed by the rays, do not cast a shadow. The wrist-joint has proved most interesting in this study, and the points brought out will be found in the following description. For convenience we may consider the wrist-joint to be made up of four immobile and two mobile elements. (1) Immobile (*i. e.*, those made up of simple bones or of a group of bones, the components of which cannot change relative positions). These are: (*a*) metacarpal of thumb, (*b*) metacarpal of ring-finger, (*c*) metacarpal of index and middle finger, with trapezium, trapezoid, os magnum, and unciform. This last group is so firmly attached to one another that they move as a whole, practically as one bone. No doubt, however, their ligamentous attachments allow of more or less spring in strained positions of the hand brought about by external force.

"2. Mobile (the components of which change relative positions). (*a*) The intermediate row of carpal bones composed of scaphoid, semi-lunar, triquetrum, and pisiform. (*b*) Radius and ulna. From skiagraphs it is found that the carpus and metacarpus are, in any of the extreme positions, in practically the same relation to the radius, no matter what the relation of the radius to the ulna, whether pronation or supination. This is due to the more or less flexible fibro-cartilage, which in any position completes the cups of the radial joint. The question of mechanism, then, is further simplified by leaving out the ulna, which really does not

<sup>1</sup> Archives of the Röntgen Ray, August, 1898.

enter into the construction of the joint except as a pivot. The pisiform also does not enter the mechanism, serving only as a sesamoid for the ulnar tendons.

“Proceeding to eliminate other accessory elements, we can disregard the metacarpal of the thumb, ring and index fingers, each of which moves independently on the large fixed elements composed of the os magnum, etc. The thumb forms a typical saddle joint with the trapezium, with the pommels of the saddle so low that motion is allowed in a small circle, either as rotation within the circumference or straight motions on any of the radii. The metacarpal of the ring finger is allowed a slight antero-posterior motion of a few degrees; that of the little finger the same, but of slightly greater extent, with possibly a degree of adduction. This leaves us with: (a) The large compound fixed element of the os magnum, etc. (b) The radius with fibro-cartilage. (c) The intermediate element of the scaphoid, semilunar, and cuneiform. These constitute the real wrist-joint.

“By injecting a solution of paraffin in alcohol containing substances opaque to the rays, we may bring out the normal anatomical relations of certain of the internal organs. Thus, by injecting this charged solution into the urethra, bladder and ureters, vagina, Fallopian tubes, rectum, and the intestines, we may be able to produce exact skiagrams. To bring out the normal topography of the large intestines, inject with water, and allow it to escape from the small intestines through an incision previously made; this will remove the fecal matter, permitting the opaque solution to fill all crevices or depressions between the rugæ. As has been previously stated, we may by the X-rays determine the movements of the heart in the living. The heaving of the diaphragm, together with the relationship this organ bears to the movements of the pulsating heart, may be illustrated by careful fluorescent screen examinations.”

M. Bouchard<sup>1</sup> reports that he observed a marked dilatation of the left auricle when the intra-thoracic blood pressure was raised during a deep and prolonged inspiration. The same condition exists when the inspirations of a whooping-cough paroxysm are most violent. In two cases examined with the fluorescent screen I was enabled to observe the same condition. During forced inspiration a clear space between the diaphragm and the heart may readily be demonstrated that does not exist during ordinary inspiration.

### C. PHYSIOLOGY OF PHONATION.

The physiology of phonation as seen by careful screen examinations is very interesting. Max Scheier<sup>2</sup> was the first to investigate this subject.

<sup>1</sup> Lancet, September 10, 1898.

<sup>2</sup> Fortschritte a. d. Geb. d. Röntgenstr., B. i., 1897-1898.

In examining the parts involved during phonation, the X-rays should penetrate the head laterally, the screen showing clear shadows of the upper part of the pharynx and the naso-pharyngeal space. If the person under examination utters a vowel sound, the screen shows the velum to be raised, taking a position in the naso-pharyngeal space, the position varying with the sound that is uttered. During the rendition of the vowel letter a, we may observe the velum to rise a little and become more and more elevated as the other vowels (in the order of e, o, u, and i) are successively uttered. In high tones the velum rises more than when low ones are uttered.

If consonants (except resonants and semi-vowels) are pronounced, the velum is raised higher than when the sound i is uttered. If the sounds of the letters m, n, and ng are uttered, the velum rises only a very little and in many cases not at all. The movements and positions of the tongue, lips, and the inferior maxillary bone can also be easily interpreted on the screen. The movements of the larynx, velum, and other associated parts can easily be seen during deglutition, breathing, hawking, and sneezing.

## II. Diagnostic Value in Fractures, Dislocations, and Callus Formation.

The employment of the X-rays in surgery has found a fertile field in the study of fractures, their frequency, character, and varieties. Only of late empirical knowledge has given way to scientific deductions, whilst improved and modified forms of treatment have followed in the wake of this recent achievement.

The deformity associated with a fracture is often deceptive. It may be due to swelling of the neighboring tissues, occurring at the time of or subsequent to the accident. The diagnosis of a fracture is not precluded by employing certain bony landmarks as guides in the diagnosis. Again, shortening does not occur in green-stick fractures, in those which are impacted, or in the intra-articular or in the longitudinal fractures of small bones, such as the carpal or tarsal.

Preternatural mobility is a sign of doubtful value. It often defies recognition in incomplete, intra-articular, and fissured fractures. In fractures near a joint it is often impossible to declare positively if the mobility proceed from the joint or from the supposed seat of fracture. Difficulty may be experienced in grasping the fragments, and rough manipulation exposes the patient to the danger of having a simple fracture converted into a compound one.

Crepitus is likewise an unreliable guide in the diagnosis of fracture. Interposition between the fragments of muscle tissue, fascia, or granulations will mask the true condition. In incomplete, fissured, or impacted fractures of the neck of the femur and humerus, the nature and seat of the



injury may fail to elicit this sign ; again this difficulty may be encountered where muscular action maintains displacement and separation of the fragments, as in transverse fracture of the patella, olecranon, coracoid and acromion processes of the scapula, etc. Lastly, tenosynovitis, movement of a rheumatic joint, and inflammation of a sheath or tendon may closely simulate crepitus.

Movement of a broken bone or pressure at the seat of fracture elicits pain, but its presence is not positively diagnostic. Loss of function is another negative proof, as arthritis and painful joints will often cause this condition.

#### A. THE ADVANTAGES OF THE RÖNTGEN RAY METHOD IN THE DIFFERENTIAL DIAGNOSIS OF COMPLICATED FRACTURES.

The foregoing signs and symptoms are established facts based on clinical knowledge. They, however, do not manifest themselves in any given order, and are not typical, as they do not exist in all cases. They always require an observant eye, a trained ear, and an experienced touch. This method is supplemented by the X-rays, which for accuracy and reliability are far superior to it, and possess the following additional advantages :

1. As a method of diagnosis it is painless. It entails no waiting for the diminution of the swelling nor necessity for the removal of bandages.
2. It allows a positive diagnosis to be made, at the same time revealing the exact nature of the injury.

The variety of fracture, whether oblique, transverse, comminuted or fissured.

Its exact seat and extent, whether of the anatomical or surgical neck or shaft, whether intra- or extra-capsular, simple, complete, or incomplete, green-stick or intra-articular, etc.

The number of fragments, their size, shape, position or location.

The overlapping of the fragments, the exact amount and direction of displacement, and whether the fragments are in apposition or not, can only be ascertained before or after the reduction of the fracture.

3. It allows of its differential diagnosis from the following conditions : dislocation, epiphyseal separation and displacement ; diseases of bones and joints.

The differentiation of a fracture from a dislocation is often difficult, because the great effusion or swelling around the joint will quickly produce marked deformity. Because immediate reduction is necessary, an early diagnosis is an important matter.

When an injury occurs in the vicinity of a joint, especially in children, the epiphyseal condition will at once attract attention. The epiphyseal separation or displacement is most important, but is easily

solved by the skiagraph. In differentiating epiphyseal separation from fracture, the patient's age must be considered, the average date of union varying in each individual.

Fractures of the epiphyses and their displacements can also be differentiated from fractures of other portions of the bone. Fragments of the epiphyses may float in the joint and simulate fracture or dislocation.

## B. DISEASES OF BONES AND JOINTS.

The normal bone appears on the skiagram with its characteristic texture. When any alteration, as increased density, is shown, it is due either to an increased blood supply (as in osteitis or periostitis) or to hypertrophy of the osseous structure, and the beginning of an inflammatory process. Later, when the cessation or absorption takes place, the bone will appear more translucent than normal. This shadow can readily be differentiated from that of a fracture.

*Osteitis and periostitis* are differentiated from fracture and callus with great facility.

*Tumors* of bones can be differentiated from suspected fractures or formations of callus, especially in cases of impacted fractures of the neck of the femur; for the latter, being undiagnosed, and exuberant callus forming, may be mistaken for a tumor.

*Exostoses* of bones, which may occur either after fracture or injury to the epiphyses, can be differentiated from a displaced fragment of fractured bone. Exostoses, however, may be congenital, when not infrequently they are found to be multiple.

The differentiation between coxa vara, fracture of the neck of the femur, coxalgia, and arthritis of the hip-joint, is of great value to the surgeon.

*Diseases of Joints.*—In cases of synovitis, tenosynovitis, arthralgia, rheumatic conditions, bursitis, epiphysitis, and tuberculous arthritis following injuries, the X-rays will prove most valuable in clearing up the diagnosis by differentiating between fractures and diseases or injuries of the soft tissues.

By means of the X-rays we are enabled to show clearly the bones, the muscles, and tendons (such as tendo Achillis, and ligamentum patellæ, tendo-quadriceps, etc.); but often we experience much difficulty in detecting with the aid of the X-rays the injuries to these soft structures in all parts of the human body. In children the X-rays show the capsule and hamstring tendons in the knee-joints, etc.

*Sprains and strains* caused by a twisting of the joint, which result in a rupture of some or all of the ligaments or tendons, are conditions always difficult to diagnose. In those suspected cases when the part is examined

with the X-rays it is noticed that there is no fracture, and by exclusion we are justified in saying that a sprain exists. If the periosteum is torn off by a ligament or tendon, it will be observed under certain favorable conditions. (See Figs. 133 and 145.)

In many instances I have been able to see on the negative the tendons and ligaments in the ankle-joint, and in the lateral view also those of the knee-joint, etc., especially when a soft negative was obtained. In children the negative should be "soft" and full of details; a short exposure with a high-vacuum tube should be the rule.

#### C. VALUE IN THE TREATMENT OF FRACTURES.

The X-ray diagnosis during and after the treatment of fractures is invaluable, assisting the surgeon in approximating the fragments, which can be accomplished by observing the process with a fluoroscope; thus a cast can be applied at once without disturbing the reduced fragments. After the permanent dressing or cast has been applied, another fluoroscopic or skiagraphic examination will reassure him of the correctness of the position of the fragments.

As a fracture is readily diagnosed by the X-rays, it is no longer necessary to delay treatment until the swelling and effusion subside, thus endangering the integrity of the joint.

The frequency of deformities following fractures has been steadily decreasing since the introduction of the X-rays.

In suturing or wiring the great advantage gained from the rays is that the operator is informed whether or not the suturing material is remaining intact.

#### D. CALLUS FORMATION.

In the first stage of callus formation the X-rays reveal nothing. About the twelfth or fifteenth day, it manifests itself as a cloudy mass at the ends of the fragments, and, as calcareous salts are deposited, the X-rays show the presence of a darker substance. The time required to produce this phenomenon depends upon the variety of fracture, the age of the individual suffering from the accident, etc.

*Duration of Callus Formation.*—This is variable, in small bones the time required is brief; thus the metatarsal bones manifest a cloudy appearance about the end of the second week. About the second month the rays show the callus formation to be firm and definite. It is frequently difficult to see the shadow of callus; because the latter is liable to be superimposed by the shadow of the bones. The shape of the callus is fusiform and encircles the ends of the fragments.

*The Varieties of Callus.*—In many cases the bones are united firmly and strongly several months after the accident, nevertheless the X-rays may fail to reveal these conditions. On the contrary, callus may be



thrown out and yet the parts may not be firmly united, as in an oblique fracture of the tibia and fibula. This may arise from the callus being too deficient in quantity to give a shadow on the plate.

*Perfect Apposition.*—If there is good apposition at the ends of the fragments, especially of the long bones, the callus is not easily discovered, being overlapped by the shadow of the bones; but a careful examination will divulge the callus, encircling and forming a faint fusiform shadow, in addition to the compact osseous tissue.

*Slight Overlapping.*—In cases of displacement or slight overlapping, the space between the fragments will be a light area, but as callus is deposited the space will become gradually lighter on the negative, depending upon the thickness of the callus thrown out.

*False Joint.*—If callus does not fill the space between the fragments, the bone at the seat of fracture remains movable and the condition of a false joint is produced. This is the result of a fibrous and not of a bony union. It is of great importance to be able to differentiate true from false union.

*Fractures with Extensive Displacements.*—When the displacement is so extensive (2-3 cm.) that the ends of the fragments do not come in apposition, lateral union occurs, which requires several years for its completion and at best does not result in a very strong coaptation of the fragments.

*Age.*—Because of the vitality of the osseous system and the periosteum, the formation of callus in children and the adolescent is more rapid than in the adult and the aged. This ready deposit of callus must not be mistaken for periostitis the result of the traumatism.

*Structure of Callus.*—When the fracture is old and vicious union has occurred, the X-rays may reveal a partial or complete absence of the bony structure, the texture and trabeculae having suffered a complete change. Care should be exercised not to confound this osseous change with osteo-myelitis or some other bone disease.

### III. Fractures and Dislocations of the Upper Extremity.

#### THE HAND.

*Fluoroscopic Examination.*—The fluoroscopic examination of the hand is satisfactory only when no skiagraph can be taken.

In the examination for fracture, the patient should be seated and all bandages and splints removed. In the presence of a wound, avoid all danger of sepsis by covering it with aseptic gauze. Extend the hand, place it against the screen, 20 inches from the Crookes tube, the rays are to fall perpendicularly. The right hand of the operator grasps the handle of the fluoroscope, with his left he manipulates the hand of the patient, gently pressing and rotating the suspected parts in order to view at all angles the injured part. This pressure in cases of green-stick and

impacted fracture is especially necessary, in order to produce marked separation of the fragments, so as to be able to view the disturbance of texture and the irregular contour of the periosteum.

In order to determine the direction of the displacement in dislocation, the phalanges, carpals, and metacarpals must be examined in the lateral, antero-posterior, and oblique positions. The backward dislocation of the first phalanx of the thumb is of special interest, because there is usually some difficulty in its reduction. (Fig. 117.) Of course the normal hand must first be studied. (Fig. 118.)

*Skiagraphic Examination.*—Secure a sensitive plate of sufficient size to include the entire hand. The arm and elbow should rest upon the table, to obviate any possible movement or tremor. Place a sheet of blotting paper or celluloid between the hand and the plate, to prevent moisture affecting the gelatine coat of the latter. The tube should now be placed 20 inches (50 cm.) above the hand, directly over the middle of the third metacarpal bone. Expose the plate from 3 to 5 seconds. In skiagraphing the phalanges, it is necessary to take both a lateral and an antero-posterior view. Fracture of the scaphoid is shown in Fig. 119.

Lateral and oblique fractures of any of the phalanges may be readily skiagraphed by placing the fingers separately in a lateral position upon the plate. Unfortunately carpal and metacarpal bones cannot be skiagraphed separately. The fluoroscope usually suffices in the examination of the phalanges, but for the carpal and metacarpal bones more satisfactory results are obtained with the skiagraph. If there is much swelling of the palmar surface of the hand, place that member in the dorsal position upon the plate, when the shadow of the bone will appear much clearer.

#### THE WRIST-JOINT.

*Fluoroscopic Examination.*—In examining the wrist-joint, follow the directions given for the hand; manipulate the part gently, so as not to aggravate the injury. This examination should be conducted before splints or casts are applied. Much assistance can be rendered the surgeon if the process of reduction is watched through a fluoroscope.

*Skiagraphic Examination.*—The wrist-joint should be skiagraphed in the supine, prone, and the lateral positions both before and after reduction and also before removing the cast. Place both the hands upon the plate for comparison. A small weight is placed upon the hand, or the arm is strapped to a board, to prevent tremors. In the lateral position the tremor can be avoided by the patient grasping a book or other small object.

*Lower End of the Radius and Ulna.*—An epiphyseal separation at the lower end of the radius may be mistaken for a Colles's fracture. (Fig. 124.)

It must be borne in mind that the epiphysis commences to ossify about the end of the second year of life, and unites with the shaft at about the nineteenth or twentieth. Vertical fracture of the epiphysis is rare.

The difficulty in detecting this fracture is due to a wrong position of the tube, in consequence of which its rays not falling perpendicularly do not traverse between the fragments; or the shadows of the fragments may superimpose, and thus obliterate the dark line on the negative.

Though dislocations at the wrist-joint were regarded by the older writers as of infrequent occurrence, the advancements made in diagnosis and the discovery of the X-rays prove them to be of much greater frequency than was formerly supposed. These dislocations may be backward, forward, or lateral, and may occur independently of fracture of the radius or ulna.

#### THE FOREARM.

A fluoroscopic examination of the forearm is conducted in the same manner as for the wrist-joint.

A skiagraphic examination can be taken while the arm is in either the supine, prone, or lateral position. The plate should be 8 x 10 inches (20 x 25 cm.), the time of exposure from 5 to 10 seconds.

Fractures of the middle third of the radius and ulna in children are discerned with difficulty by the fluoroscope, being usually the so-called green-stick fractures. A skiagraph is preferable. (Fig. 125.)

In fractures of the radius and ulna, if the two lines of injury are near each other, the subsequent callus formation may bring these bones together, thus producing a synostosis, which will interfere with rotation of the arm. The X-rays will indicate the amount of callus thrown out.

In Colles's fracture a skiagraph taken in the antero-posterior position may not show the fracture, or should the fracture appear the degree of displacement of the lower fragment may not show at all. This will necessitate a skiagraph taken in the lateral positions;—*i. e.*, the ulnar or radial sides being in contact with the plate. (Figs. 120, 121.)

In the oblique type of Colles's fracture the line of dissolution often includes a chipping off of the styloid process of the radius.

Fracture of the styloid process of the radius may be found independent of (Figs. 122, 123), or in connection with, Colles's fracture. Often the anterior border of the radius is fractured, producing subluxation of the wrist.

Multiple fracture, especially that form known as the Y-fracture, is more common than is usually supposed.

The supine or prone position of the wrist may show in the skiagram either lateral displacement, transverse, oblique, or Y-fracture, and fissure or fracture of the styloid process of the radius.





FIG. 117.—Inward dislocation of the first phalanx of the thumb. (Case of Dr. G. E. Shoemaker.)



FIG. 118.—The normal hand, taken with high-vacuum tube.



FIG. 119.—Fracture of the scaphoid, 1, 1.



FIG. 120.

COLLES' FRACTURE.

FIG. 121.

(Antero-posterior view.)

(Lateral view.)

Left picture, taken in the prone position, shows, at F → and F, a transverse fracture of the radius and a green-stick fracture of the ulna. E → and E → are the ununited epiphyses. The right-hand picture is the same, taken in a lateral position. (Case of Dr. Franklin Brady.)





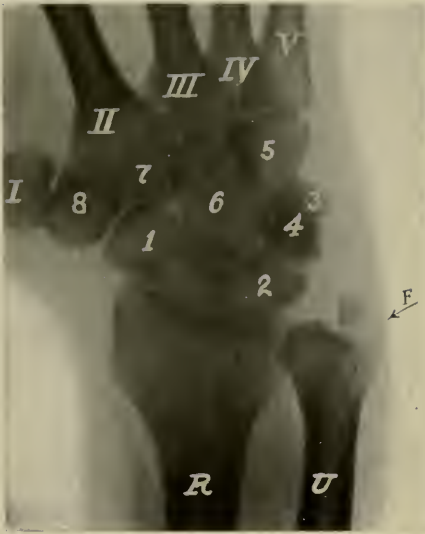

FIG. 122.—Fracture of styloid process of the ulna (supine position, hand slightly abducted).



FIG. 123.—The same, in the prone position, which does not show the fracture (arrow 5).



FIG. 14.—TYPICAL COLLES'S FRACTURE.—The bones appear white, as seen on the negative: 1, scaphoid; 2, semilunar; 3, cuneiform; 4, pisiform; 5, unciform; 6, os magnum; 7, trapezoid; 8, trapezium.





Occasionally the styloid process carries with it when fractured a part of the dorsal border of the radius ; this is known as Barton's fracture. Colles's fracture is frequently associated with fractures of the styloid process of the ulna accompanied by rupture of the triangular fibro-cartilage.

#### THE ELBOW-JOINT.

*Fluoroscopic Examination.*—It is very unsatisfactory to examine the elbow in the antero-posterior position with the ordinary fluoroscope, as the curvature of the part prevents a close approximation of the screen. To meet this difficulty it is necessary to employ a small tubular fluoroscope which fits snugly the anterior surface of the joint. A disadvantage of this fluoroscope is the small area brought into view. To obviate this the author has devised a flexible fluoroscope which, when properly used, will bring all the parts into view.

The lateral position is by far the most convenient one in which to examine injuries of the elbow-joint with the fluoroscope. The joint should be viewed from the internal, external, and lateral positions.

*Skiagraphic Examination of the Elbow.*—Skiagraph the elbow either in the anterior, posterior, or antero-posterior position. The forearm should be well extended and placed in the supine position. The sensitive plate  $8 \times 10$  inches, (20 x 25 cm.) is placed under the olecranon process of the ulna, with the tube held at a distance of from 12 to 16 inches (30 to 40 cm.) above the joint.

The elbow-joint is best shown in two views, the antero-posterior and the lateral.

To skiagraph the elbow in the postero-anterior position, place the patient in the ventral recumbent posture, with the arm extended by his side. Place a small plate under the joint, remembering that it should be as near the bones as possible.

A sensitive film can be placed in the flexure of the elbow-joint and the tube beneath the table ; a convex block of wood, also conforming to the contour of the flexure of the joint, will hold the film in position.

In the lateral position the plate should be placed either under the internal surface of the elbow with the tube above the joint, or over the external surface with the tube beneath the table, the former being preferable. In both of the above methods, the elbow should be flexed and brought on a level with the shoulder of that side.

To properly interpret the shadows, a normal corresponding joint in the same individual must first be carefully studied; especially is this the case with children. In the antero-posterior position, we notice the shadow of the olecranon process clearly visible and superimposed upon the shadow of the sigmoid fossa. Light shadows are seen between the articulating surfaces of the humerus and ulna.

A skiagram of the elbow in the antero-posterior position always shows a light horizontal shadow between the internal condyle of the humerus and the coronoid process of the ulna, which has often deceived the inexperienced into diagnosing a fracture of the olecranon. Fig. 126 shows the lighter portion extending inward between 10 and 7, toward 11. This shadow is in reality that of the olecranon process of the ulna, and is deceptive, because it is bounded by heavier shadows, which are cast by the humerus and olecranon on one side, and by the coronoid and the olecranon processes on the other.

Fractures of the head or neck of the radius are of rare occurrence. (Fig. 126.)

Separation of the epiphyses is extremely rare. (Fig. 127.) It is convenient to know that ossification begins about the sixth year, and union with the diaphysis occurs about the sixteenth or seventeenth year.

Fractures of the upper third of ulna, with dislocation of the head of the radius, are skiagraphed by lateral exposure. (Fig. 128.)

In longitudinal fracture of the upper end of the ulna, the lateral position will not reveal the fracture, but it must be skiagraphed in the antero-posterior position.

In order to separate the fragments, when the fracture is in close proximity to the insertion of the brachialis anticus, the arm should be well extended during the examination.

*Dislocation of the Elbow-Joint.*—For dislocations of the elbow-joint a lateral view should be taken with fluoroscopic and skiagraphic examinations. In children, this dislocation may simulate epiphyseal separation. Supra-condyloid fracture, partial fracture of the internal epicondyle, and partial detachment of the external condyle of the humerus, are well shown in Figs. 129, 130, 131, and 132. Detachment of the supinator longus muscle, simulating a fracture of the humerus and epiphysitis of the humeral head, at first thought to be a fracture, are depicted in Figs. 133, 134, and 135.

#### THE MIDDLE THIRD OF THE HUMERUS.

Fluoroscopic and skiagraphic examinations readily reveal, from all sides, fractures of the middle third of the humerus.

#### THE SHOULDER-JOINT AND ITS VICINITY.

On account of the immediate swelling of the part, examination is often rendered very difficult.

*Fluoroscopic Examination.*—If the patient is a child or a thin person, this method of examination will be satisfactory.

Should one suspect fracture with dislocation, it is preferable to take a skiagram, as it requires less disturbance of the parts. The examination is made in the antero-posterior position.

Fractures of the surgical neck of the humerus are quite common (Fig. 136), while fractures of the anatomical neck are very rare.

In skiagraphing the shoulder-joint, in order to avoid erroneous interpretations, the operator should always bear in mind that the epiphysis and diaphysis do not unite until the twentieth year.

*Skiagraphic Examination.*—The patient is placed in the dorsal recumbent posture, the head being supported by a low pillow, and the unbandaged arm is extended to an angle of  $35^{\circ}$ , and is immobilized by employing a sand-bag or small weight.

In corpulent individuals the head of the humerus may be too distant from the sensitive plate. This may be remedied by simply tilting the patient to that side, or by raising the uninjured shoulder on a pillow. The rays should be directed over the lower border of the glenoid cavity.

In viewing from the anterior position, the patient may lie either on his abdomen or on his back. When the patient assumes the former position, the tube is placed over the spinous process of the scapula, and the plate rests on the table, under the joint. In the dorsal recumbent position the tube is placed under the table, and the patient may rest either in the dorsal decubitus or semi-recumbent position. I put the plate in an adjustable plate-holder, which prevents it from coming in contact with the patient. The rays should be applied only during the period in which the patient holds his breath, after a full inspiration or expiration. These intermittent exposures should be repeated 4 or 5 times. This method prevents the blurred effects which one sees occasionally.

*Dislocations or Subluxations of the Shoulder.*—In these classes of cases there is likelihood of wrong interpretation of the skiagraphed part, as different positions of the tube and arm will give varying relations of the humeral head to the glenoid cavity. In order to guard against this error, a large plate should be used on both shoulders, and the parts skiagraphed simultaneously, by placing the tube on the median line, and maintaining both shoulders and arms in precisely the same position. Instead of using one large plate, we may employ two plates placed together.

The acromio-clavicular space, being cartilaginous, appears as though a fracture or separation existed. Sometimes this light area is exaggerated on account of the faulty or oblique position of the shoulder or part.

The oblique ridge separating the head from the anatomical neck often shows a white line on the negative. A depression where the spinatus muscle is attached may also be seen on the plate. Fig. 137 shows a fracture of the acromion process.

#### THE CLAVICLE.

Fractures of the clavicle occur mostly in children, yet they may happen at any age. (Fig. 138.) Skiagraphic examinations are best obtained by taking either anterior or posterior views. Dislocation of the scapular end and other varieties can be readily discerned.



### THE SCAPULA.

Fracture of the scapula is best skiagraphed in the dorsal recumbent posture. The coracoid process is best skiagraphed with the patient on his abdomen; the better method is to place the tube in such a position that the rays will pass through the axillary space, the plate being fastened over the clavicle, the coracoid, and acromial processes.

Always endeavor to throw the shadow of the process under the clear space of the clavicle, and not over the neck of scapula.

### FRACTURES OF THE SKULL.

Many difficulties are met in skiagraphing fractures of the skull, owing to the superimposition of the shadows of the bony walls surrounding the part under examination, and the difficulty in bringing the plate in proper apposition to the curved outline of the skull cap. Fluoroscopic examinations are satisfactory in the thin skulls of young children. Skiagraphs can be taken in the lateral, the fronto-occipital, and the occipito-frontal positions, but the lateral view affords greater detail of structure and offers a clearer field.

Fissured fracture of the base defies detection, because the line of fracture is inaccessible in any position in which the tube may be placed. Any change in the contour of the inner or outer tables of the skull or the presence of the formation of callus, can be brought out by placing the tube and plate in exactly the right position, which can be determined only by constant practice.

## IV. Fractures and Dislocations of the Lower Extremity.

### THE FOOT.

*Fractures.*—Fractures of the phalanges of the foot are of the comminuted or splintered type.

Fractures of the metatarsal bones, which were formerly thought to be extremely rare, have been shown by the X-rays to be of common occurrence. (Figs. 139 and 140.) The so-called "swelling" of the feet is often due to fracture of one or more metatarsal bones. The first and fifth of these bones are most frequently broken, the resulting fracture being of the compound type.

Fractures of the astragalus and os calcis are not infrequent, the force travelling through the body or neck. This injury is often associated with a separation or a dislocation of one or the other fragment. Fracture of the os calcis may involve the body of the bone or one of its processes, and is frequently comminuted. Fractures of the astragalus and os calcis can readily be seen on the screen if there is sufficient separation of the fragments. The lateral view is always preferable.

Fractures of the phalanges and metatarsal bones may be disclosed by a fluoroscopic examination. Skiagrams of these fractures may be made



FIG. 125.—Green-stick fracture of the ulna, *B*, with a transverse fracture of the radius, *D*. *A* and *C* are the epiphyses.



FIG. 126.—Fracture of the neck of the radius, *8*.

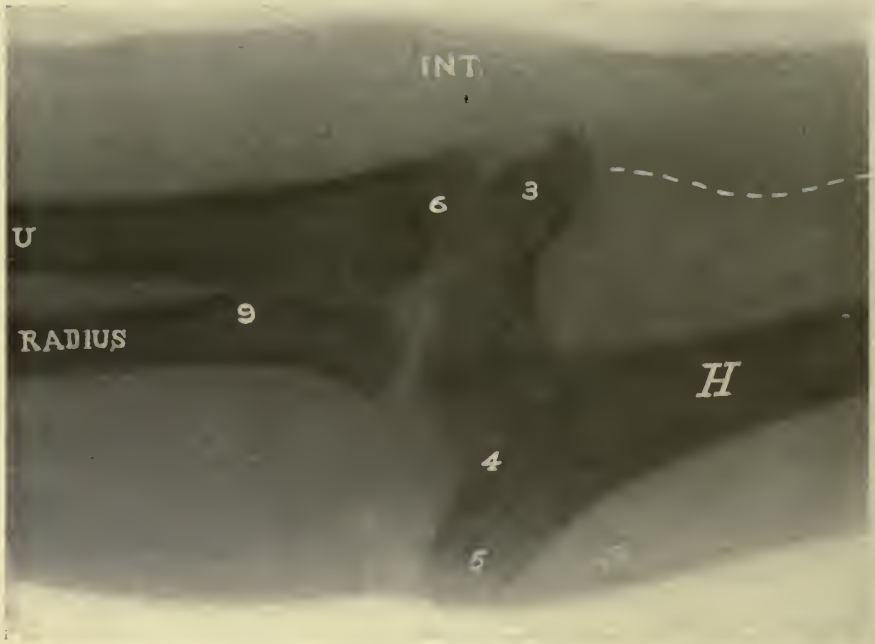

FIG. 127.—EPIPHYSEAL SEPARATION AND DISPLACEMENT OF THE LOWER END OF THE HUMERUS.—The condyles 3, 4, remain at their normal positions, the diaphysis having suffered a lateral displacement. The dotted line indicates the normal position that the diaphysis should occupy.

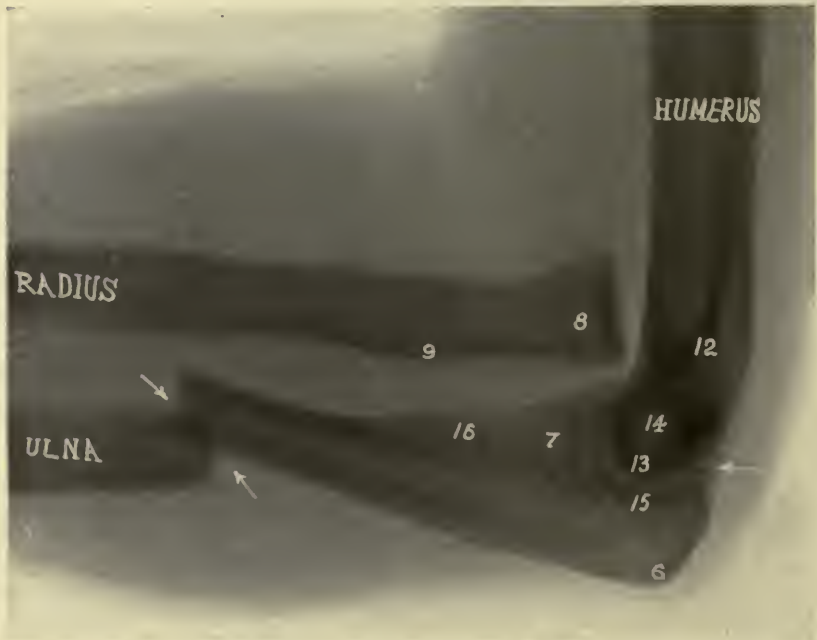

FIG. 128.—Fracture of the ulna and displacement of the head of the radius, 8.





FIG. 129.—Supracondylar fracture of the humerus.



FIG. 130.—Fracture of part of the internal epicondyle after forcible reduction for dislocation.

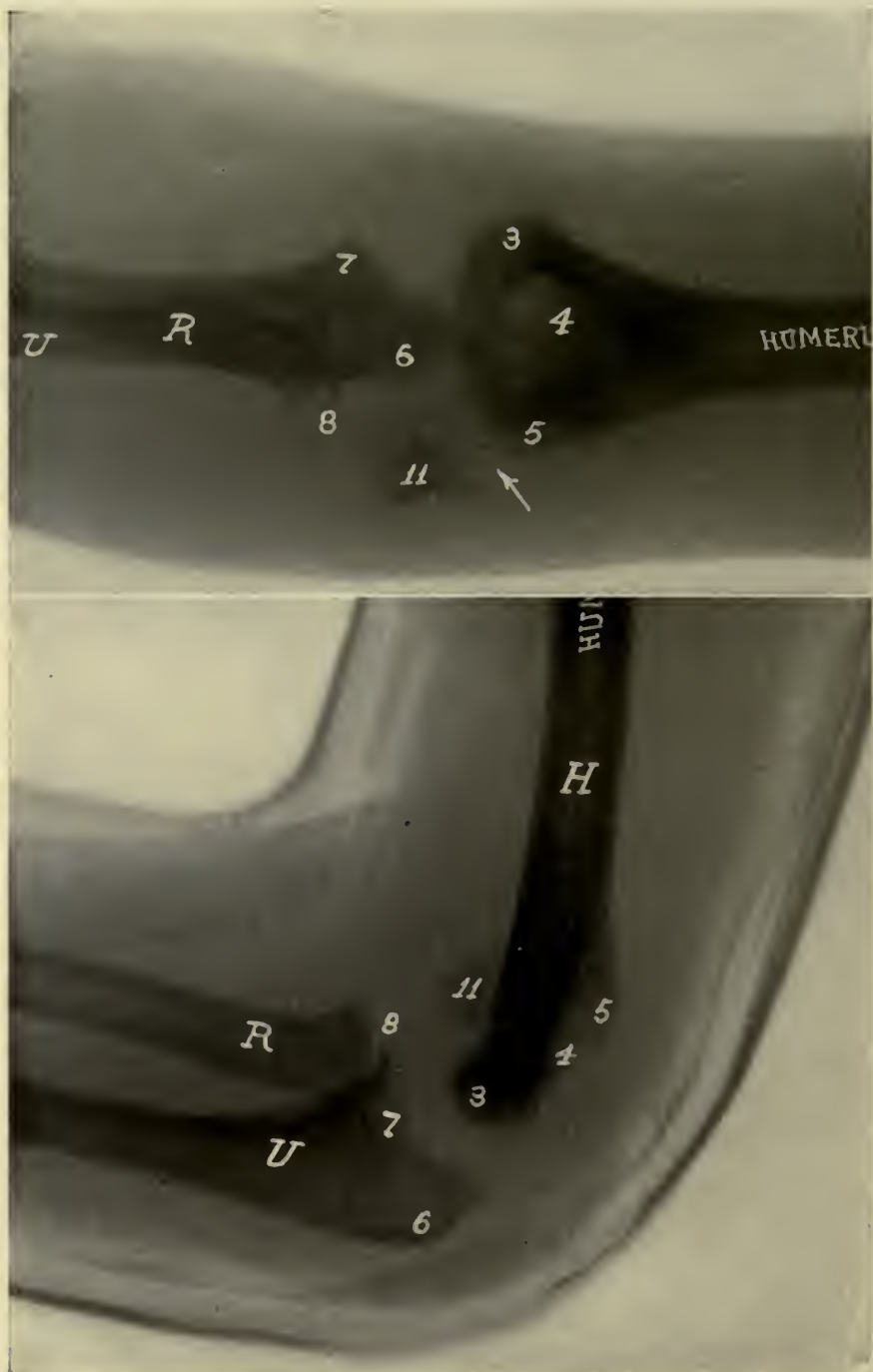

FIG. 131.—Detachment of a portion of the external condyle of the humerus, antero-posterior view.

FIG. 132.—The same, lateral view. 3, inner condyle; 4, olecranon fossa; 5, external condyle; 6, olecranon process; 7, coronoid process of the ulna; 8, centre of ossification of the head of the radius. (Case of Dr. Franklin Brady.)



FIG. 133.—DETACHMENT OF THE SUPINATOR LONGUS MUSCLE, INDICATED BY THE ARROW.—The injury was thought to be a fracture prior to X-ray examination. (Case of Dr. H. C. Kellner.)



FIG. 134.—EPIPHYSITIS OF THE HUMERAL HEAD.

FIG. 135.—THE CORRESPONDING NORMAL SIDE.

Epiphysitis of the head of the humerus, diagnosed as a fracture. 3, internal epicondyle; 4, olecranon fossa; 5, external epicondyle; 6, olecranon process; 7, coronoid process of the ulna; 8, head of the radius; 9, tuberosity of the radius; 10-11, trochlea; 11, centre of ossification of the capitellum.





FIG. 136.—Subluxation of the shoulder-joint, L →; F → is a fracture of the surgical neck.

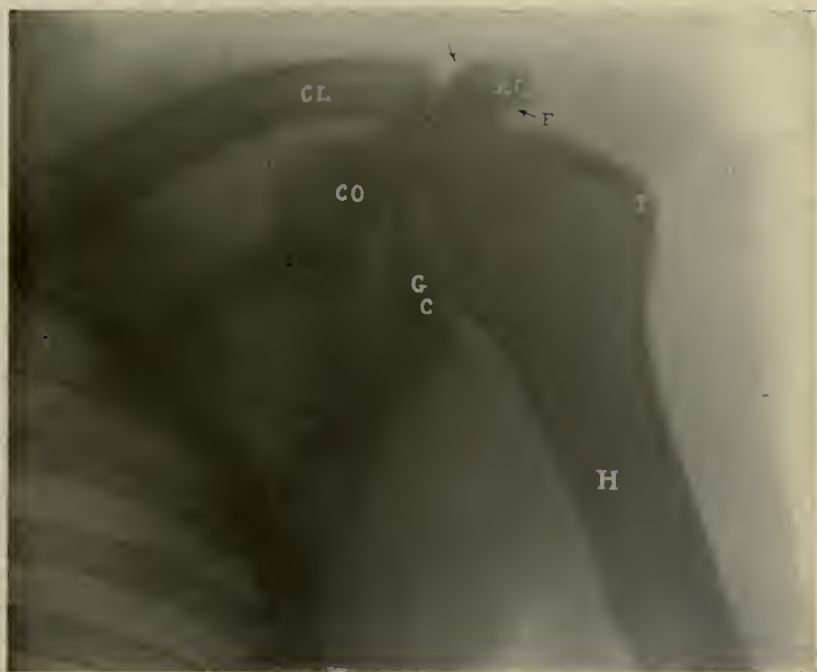

FIG. 137.—Fracture of the acromion process, —→ F. (Case of Dr. C. H. Burr.)

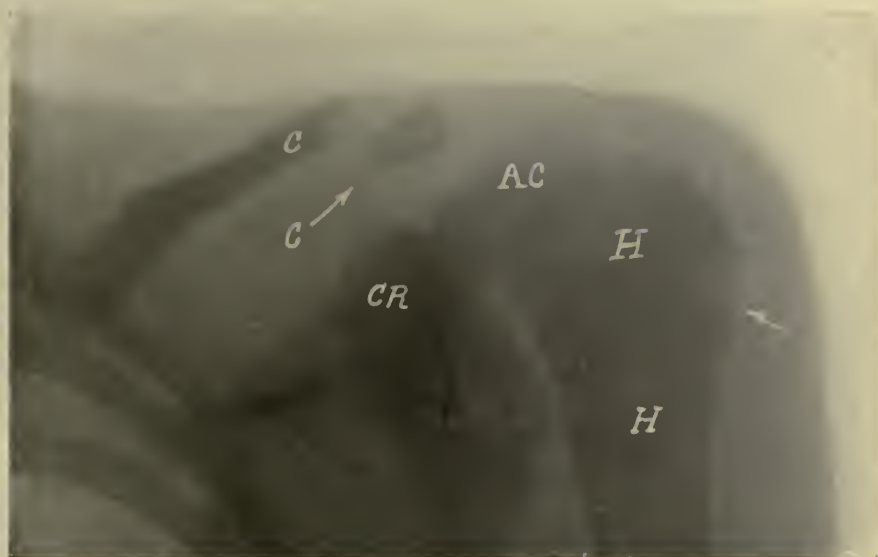

FIG. 138.—Fracture of the acromial end of the clavicle. (Case of Dr. W. L. Rodman.)



FIG. 139.—Fractures of the 1st, 2d, 3d, and 4th metatarsal bones and of the 1st phalanx of the great toe.



in a number of positions. In the anterior-posterior position the patient occupies a high stool with a back rest, which affords greater comfort and lessens the possibility of movement. The foot should be placed on a small supporting bench which may serve as a holder for the sensitive plate as well.

The foot is extended by gradually moving the bench from the stool, the patient in the meantime being instructed to keep the sole of the foot evenly upon its top. In skiagraphing a "partial" lateral view the rays from the tube should fall more or less obliquely, thus preventing a superimposition of the metatarsal shadows.

Skiagraphy of the tarsal bones is more difficult. The astragalus may be successfully skiagraphed in an antero-posterior view, by placing the tube anteriorly at the upper angle of the foot and the sensitive plate posteriorly, plantar or dorsal. Put both feet close together upon two separate 8 x 10 inch (20 x 25 cm.) plates, with the tube in the centre. The tarsal articulation can be best skiagraphed by placing the plate against the dorsum of the foot and allowing the rays to penetrate through the plantar surface.

*Dislocations.*—Phalangeal dislocations of the foot closely correspond to those of the hand, but are of much less frequent occurrence.

Dislocation of the metatarsal bones at the tarso-metatarsal articulation, usually occurs as a complete displacement involving several or all of the metatarsal bones on the dorsum of the foot. Plantar dislocations are very rare.

The technic in dislocations is practically the same as has been discussed under fractures.

#### THE ANKLE-JOINT AND CONTIGUOUS STRUCTURES.

*Fractures.*—Fractures of the ankle-joint involve the tibia, fibula, and tarsal bones, either alone or in combination. For all practical purposes they should be divided into two groups, dislocation-fracture and sprain-fracture.

A supramalleolar fracture of the tibia and fibula is best skiagraphed antero-posteriorly. Skiagrams of typical Pott's fracture show a transverse or oblique line of injury in the lower third of the fibula, with fracture of the malleolar processes of the tibia. (Fig. 141.) A skiagram is best made by placing the patient in a recumbent or semi-recumbent position. The sensitive plate, 8 x 10 inches (20 x 25 cm.), should be placed directly under the seat of the injury, as low as the os calcis, the leg being slightly rotated inward to prevent superimposition of the shadows of the tibia and fibula. The tube should be about 20 inches (50 cm.) distant from the plate. The time of exposure varies between 10 and 20 seconds. When the fracture is longitudinal, without displacement, the antero-posterior view may fail to reveal the presence of fracture; in such a case, it

is imperative that a lateral view should be taken, with the suspected side next to the plate. A fracture box should be employed to secure immobilization.

Epiphyseal separation and malleolar and supramalleolar fractures must not be confounded with Pott's fracture.

*Dislocations of the ankle* present nothing characteristic and therefore require no special technic. They should be examined in both positions.

#### THE LEG (MIDDLE THIRD). (Figs. 142, 143.)

*Fractures.*—When making antero-posterior and lateral skiagrams in this region, prevent the shadow of the tibia superimposing upon that of the fibula, or *vice versa*.

#### THE KNEE-JOINT.

*Fractures.*—Complete transverse fracture of the tibia in its upper third, fracture of the tuberosity, and traumatic epiphyseal separation of the upper end of the tibia, are readily discerned by the X-rays.

The knee-joint should be examined from two views, either the antero-posterior or the lateral. A fluoroscopic examination of the knee-joint is rather unsatisfactory except in ankylosis. Gliding movements of the various ligaments and patella may be studied, and severed ligaments can often be detected. In osseous ankylosis the articular plane of the knee is obliterated, while in the fibrous form there is usually no such obliteration.

In making antero-posterior skiagrams, have the patient on his back, with the head and chest elevated, the extremity of the foot fixed resting upon an extension of the operating table, or tied to fracture box. A sensitive plate 8 x 10 inches (20 x 25 cm.) is placed against the posterior aspect of the knee-joint, with the tube directly over the patella. The shadow of the patella is usually very faintly superimposed upon that produced by the lower end of the femur. The patellar shadow is increased in density if the plate is placed in front of the patella and close to it, the rays being allowed to penetrate from behind. In making lateral skiagrams the patient should lie upon the injured side with the fractured joint slightly flexed, the other leg should be extended or fully flexed so as not to interfere with passage of the rays. Detachment of the tubercle of the tibia is shown in Fig. 145.

*Fractures of the Patella* (Fig. 144).—In transverse fracture of the patella, the lateral fluoroscopic view shows the separation of the fragments. Stellate and fissured fractures can only be shown by a skiagraph taken in the postero-anterior position. The patient should lie face down, with the tube behind the joint and the plate under the patella. The sesamoid bones give distinct shadows and floating or loose bodies are often detected. Detached cartilages are very difficult (and often impossible) to skiagraph.

## THE FEMUR (MIDDLE AND LOWER THIRDS).

*Fractures.*—Fractures of the shaft of the femur are common. In children the injury is usually transverse with little or no displacement, while in adults it is usually oblique with much displacement. In making skiagrams of the shaft, two plates, in exactly opposite directions, should be taken. Fractures of the lower third of the femur are easily diagnosed by the X-rays.

## THE HIP-JOINT.

*Fractures.*—Fractures of the upper end of the femur are divided as follows: (1) intra-capsular, (2) epiphyseal separation, (3) extra-capsular, (4) fracture of the trochanters, (5) isolated fracture of the trochanter major, and (6) fracture of the upper portion of the shaft immediately below the trochanters.

Fluoroscopic examination of the hip-joint in children is usually satisfactory, but the thickness of the tissues makes it unsuited for adults. At best, skiagraphy of the adult hip-joint is troublesome, especially if the subject is very corpulent and the part painful.

The technic is as follows: Have the patient fully extend the leg of the injured side. If this is impossible, place a pillow under the partially flexed knee. Place two superimposed plates, 10 x 12 inches (25 x 30 cm.) or 11 x 14 inches (28 x 35 cm.), under the hip, which should extend from the iliac crest and project two inches from the outer aspect of the leg. The tube should be placed directly over the head of the femur, and from 20 to 25 inches (50–63 cm.) from the plate. If the foot is inverted or everted from the injury, do not correct it. Guard against tremors by the use of a pillow, sand-bags, bandages, or suspended weights.

It is often valuable to take both hip-joints at the same time for comparison. For this employ either a large plate that will include the shadows of both hips or two smaller plates touching side by side. Adjust the tube to the median line at a distance of more than 20 or 25 inches (50–63 cm.), the anode pointing to the pubic symphysis, remembering that this position will require a longer exposure. It must never be forgotten that certain positions of the foot will cause the neck of the femur to assume varying angles, shapes, and lengths to the acetabular cavity, and that the shape, distance, and position of the lesser trochanter will change its relation to the descending ramus of the pubis. To convince others of the correct interpretation of the negative, employ as a confirmatory measure a simultaneous skiagraph of both hip-joints, previously securely binding the feet and ankles in the vertical position, thus placing the necks of the femora in identical positions, or take another without tying the feet, and let the feet occupy their actual positions in order to show the difference. As very fine detail work—*i. e.*, the structural texture of



the femur—must especially be brought out, it is apparent that, if this sharpness of definition is lacking, an impacted or fissured fracture might easily escape detection.

In doubtful and obscure cases, advantage is gained by making another skiagram in the ventral position; because of the thickness of this region, the time of exposure is lessened by using the intensifying screen, which sacrifices, however, the fine details. I therefore do not recommend it.

Antero-posterior fractures of the acetabulum can readily be skia-graphed, but stellate fracture is extremely difficult to determine. Skiagrams of impacted fractures of the neck of the femur do not present the usual light lines. The fracture can, however, be diagnosed by the shortening, and the slight irregularity in the size, shape, and angle of the neck of the femur.

The osseous ridge running between (intertrochanteric ridge) the trochanters posteriorly, usually gives a light line on the negative, which must not be mistaken for fracture. In the fracture at the base of the neck, the angle diminishes from the normal to  $90^{\circ}$  or less. An incomplete, intertrochanteric fracture is well shown in Fig. 146.

Chemical intensification of a negative defines the osseous tissue more clearly, but as the detail of the soft structure is thereby diminished, a second exposure is preferable, if possible.

A satisfactory negative should clearly differentiate the head and neck of the femur and the hip bones. If not sufficiently dense, the lines and shadows indicative of fracture will not be visible. The tendency in making these negatives is to over expose, but better results are obtained by using a tube of high penetrability, with an electrolytic interrupter.

*Dislocations.*—Congenital dislocation of the hip in children (Figs. 147 and 148) can be well demonstrated by skiagrams, showing the presence or absence of the ring of the acetabular cavity, the depth of the acetabulum, the position, shape, and situation of the head of the femur. I have made studies of a series of cases, before reduction, after reduction through the cast, and after removal of the cast, in the service of Professor Adolf Lorenz during his recent visit to this country, and they proved to be very suitable and interesting from a stereo-skiagraphic stand-point.

Pathological dislocations (Figs. 149 and 150) the result of tuberculosis, osteo-arthritis, Charcot's disease, etc., are easily skia-graphed in the manner outlined under fractures. In pathological dislocations the head and neck of the bone are absent, as in cases of epiphysitis.

#### THE OS INNOMINATA, SACRUM, AND COCCYX.

*Fractures.*—The clinical diagnosis of fracture of the pelvis can only be made when the separation of the bones is marked or when displacement is considerable. When only slight separation exists, the X-rays



FIG. 140.—FRACTURE OF THE MIDDLE OF THE FOURTH METATARSAL BONE.—I, II, III are the metatarsal bones; A, 1st internal cuneiform; B, 2d middle cuneiform; C, 3d external cuneiform; D, cuboid bone; E, scaphoid; F, astragalus; G, anterior process of the os calcis; 1, 2, sesamoid bones.



FIG. 141.—POTT'S FRACTURE.—F→, F→, fractures of both malleoli: D→ shows the inward dislocation of the tibia. The internal malleolus, at 2, should be in the dotted area, having become detached and left in the position marked 2 (white).

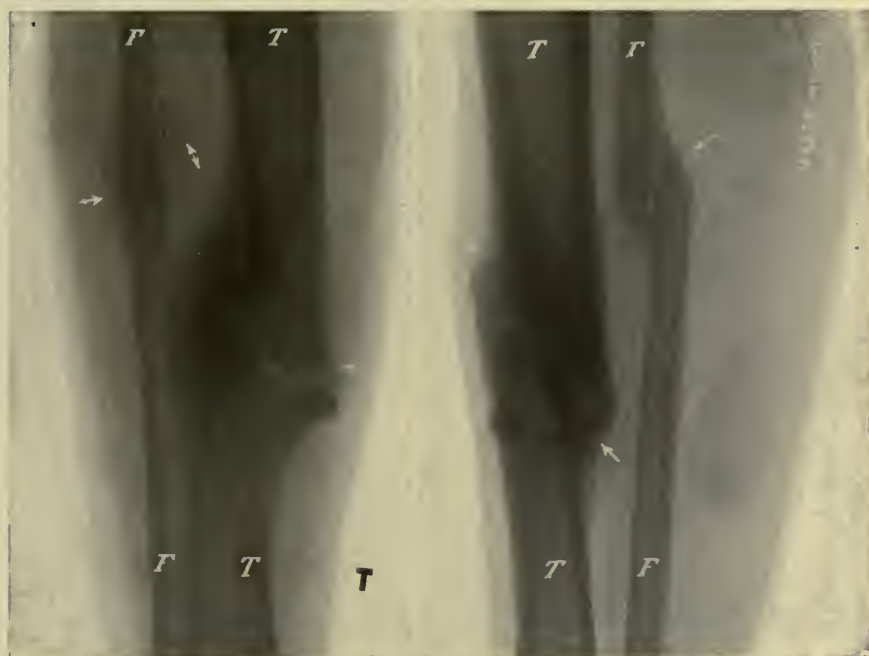

FIG. 142.—FRACTURE OF THE TIBIA AND FIBULA, TAKEN AT AN ANGLE BETWEEN THE ANTERO-POSTERIOR AND LATERAL POSITIONS.—This skiagram fails to show any overlapping of the fragments of the fibula, but exhibits the presence of callus.

FIG. 143.—Lateral view of the same, revealing a pronounced overlapping of the fragments. (Case of Dr. W. L. Rodman.)



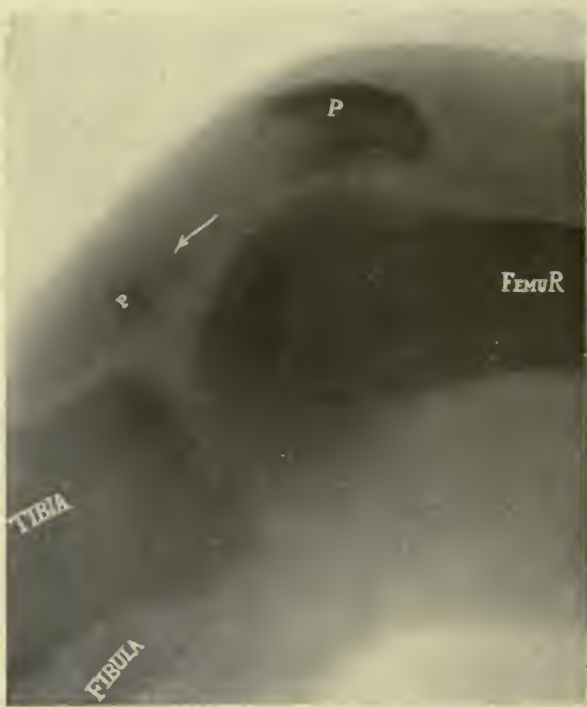

FIG. 144.—Fracture of the anterior portion of the patella.

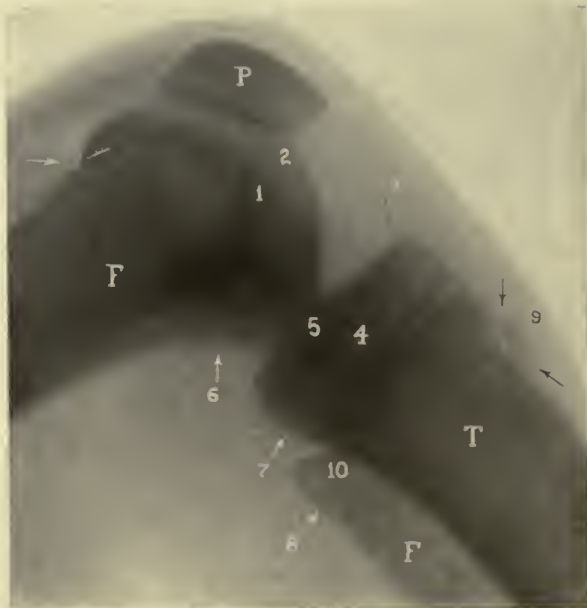

FIG. 145.—Detachment of the tubercle of the tibia, result of a kick in a game of foot-ball, —→ 9.  
(Case of Dr. Carlos M. Desvernine.)

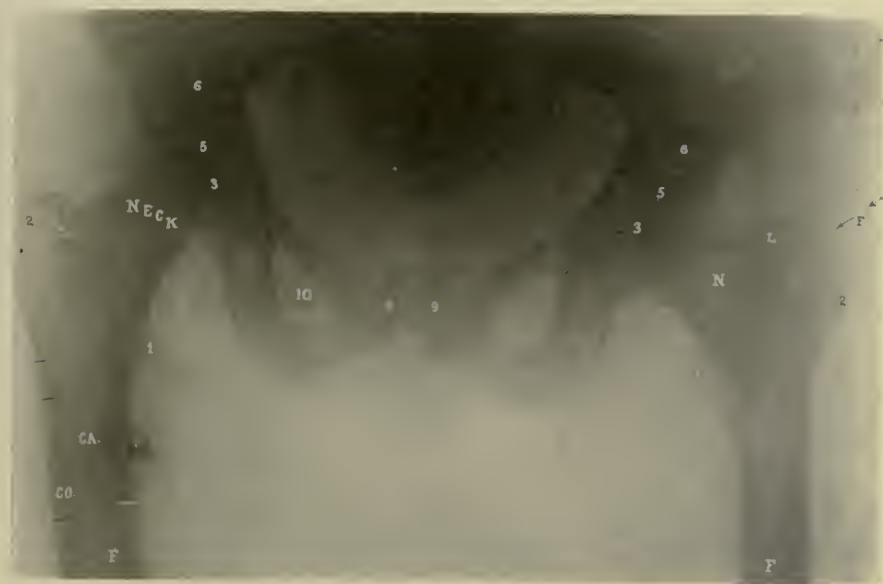

FIG. 146.—Incomplete intertrochanteric fracture. (Case of Dr. W. L. Rodman.)



FIG. 147.—CONGENITAL DISLOCATION OF THE HEAD OF THE LEFT FEMUR.—1, lesser trochanter; 2, greater trochanter; 3, head; 4, neck; 5, acetabulum. (Case of Dr. H. Augustus Wilson.)



FIG. 148.—CONGENITAL DISLOCATION OF BOTH HIPS.—This skilograph was taken by me after reduction by Dr. Adolf Lorenz of Vienna.



FIG. 149.—PATHOLOGICAL DISLOCATION OF LEFT HIP IN A CHILD OF SIX YEARS.—When one year old an abscess developed, which was incised and drained, and extension applied. Five years later the skiagraph, as shown above, revealed absorption of the femoral neck. On the normal side, N indicates the neck; this is wanting on the affected side (X). 1, lesser trochanter; 2, greater trochanter; 3, head of the femur; N, neck of the femur; 4 →, epiphyscal line; 5, acetabulum; 7, iliac fossa; 8, epiphysis between the ilium and ischium; 9, pubic bone; 10, obturator foramen; 11, ischium; 12, pubic arch; 14, ilio-pectinal line; 16 → 16, sacro-iliac synchondrosis; 17, crest of the ilium; 18, transverse process of the 5th lumbar vertebra; 19, fecal matter surrounded by light area (gas); C, coccyx. (Case of Dr. James K. Young.)



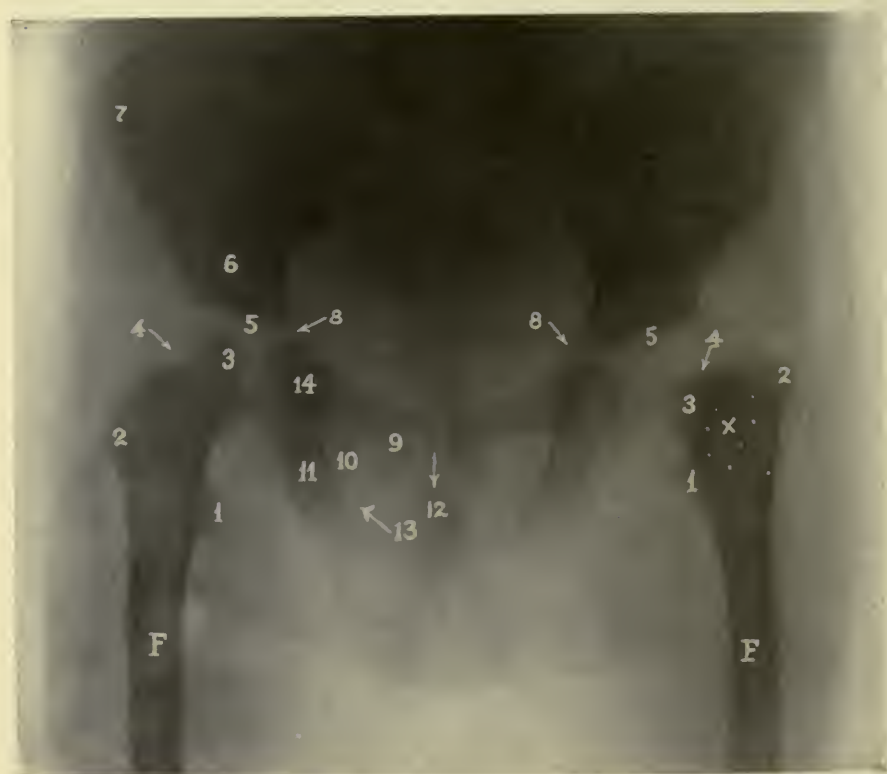

FIG. 150.—A CASE OF PROBABLE INFANTILE PALSY.—The patient's left femur (right side in the photograph) shows an absence of the neck, and also a transparent area at the dotted portion indicated at X. (Case of Dr. James K. Young.)

are of great diagnostic aid, as the contour of these bones is very irregular and the rays must traverse great density of structure. Fractures of the pelvic bones are divided into those in which the individual parts are fractured and those in which the pelvic rim is broken.

In skiagraphing the pelvis the patient must assume the ventral and dorsal decubitus positions. In a skiagraph of the sacro-coecygeal region the tube should be placed over the umbilicus so that the shadow of the pubic symphysis will not overlap the shadow of the sacrum or coccyx. The rectum should be emptied by an enema prior to the examination.

The ilium, iselium, and the pubes can be skiagraphed in the above manner, with slight modifications in the relation of the tube, the part, and the plate.

### THE SPINAL COLUMN.

For the sake of conveniently studying the spinal column, it is divided into the *cervical*, *dorsal*, and *lumbar* regions.

The *cervical* region is best skiagraphed in lateral view. Complete fracture of the cervical vertebræ can easily be shown in skiagrams, but incomplete fracture is detected with great difficulty. In my experience I have found the fifth and sixth cervical vertebræ are most frequently fractured. To demonstrate a fracture or dislocation, skiagrams should be taken in the lateral and the antero-posterior position. Recently I had two cases of old fracture-dislocations of the fifth cervical vertebra, and the patients are still alive. I have had four cases of fracture of the cervical vertebræ.

Skiagrams of the *dorsal* region are somewhat indistinct, due to the superimposition of shadows cast by the liver, heart, sternum, and ribs. I have had four fractures of the second and eleventh dorsal vertebræ. The best definition is obtained from the young and those of slender build. In thin persons antero-posterior dislocations may be shown by taking the skiagram in the lateral view. Of course distortion will be exaggerated on account of the distance between the plate and the vertebræ.

Experience proves that the obstacles encountered in making skiagrams of the vertebral column are numerous. Thus, the peculiar anatomical arrangement in this locality, the projecting and irregular processes from each vertebra, and the impossibility of obtaining the desired relations between the tube, the part, and the plate, make this procedure a most difficult one. The dorsal decubitus should be selected for examining all regions of the spine; but the tube should be placed at varying positions, and in this way the shadow of the sternum will be lessened in the dorsal region. This technic answers for the dorsal vertebræ, but the upper six cervical should be taken in the lateral view. Only one region of the spine can be skiagraphed at a time. In order to obtain the intra-articular spaces clear and distinct, it must not be forgotten that the alimentary

canal should be well cleansed previously. The negative must be sufficiently dense to bring out strongly and sharply the shadow of each vertebra with its processes. If this cannot be obtained, resort must be made to chemical intensification.

The technic employed for the *lumbar* region is in every way identical with the technic employed in renal skiagraphy (*vide*).

#### THE RIBS AND STERNUM.

Fractures of the sternum are best examined by skiagraphing in the ventral position. The ribs can be examined by the fluoroscope in different directions. The dorsal and ventral views will reveal the fractures and even slight fissures, but difficulty is encountered at the angles of the ribs, because of the difficulty in approximating the plate, and the necessity of the rays traversing diagonally the thickness of the body, and because of the respiratory movements.

The negative clearly reveals the presence of displacement. A slight fissured fracture may often escape detection. Care should be taken not to confuse the costo-sternal and costo-vertebral articulations with fractures. It must not be forgotten, in this connection, that the cartilages are transparent to the rays. Fracture of the ends of the floating ribs may be detected. The exposure must be short, and made preferably at the end of a prolonged inspiration, the patient holding his breath for five or ten seconds. Zinc-oxide adhesive plaster, if uniformly applied over the entire chest, immobilizes the part and aids the skiagrapher, but a few strips applied for this purpose may confuse the picture on the negative by casting shadows, in conjunction with those of the ribs.

Do not mistake the various grooves or prominences in the ribs for a fracture.

#### V. Diseases of the Osseous System.

As the osseous system is largely composed of mineral matter (calcium phosphate), the X-rays in their passage must suffer a marked absorption and their progress meet with great obstruction, causing decreased oxidation on the plate, and offering white shadows on the negative, thus greatly facilitating its study. Some think that the rays throw merely a shadow or silhouette of the bone on the plate, but the fallacy of this view is apparent. In studying the photograph of the humerus, for example, we see the superimposition of various strata of different densities; the compact portion appears denser than the medullary, because the rays in the former must traverse more osseous structure. In the medullary portion the negative gives a darker appearance, because the rays are only compelled to pass through two layers of bone, the medullary canal intervening. Ridges appear whiter, and fossæ darker, than the medullary portion, due to increased density; foraminæ show



as dark spots, while bony canals offer dark lines on the negative. Articular cartilages being transparent to the rays, and likewise the epiphyses, the shadows cast will be dark.

#### A. PATHOLOGICAL CONDITIONS.

Any pathological condition either in the organic or inorganic constituents will offer a corresponding change in the shadow thrown; the diseased portion of bone will cast a shadow lighter or darker than the surrounding healthy osseous tissue, and likewise of the same bone of the opposite side. In skiagraphing osseous tissue, care should be taken to ascertain the presence of diseased conditions of surrounding soft parts, such as an effusion, cyst, tumor, etc., as their presence might produce a dense shadow that could be interpreted as belonging to the bone. To corroborate the diagnosis, a skiagram of the corresponding part should be taken, with exactly the same technic, as difference in the position of the plate, the tube, and the part might cause a difference in the definition, shape, and size of the shadow produced. When possible, expose both parts simultaneously.

*Acute and Chronic Periostitis and Osteomyelitis.*—Periostitis is characterized by the presence of a fusiform thickening of the periosteum. This must not be mistaken for bony irregularities.

*Osteitis (osteo-myelitis)* is marked by an increase in shadow density. (Figs. 151, 152.) Eight or ten days after the injury suppuration occurs, and about the twelfth day disintegration of bone takes place, resulting in the production of a lighter shadow. Later, the skiagraph of a sequestrum will be revealed.

*Tuberculosis of Bone.*—This affection is characterized by numerous white irregular spots which have a natural tendency to coalesce. The shadow cast will be lighter than that of the normal bone, because the rays traverse less density, due to caseation and fibrous tissue formation. (Fig. 153.)

*Syphilis of Bone.*—In syphilis of the bone, two conditions are encountered,—the occurrence of rarefaction or an absorption of the compact bony structure, and a sclerosis, with an increase in density of the bone affected. The infected gummatous portions of the bone cast a lighter shadow than does the normal bone. When eburnation occurs the shadow cast will be darker, but the density of the shadow will not be uniform, an irregular thickening encroaching upon the medullary canal being evidenced. In the adult this condition is differentiated with difficulty from the thickening resulting from a chronic osteitis and periostitis. (Fig. 154.)

*Hypertrophic deforming osteitis (Paget's disease)* presents a hypertrophy of the compact tissue, manifesting a very dense shadow.

*Leprosy.*—Among the various bone lesions, transparency of the



digital phalanges is most frequent. This transparency is very pronounced in the distal phalanges, though it may be equally so in the others.

*Acromegaly.*—This affection may be more thoroughly understood by a careful investigation into the bony peculiarities of the skull. A great prominence of the external occipital protuberance, an irregular thickening of the cranial parietes, the over-development of the frontal sinuses and mental eminence, as well as the marked hypertrophy of the sella turcica, make this means of diagnosis of incalculable benefit. The shadows of the phalanges show the epiphyses to undergo an enormous hypertrophy and deformity, and to offer no obstruction to the rays.

*Rickets.*—In this disease the bone appears shorter than normal, the diaphysis slender, the epiphyses enlarged, and the line of calcification presents an irregular appearance. The delay in the process of ossification can be accurately determined.

*Cretinism.*—In this affection there is supposed to be a premature union of the epiphysis and the diaphysis, resulting in an arrested growth of the bone.

Langhaus and von Wyss<sup>1</sup> found that there is no hint of premature ossification in cretins and cretinoids, but a late development of the centres of ossification occurs, and consequently at or after the age of development, the epiphyses show a delayed union; this delay in the process of ossification, as compared with the normal individual, is of a few years only. The bones of the hand are the last to ossify. Hoffmeister, in treating a cretin, observed skiagraphically that when the child was treated with thyroid extract, the bones under examination grew 4 cm. in four months, equivalent to 12 cm. in a year, in comparison with the normal growth of 6 cm. annually.

*Osteomalacia.*—In osteomalacia the shadows of the bones will be transparent, and as the disease progresses there will be a complete absence of these shadows.

*Necrosis and caries* are characterized by transparent shadows, and irregularity in the contour and texture of the bone. (Fig. 155.) Far advanced cases will not cast a shadow. Skiagraphy of the sequestra is of marked service to the surgeon, informing him of their location, number, and relations to the bone itself and whether they are still adherent or exfoliated. Avoid the superimposition of their shadows with those of the bones.

## B. TUMORS OF BONES.

Skiagraphy enables us to determine if a neoplasm is connected with the compact or cancellous portion of the bone, or if it is connected with the bone at all. Thus, the growth might be a cyst or a myoma that closely simulates an osteoma, an osteo-sarcoma, etc.

<sup>1</sup> Fortschritte a. d. Geb. d. Röntgenstr., B. iii., 1899-1900.



FIG. 151.—Chronic osteitis with eburnation, as indicated by the arrows. (Case of Dr. M. P. Dickeson.)

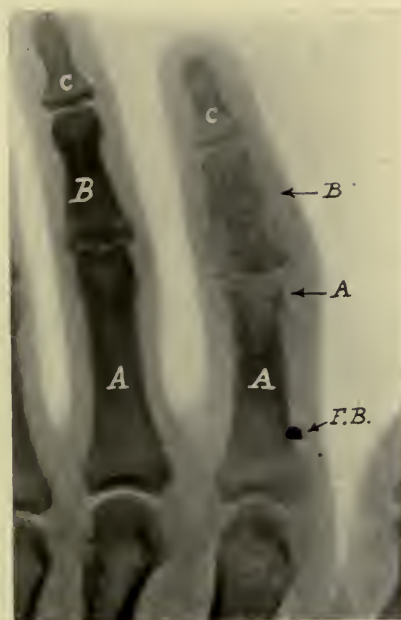

FIG. 152.—OSTEITIS OF THE INDEX FINGER—*F.B.*, foreign body which produced the condition; *A* ← was the point of entrance of the foreign body. (Case of Dr. Prendergast.)



FIG. 153.—TUBERCULOUS OSTEITIS.—The dotted area on the fourth metacarpal bone shows tuberculous invasion of the bone.



FIG. 154.—Syphilitic osteitis of the radius.

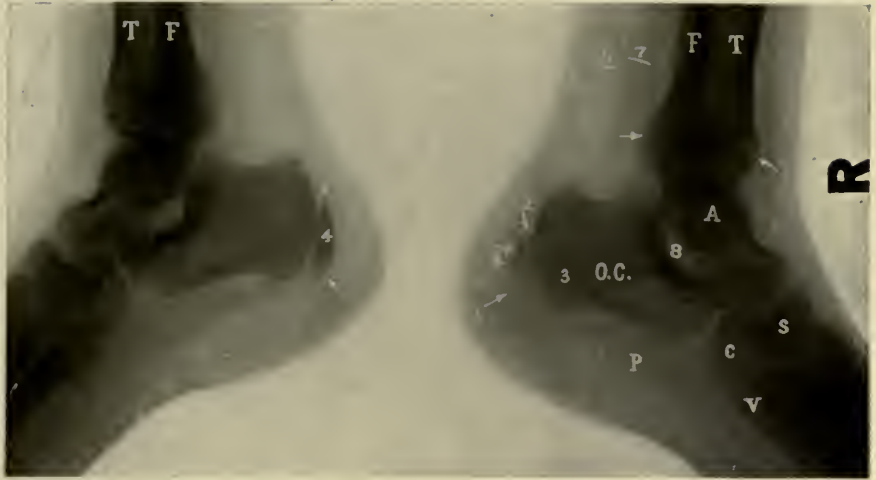

FIG. 155.—NECROSIS OF THE OS CALCIS.—Right-hand picture shows part of the foot of a patient who complained of intense pain in the heel, supposedly due to an ill-fitting shoe; but the X-rays revealed a necrosis of the os calcis, with partial absorption, indicated by 1. The left-hand picture shows the normal heel. 4 →, centre of ossification of the epiphysis of the tuberosity of the calcaneum; A, astragalus; 3 O.C., os calcis; 5, fat (dark on the negative); 6, tendo Achillis; 7, muscles; 8, sinus of the tarsus; P, plantar arch; C, cuboid; S, scaphoid; V, fifth metatarsal. (Patient under care of Prof. H. A. Wilson, service of Philadelphia Hospital.)

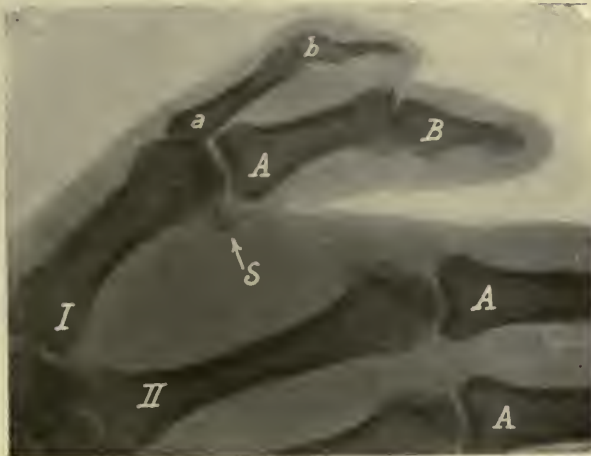

FIG. 156.—Supernumerary thumb. (Case of Dr. George M. Boyd.)





FIG. 157.—Congenital absence of the ulna and two fingers. (Case of Dr. W. Frank Haehrlen.)

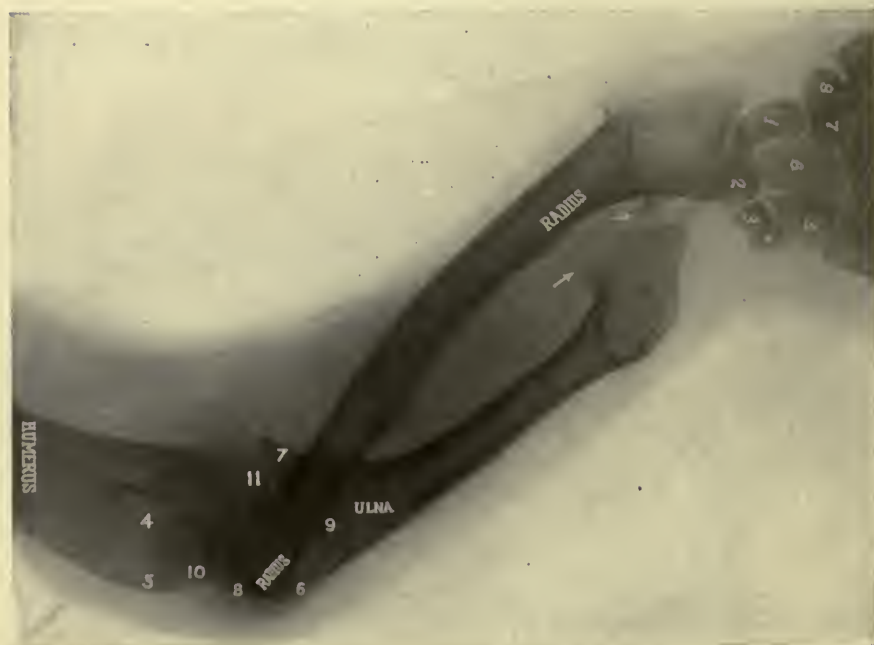

FIG. 158.—Congenital multiple exostoses. (Case of Dr. J. P. Mann.)

Osteo-sarcoma, like all osseous growths, may be of the periosteal or medullary variety.

In periosteal *sarcoma*, the growth may be observed to start laterally, but later to completely encircle the bone.

In the early stage the medullary form may be easily confused with syphilitic osteitis; in the latter the tendency is to be formation of clear spots, that later become multiple, while osteo-sarcoma begins with a single clear spot, becoming gradually enlarged; it is never multiple.

Metastatic *carcinoma* has been shown by Benedict<sup>1</sup> to affect osseous as well as the softer tissues. A patient under his care suffered from cancer of the kidney, and later had it removed. Four years subsequently, intense pain was diagnosed as sciatica, but the X-rays revealed a metastatic carcinoma of the last lumbar vertebra, which was later confirmed at post-mortem. *Bone cysts* can also be detected.

### C. DEFORMITIES OF BONES.

Among the more common deformities of congenital origin are supernumerary fingers, or the absence of one or all of the digits. (Figs. 156, 157.) There is usually either a second little finger (the most frequent) or a second but smaller thumb. We determine if the additional digit is simply tagged on by the skin, or if a distinct and completely developed articulation exists. In cases of supposed giant finger, the X-rays will indicate whether the bone or the surrounding tissue has undergone hypertrophy. In cases of syndactylism the skiagrapher can often determine whether bone itself partakes in the union. Hammer-fingers are of interest in that the joint itself is not diseased, there being only a contraction of the ligaments and tendons, as may be demonstrated by the fluorescent screen.

Exostoses show the normal compact and cancellous structures. (Fig. 158.) There is an overgrowth of the normal bone, the epiphyseal line presents a darker color, and from its margins spring peculiar, hook-like osseous projections.

These changes produce an alteration in the curvature of the bone, with atrophy of the epiphysis and arrest of the development of the diaphysis. Frequently a union of the bones (synostosis) occurs, but the growth is usually partially inhibited in one of them, resulting in a peculiar twisting, readily diagnosed and differentiated from rickets and other bone diseases.

Deformities of the pelvis and pelvimetry will be treated of in the article on Obstetrics.

Two interesting cases, studied by Dr. Charles W. Burr,<sup>2</sup> of congenital deformities were presumably due to intra-uterine disease of the spinal

<sup>1</sup> Wiener klin. Wochenschrift, June, 1899.

<sup>2</sup> Journal of the American Medical Association, June 11, 1904.

eord. (Fig. 159.) The first case was a male, fifty-five years of age, four feet tall; head and skin normal, no anæsthesia, sensation preserved all over the body; the reflexes were present. The legs and arms were deformed, and locomotion was prevented by weakness of the muscles. The epiphyses of the bones were distinctly abnormal, and the skiagraph showed marked absence of lime salts in the bones of the hands. The other case was that of a man, aged twenty-three years, in whom the shoulders, arms, and forearms had never developed, or there was a retrogression of development. The biceps jerk was absent; there was no disease of the bones; there was very slight wasting in the left leg, only detectable by measurement. Several theories had been advanced as to the cause of the condition, among others, bilateral brachial palsy from birth, malposition in utero, etc.; but the author was inclined to believe that possibly the patient had disease of the anterior horns of the spinal eord in utero.

*Diseases and Deformities of the Spinal Column.*—The more common pathological spinal curvatures are scoliosis, kyphosis, and lordosis.

In scoliosis the patient should assume the dorsal decubitus position. A skiagram of the kyphotic patient is difficult, because the plate cannot be properly approximated upon the part, necessitating a lateral view with the patient on his side. This, however, will not afford a very sharp definition of the shadow, as the plate is too distant from the part.

The same difficulty is encountered in lordosis; consequently in these cases the lateral view must likewise be employed.

*Torticollis.*—When the deeper muscles are diseased, it not infrequently happens that caries of the cervical vertebrae coexists. Its presence may be verified by a skiagram in both the antero-posterior and lateral views.

*Pott's Disease.*—It is difficult to differentiate the early stages of Pott's disease from intercostal neuralgia, renal disease, empyema with subdiaphragmatic abscess, etc.; but the skiagram will show the bodies of the vertebrae and the interarticular spaces to possess a denser shadow than normal. In advanced cases the disintegrated osseous tissue will present a dark, dense, irregular shadow. Place the patient in the dorsal decubitus position, have him flex the knees so as to straighten the spine as far as possible and thus bring it in closer relation with the plate. The above description applies to any region of the spine. Dark shadows in the right iliac fossa, often due to the accumulation of gases in the colon, must not be mistaken for necrosis of bone.

*Amputation Stumps.*—The process of healing can be systematically followed in cases of amputation stumps, by noting the existence or absence of a fine layer of compact bony tissue, covering the medullary canal, and thus the presence of a sequestrum, interfering with the healing, can likewise be detected.



FIG. 159.—DELAYED OSSIFICATION OF THE EPIPHYSES.—Patient 55 years of age. Every bone deformed. Unable to walk since childhood and had been in the hospital more than 30 years. No history of syphilis, and Dr. Burr of the Philadelphia Hospital believes the deformities to be congenital and due to disease of the spinal cord which developed during foetal life. The epiphyseal ends of the femora, tibiae, and fibulae look spongy from lack of ossification. Articular surfaces irregular, bones bent and pervious to the rays. The epiphyseal lines appeared darker because of excessive ossification.





*Resection of Joints.*—Before resecting a joint, the rays will determine the exact character of the affection, and their application after the wound has been dressed will inform the operator if the bones are in the best possible position.

*Regeneration of Bone.*—After removal of a portion of bone, the periosteum being left intact, the formation of new bone may be carefully observed, and the surgeon can often determine if the proper amount of osseous-forming structure has been deposited.

## VI. Diseases and Tumors of the Soft Tissues.

Tumors of the soft tissues, being only slightly opaque to the X-rays, are skiagraphed with great difficulty, owing to the surrounding structures having very nearly the same density. For this purpose we employ a hard tube with a short exposure, avoiding over-exposure and superimposition of the shadow of the bone. This may also be accomplished by diluting the developer and producing a soft negative full of details, or by an under-developed negative. The detection of the presence of a tumor by a skiagraph will be dependent largely upon the location, size, and consistency, and the technic employed.

In the order of the density of shadows cast, tumors may be arranged as follows :

Hæmatomata and Abscesses,  
Myomata,  
Enchondromata,  
Lipomata,  
Fibromata,  
Sarcomata,  
Carcinomata.

*Hæmatomata.*—The blood contained in a hæmatoma is more opaque to the rays than the surrounding tissue; hence the shadow cast will be darker. Hæmatomata may be differentiated from abscesses by the fact that the former present a greater density, especially when the blood is coagulated.

*Abscesses* cast dark shadows on the negative, but not to so great a degree as do the hæmatomata. In the extremities they are easily diagnosed, but in the abdominal cavity or cranium they are differentiated from other growths with great difficulty. Thus, during the past year I encountered many obstacles in skiagraphing a condition at the Philadelphia Hospital that resembled appendicitis, subphrenic and hepatic abscess. The negative revealed a diffused white spot in the position of the lower region of the liver. Dr. Joseph Hearn confirmed the diagnosis by operation. Dr. George Pfahler has recently reported to the Philadelphia County Medical Society the taking of a successful

skiagram of a subphrenic abscess. In January, 1905, I diagnosed skiagraphically, at the Philadelphia Hospital, a supposed hepatic abscess, but at a subsequent operation Dr. Ernest Laplace proved the affection to be cancerous.

Preutz, of Jena, in a study of 234 hepatic abscesses, speaks commendably of the great value derived from radioscopy. Myomata and fibromata are most difficult to skiagraph, especially in the uterus, where superimposition of the shadows of the pelvic bones interferes with a differentiation of the tumor from the surrounding tissues. Their shadows will be easily recognizable when the neoplasm is large, but manual palpation will detect this quite as readily as the skiagrapher can assert the presence of this condition. It is worthy of mention that skiagraphs can frequently detect the presence of myositis ossificans.

*Enchondromata*, being cartilaginous tumors, are difficult to skiagraph because of their transparency to the rays. When the phalanges are thus affected, the condition is clearly presented on the negative.

*Lipomata* are differentiated from solid and cystic tumors by their throwing a lighter shadow, because fat is less opaque to the rays than the above named neoplasms. X-ray diagnosis between a chronic abscess and a lipoma is quite as difficult as is the differentiation by clinical means.

*Sarcomata and carcinomata* cannot be differentiated by their skiagraphic appearance. They both cast equally dense shadows.

*Tumors of the Brain.*—The difficulties encountered in diagnosing skiagraphically cerebral neoplasms are due to the superimposition of the shadows of the tumor and the bony vault, the softened consistency of the pathological condition present, the distance of the shadow from the plate occasioned by the arching contour of the skull, and the production of secondary rays due to the marked density of

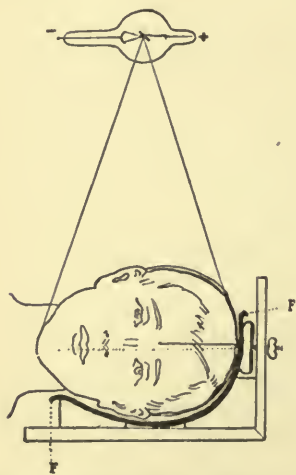

FIG. 160.—AUTHOR'S HEAD REST.—FF, flexible photographic film, conforming to the shape of the skull and employed for locating foreign bodies, etc., in the brain. A lead wire is run from the glabella to theinion and also over the position of the fissure of Rolando.

this particular region. Formerly I employed the photographic plate; more recently I used a board made in two sections that slide upon a base. (Fig. 160.) The boards are hollowed out to conform to the curvature of the skull, and may be so adjusted as to widen the concave excavation, and thus accommodate any size of skull. In this cavity is placed a double

coated gelatine film, and the patient's head is accurately accommodated to the shape of the cavity. This also insures steadiness of the part, so very important in this difficult procedure. Localization can be mapped out by placing metallic wires over anatomical landmarks.

The use of a compression diaphragm, for preventing the production of secondary rays, is largely in vogue in Germany, and has lately become popular in America, but this is undesirable, as the area skiagraphed is too small to allow of definite and logical conclusions.

The diagnostic value of the X-rays in neoplasms, abscesses, clots, etc., is less than in instances of the presence of foreign bodies. Extended literature on the subject is yet to be written.

Dr. Pfahler<sup>1</sup> gives an interesting account of a case of brain softening occurring in the service of Dr. Charles W. Burr. "This case," he says, "was one of thrombosis of the mid-cerebral artery, with cystic degeneration, and causing aphasia and hemiplegia. The examination was made post mortem. The brain was replaced and the skull and scalp closed. I then made a negative of the affected side and also of the opposite side, because I believed that possibly the normal side could be compared with the affected side. This case, however, demonstrated that this cannot be relied upon, for the lesion was shown upon both negatives, but with much more definite outline on the affected side. The skiagraph showed, above the cerebellum and petrous portion of the temporal bone, a light area which corresponded exactly with the outline of the area of degeneration. This skiagraph showed, also remarkably well, the convolutions of the cerebellum.

"The second case was also one of Dr. Burr's, in which an irregular area of degeneration was found in the distribution of the mid-cerebral artery and which had caused hemiplegia. The skiagraph showed transparent areas which corresponded exactly with the area of degeneration."

Dr. Pfahler<sup>2</sup> believes, that "we should be able to show in the skiagraph most large lesions, such as new growths, softening, hemorrhage, and abscess, but that we should never take the responsibility of an operation purely upon skiagraphic evidence."

Dr. Church, of Chicago,<sup>3</sup> records a case of cerebellar tumor in which the Röntgen rays were used by Mr. W. C. Fuchs. Skiagraphs of the tumor were obtained. At the autopsy a highly vascular gliomatous tumor was found, the tumor being the seat of several old and recent hemorrhages, and also of a recent clot of considerable size.

Obici and Ballici<sup>4</sup> demonstrated the presence of a tumor in a boy who died of brain tumor, the experiment being performed post mortem.

<sup>1</sup>The American Journal of the Medical Sciences, December, 1904.

<sup>2</sup>Ibid., December, 1904.

<sup>3</sup>Ibid., February, 1899.

<sup>4</sup>Rivista di Patholog., October, 1897, cited by Church.



They also experimented with tumors of different kinds placed in the brains of cadavers, and were in some instances able to obtain localizing shadows.

Oppenheim,<sup>1</sup> in reviewing the subject of brain tumors, remarks that his attempts with the X-rays for diagnostic purposes were unsuccessful, although he was enabled to determine that a tumor placed within the cranium upon the brain was distinctly noticeable.

Pancoast and McCarty<sup>2</sup> conclude that the value of the Röntgen rays in brain lesions is at present dubious.

Dr. M. Benedikt, of Vienna,<sup>3</sup> described a number of most interesting conditions that were both studied and skiagraphed by Dr. Kienböck. From a series of cases related by Dr. Benedikt we cull the following facts in his own words: "Kolar, M., engine-driver. On June 6, 1897, while leaning out of the engine, he struck his head against a lateral object. He lost consciousness, vomited, and was confined to his bed for six days. He tried to resume his work, but could not continue. On October 16, of the same year, he came for the first time under my observation. He complained of violent headaches, and his face had the rigid expression of a mask. On January 20, 1904, I had two profile diagrams taken with the Röntgen rays by Dr. Kienböck.

"When we ask what pathological process we must assume in this case, the answer is a pachymeningitis, especially hæmorrhagica, with all its consequences, also of alteration in the osseous parts. The enlarged shadow of the osseous circumference is not principally the result of thickening of the bones, but is produced also by pachymeningeal deposits."

"Bornstein Marcus met with an accident Dec. 24, 1903, while entering a railway car not yet lighted. He fell over a trunk and received a contusion on the tibia and on the index finger of the left hand. The nature of this accident seemed to point to a light lesion. To my great astonishment, at the examination (Jan. 4, 1904) serious symptoms were found. Standing with open and closed eyes the patient oscillated forward and to the left side. The supra- and infra-orbital nerves of the left side were sensitive to pressure, and the parietal, frontal, and temporal bones sensitive to percussion. In these localities the patient felt pains when he walked. The turning of the head excited pains, more toward the left than to the right side. The cervical and dorsal vertebræ were sensitive to pressure, the sensitiveness involving not only the processus spinosi, but also the lateral walls of the vertebræ on the left side. The pupil reflex was feeble.

"The left arm and both legs (especially the left one) were adynamic. The patellar reflex was feeble, and especially on the left side. The left ear was more sensitive to the tuning-fork, from the air and from the

<sup>1</sup> Diseases of the Nervous System, 1900. Translated by E. Mayer.

<sup>2</sup> University of Pennsylvania Medical Bulletin, March, 1903.

<sup>3</sup> The Archives of Physiological Therapy, February, 1905.

bones of the head. I was more astonished when Professor Reuss found beginning bilateral papillitis n. optici. The range of vision was much diminished concentrically, and in the left eye there existed a complete defect of vision in an inferior and superior sector.

“In this case the diagnosis was justifiable that there were serious anatomical intracranial lesions, and, as the case was a recent one, also blood effusions. Radiographs confirmed this diagnosis.”

I have successfully skiagraphed a blood clot in the brain, and I can do no better than quote the words of the late Dr. F. Savary Pearce, whose intense devotion to neurology and whose searching inquiry into the pathological manifestations of brain lesions made his word authoritative. In his article “Epiphenomena of Cerebral Hemorrhage,”<sup>1</sup> he says, “We would like to mention the possibility of the X-ray being a favorable adjunct toward determination of a blood clot within the brain or not, as a point in diagnosis between hemorrhage or thrombosis and this confusing class of Bright’s palsies. In a case coming to autopsy at the Medico-Chirurgical Hospital ten days ago, Dr. M. K. Kassabian had been fortunate enough to find what he thought was a ‘shadow’ of the thrombotic area in the left lenticulo-striate area region, and this proved to be so at the post-mortem examination. In this case, however, there was no complication of nephritis in making the clinical diagnosis.”

During 1904 and 1905, I skiagraphed at the Philadelphia Hospital a series of cerebral cases in the services of Drs. W. W. Keen, F. X. Dereuni, and Charles W. Burr. Realizing the imperfection resulting from the lightness of the shadow found in skiagraphing brain tissue, I took two skiagrams of suspected conditions and applied to the negatives obtained the principles of stereo-skiagraphy. The superimposition of the two views thus derived resulted in a clear-cut picture of the part under investigation.

Recently I skiagraphed a cerebral case at the Philadelphia Hospital. The patient’s skull was bandaged, thus concealing the presence of any abnormality. I was ignorant of his clinical history. When the plate was developed, I noticed in the motor region, a light area, the size of a goose’s egg. I then went to the ward to inquire as to the patient’s symptoms. I found that this special area was the one complained of; the result of a traumatism, which manifested itself in a slight paraplegia of the opposite side. This was undoubtedly an ecchymosis of the cerebral meninges. A false diagnosis was not probable, as there was no wet dressing or iodoform employed, no exudation of serum or blood, and likewise no pressure on the plate that might simulate such a diseased area. Subsequent examinations failed to reveal the affected region, although the skiagraph was taken under the same circumstances. Ultimately the patient got well, showing the ecchymosis (exudate) was absorbed.

<sup>1</sup> American Medicine, Aug. 9, 1902.

*Calcareous Deposits in Glands.*—The shadow thrown by these deposits is in some regions of the body dense enough to be mistaken for calculi. If there be an abscess cavity, sinus, or fistula, its depth and extent may be sufficiently ascertained by introducing either a probe, a packing of iodoform gauze, or a rubber drainage tube, and taking a skiagram while the introduced substance is *in situ*.

Empyema and pleural effusions will be treated of when discussing diseases of the thoracic organs.

Enlarged mediastinal glands, calcified glands, and bronchial glands are often visible.

## VII. The Articular System.

In the normal joint, the cartilage being transparent to the rays, the negative will show the inter-articular space black, but it will appear white on the skiagraph. The articular extremities of the bones will look smooth. In adjusting the tube, part, and plate, care must be taken to see that the rays fall directly upon the joint; for if this precaution be not taken, there will result an overlapping of the shadows of the articular extremities, the latter leading to a confusion, and causing a possible error between a diagnosis of the true condition, ankylosis, and subluxation.

As muscles, tendons, and ligaments are slightly less opaque to the rays than are the bones, the tearing off of any of these, as in some sprains, can sometimes be shown on the skiagram, provided that the shadow falls particularly on the muscular field, and that the negative is full of details, the result of good technic.

### A. DISEASES OF THE JOINTS.

*Acute Arthritis.*—In this affection the skiagram reveals nothing in the early stage, save a slight cloudiness or haziness at the inter-articular space, due to congestion. Later this haziness increases, and if pus be present, the shadow cast on the negative will be darker, as this is less opaque to the passage of the rays than is serum. If the arthritis continue for a few months, the inflammation will extend to the articular ends of the bone, and they will be more opaque to the rays, and consequently appear white on the negative.

*Acute and Chronic Articular Rheumatism.*—The acute stage is identical with the description given under acute arthritis. When this condition assumes the chronic form, the skiagram will show destruction of the articular ends of the bones, causing displacements of the opposed bony surfaces and the attendant deformities.

*Gout.*—In this disease the tophi (which are composed of sodium urate) are transparent to the rays. Yet peri-articular shadows of the tophi are often visible in the digits.



*Tuberculous Arthritis.* (Fig. 161.)—The early stages of tuberculous arthritis are most difficult to distinguish from other arthritic conditions. But as soon as the bone becomes involved the shadow on the negative will be identical with the appearance of tuberculosis of bone previously described; but with abscess formation, the dark spots on the skiagram will reveal the true nature of the malady. When destruction of the soft parts of the joint occurs with subsequent absorption of the head of the bone, sequestra are formed, resulting in great distortion.

*Coxalgia.*—In the incipient stage any haziness in the interarticular space, in comparison with the unaffected side, is indicative of changes in the synovial membrane of the joint,—this is likewise true of the epiphyseal line.

Lovett and Brown, in a most elaborate research,<sup>1</sup> arrived at these conclusions: “The earliest changes observed radiographically in hip disease are, first, diminution in the density of the shadow, and second, a relative diminution in the size of the shadow cast by the affected bone; in other words, atrophy of the bony substance.

“The best radiographic evidence is considered to be bony thickening, indicated by a shadow projecting inward from the pelvic side of the acetabulum; the head and neck of the femur also may show this evidence.

“Decreased radiability, observed as an indefinite, cloudy appearance, which involves not only the bony medulla, but the cortex and periosteal structures as well, is frequently seen. This cloudiness was found to be due to the presence of thick serum, pus, or finely divided detritus, and is apt to be misleading if depended upon to the exclusion of other indications. It was sometimes observed where the inflammatory process was extra-articular, as in abscess of the groin.

“Erosion of the bone substance, when present, is usually clearly evident on the plate, but is not of itself conclusive evidence that hip-joint disease is present.”

Loose bodies, such as displaced or detached cartilage, are difficult of detection because of their transparency. If their shadows are superimposed with those of the bones, recognition is of course impossible, as on the shadow of muscles, their detection, at times, is possible. Small sesamoid bones, which may simulate foreign bodies, can also be skiagraphed in or around a joint.

*Coxa Vara.*—“The neck of the femur varies in length and obliquity at various periods of life and under different circumstances. In infancy the angle is widest and becomes lessened during growth, so that at puberty it forms a gentle curve from the axis of the shaft. In the adult it forms an angle of about 130° with the shaft, but varies in inverse proportion to the development of the pelvis and stature. In consequence of the

<sup>1</sup> New York Medical Journal, January 28, 1905.



prominence of the hips and widening of the pelvis in the female, the neck of the thigh bone forms more nearly a right angle with the shaft than it does in man." (Gray.)

Skiagraphy in cases of coxa vara reveals the true clinical condition. (Fig. 162.) It is found that the axis of the neck to the shaft has materially changed its angle, that the affection is non-tuberculous, and that the trochanter has changed from its normal position to a higher plane. In skiagraphing this condition, inversion and eversion of the feet must be vigorously guarded against. This is best accomplished by securely binding both feet in the position of a right angle to the leg. A plate large enough to include both hips must be employed; the patient must lie absolutely flat on his back, with the tube placed over the pubic symphysis in the median line. Some operators prefer the ventral to the dorsal decubitus position. Of course, the position assumed will slightly vary the length of the neck of the bone. Consequently the necessity of comparison between the affected and the normal sides.

*Genu valgum* is the result of overgrowth of the inner condyle and an incurvation of the femoral shaft. The X-rays will show the amount and the angle of deformity, and also any alterations in the relaxation and elongation of the ligaments of the knee-joint.

*Genu varum* is the opposite of genu valgum, and in these cases the X-rays will also furnish the operator with complete clinical data.

Deformities of the foot, including talipes in its various forms, displacements of the toes, and deformities of the hands and digits can be most advantageously studied by corroborating the facts of clinical experience with the X-rays.

## B. ARTHROPATHIES.

In the early stages, arthropathies, as manifested in tabes (Fig. 163), present a haziness in the joint, identical with the appearance evidenced in other forms of arthritis. Later the interarticular space becomes more hazy, the periarticular structures are destroyed, the ends of the bones irregular and nodular, with rarefaction of the osseous tissue and possibly complete disappearance of the bone. In some instances, in place of rarefaction, we find thickening or eburnation, with the projection of bony excrescences.

*Syringomyelia*.—Several authorities<sup>1</sup> state, that in syringomyelia there is progressive destruction of the joints, greater in extent than is noticed in tabes, but marked by an absence of bony excrescences. Morvan's disease, often associated with syringomyelia and characterized by the formation of painless felons, shows skiagraphically an irregular appearance and a thickening of the bone, frequently with the presence of sequestra. Pulmonary tuberculosis and general systemic diseases may

<sup>1</sup> Bouchard, "Traité de Radiologie Médicale," 1904.



FIG. 161.—TUBERCULOUS ARTHRITIS OF THE KNEE-JOINT.—The left-hand picture shows tuberculous arthritis of the knee-joint; 4—5 indicates the distended capsular ligament; 3, a narrowing of the inter-articular space; 1 and 2 show the changed character of the epiphyses. The skiagraph was taken after the limb had been braced for two months. Right-hand picture shows the normal limb. (Case of Dr. J. K. Young.)



FIG. 162.—COXA VARA.—As a result of tuberculosis of the knee-joint. C, cast around the right knee-joint. (Case of Dr. James K. Young.)



FIG. 163.—Arthropathies of the knee-joint, in a patient with tabes dorsalis.  
(Case of Dr. Chas. K. Mills.)



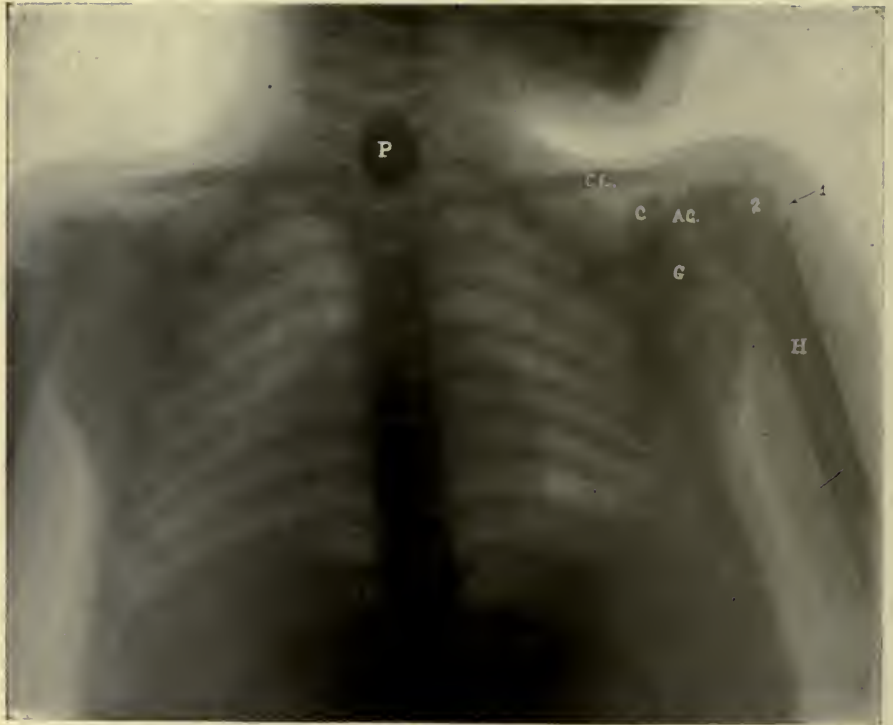

FIG. 164.—Penny in the esophagus.

also show arthropathies, but will not show the destruction of the articular ends of the bones, but there will be revealed a periarticular, semi-opaque condition.

### VIII. Foreign Bodies and their Localization.

In nothing have the X-rays proved themselves of more incalculable service than in the detection and localization of foreign bodies. Prior to the discovery of this priceless diagnostic agent, the surgeon found himself helpless in cutting down upon a supposed embedded substance, but with determination born of forlorn hope, too often he pursued an erroneous course, only to find that disappointment and at times serious infections were the rewards of his endeavors.

By the rays the skiagrapher learns not only the position of a foreign body, its variety, size, and shape, but also the extent of damage incurred.

#### A. MILITARY SURGERY.

The X-rays have been especially useful in military surgery. Dr. Haughton has said, "that the X-rays have furnished the army surgeon with a probe which is painless, which is exact, and, most important of all, which is aseptic."

In 1897 the X-rays were for the first time successfully used in the Græco-Turkish war. It was there demonstrated that they were an invaluable adjunct in military surgery, and since that time improvements have been made in the apparatus for trials in future field encounters.

The X-rays were also employed with marked success by Surgeon-Major Beevor on the Indian frontier, during the Chitral Campaign in 1898.

Of no less importance were the experiences of Major Battersby, who had charge of the Röntgen apparatus, while campaigning in the Soudan a number of years ago. Following the battle at Omdurman, 121 wounded British soldiers were brought to Abadith, 21 of whom could not have had their condition correctly diagnosed without X-ray examination.

In the words of Captain W. C. Borden, assistant surgeon in the United States Army:<sup>1</sup> "The use of the Röntgen rays has marked a distinct advance in military surgery. It has favored conservatism and promoted the aseptic healing of bullet wounds made by lodged missiles, in that it has done away with the necessity for the exploration of wounds by probes or other means, and has thus obviated the dangers of infection and additional traumatism in this class of injuries. In gunshot fractures it has been of great service from a scientific point of view, by showing the character of the bone lesions, the form of fracture, and the amount of bone comminution produced by the small calibre and other bullets,—

<sup>1</sup>The Use of the Röntgen Rays by the Medical Department of the United States Army in the War with Spain.

conditions which could not have been otherwise determined in the living body.”

Nicholas Senn writes that the expectations as to the diagnostic value of the X-rays in military surgery were actually realized in the Spanish-American War. He states that foreign bodies were located, fractures ascertained, and other surgical conditions studied, without subjecting the patient to pain or any danger from infection.

Mr. Clinton Dent,<sup>1</sup> special war correspondent in South Africa, speaks interestingly of injuries by Mauser bullets. If the dense part of the long bone is hit by a bullet of the Mauser type, there is a drilling, complicated by fracture. The extent of the injury depends upon the angle at which the bullet strikes the bone, upon the velocity of the bullet, and to some extent upon the age of the person. Mr. Dent also observes, “that a line drawn between the apertures of entrance and exit does not afford a reliable clue of the course that the bullet has followed.” He also states that fractures with a drilling of the tibia and the upper and lower ends of the humerus and radius are common.

Major Matignon, in reference to the Russo-Japanese war, describes at length<sup>2</sup> the installation of an X-ray apparatus in the Fifth Division of the Japanese army in Manchuria. This apparatus consisted of a Ruhmkorff coil, 30 cm. long and 12 cm. in diameter, with a spark-producing power of from 15 to 18 cm. The tube was bi-anodic and 20 cm. long. The current was supplied by a dynamo, energized by hand-power. Two persons were enabled to bring about sufficient velocity to produce the desired current by means of gearing. A portable dark room was provided, and Major Matignon remarks: “I was able to discern clearly the fractures and the presence of foreign bodies in the hand and in the arm.” He further states that the use of accumulators and their burdensome construction can thus be readily dispensed with.

## B. VARIETIES OF FOREIGN BODIES.

These may be transparent, translucent, or opaque to the rays.

The *transparent* include such substances as splinters of wood, pieces of coal, diamonds, paper wads, leather, clothing, etc.

The *translucent* include a fragment of porcelain, paste diamonds, small fish bones, other small bones, seeds of fruits, small pieces of glass, etc.

The *opaque* include metallic substances, such as bullets, coins, nails, buttons, pins, needles, jack-stones, marbles, and dice; also surgical dressings,—dusting powders (*e. g.*, bismuth, iodoform), lead-water and landanum, corrosive sublimate, dermatol, permanganate of potassium, etc., hard-rubber tubes, and iodoform gauze.

<sup>1</sup> British Medical Journal, April 21, 1900, p. 969.

<sup>2</sup> Archives d'Électricité Médicale, June 25, 1906.

The table below shows the relative transparency of equal thicknesses of various substances (water = 1) as found by Bottelli and Garbasso.<sup>1</sup>

TABLE OF PERMEABILITY OF RÖNTGEN RAYS.

MATERIAL.	SPECIFIC GRAVITY.	TRANSPARENCY.	MATERIAL.	SPECIFIC GRAVITY.	TRANSPARENCY.
Pine wood .....	0.56	2.21	Iron .....	7.87	0.101
Walnut .....	0.66	1.50	Chalk .....	2.7	0.330
Paraffin .....	0.874	1.12	Antimony .....	6.7	0.126
Rubber (pure gum) ..	0.93	1.10	Nickel .....	8.67	0.095
Wax .....	0.97	1.10	Brass .....	8.70	0.093
Stearine .....	0.97	0.94	Cadmium .....	8.69	0.090
Pasteboard .....	.....	0.80	Copper .....	8.96	0.084
Ebonite .....	1.14	0.80	Bismuth .....	9.82	0.075
Woolen tissue .....	.....	0.76	Silver .....	10.5	0.070
Celluloid .....	.....	0.76	Lead .....	11.38	0.055
Whalebone .....	.....	0.74	Palladium .....	11.3	0.053
Silk .....	.....	0.74	Mercury .....	13.56	0.044
Cotton .....	.....	0.70	Gold .....	19.36	0.030
Charcoal (hard wood) ..	.....	0.63	Platinum .....	22.07	0.020
Starch .....	.....	0.63	Ether .....	0.713	1.37
Sugar .....	1.61	0.60	Petroleum .....	0.836	1.28
Bone .....	1.9	0.56	Alcohol .....	0.793	1.22
Magnesium .....	1.74	0.50	Amyl alcohol .....	.....	1.20
Coke .....	.....	0.48	Olive oil .....	0.915	1.12
Glue .....	.....	0.48	Benzol .....	0.868	1.00
Sulphur .....	1.98	0.47	Water .....	1.000	1.00
Lead plaster .....	.....	0.40	Muriatic acid .....	1.260	0.86
Aluminium .....	2.67	0.38	Glycerin .....	1.240	0.76
Talc (soapstone) .....	2.6	0.35	Carbon disulphide... ..	1.293	0.74
Glass .....	2.6	0.34	Nitric acid .....	1.420	0.70
Tin .....	7.28	0.118	Chloroform .....	1.525	0.60
Zinc .....	7.20	0.116	Sulphuric acid .....	1.841	0.50

### C. FOREIGN BODIES IN THE DIGESTIVE, RESPIRATORY, AND GENITO-URINARY TRACTS.

*Œsophagus.*—Foreign bodies in this region can be detected by the fluoroscope and skiagram, and should be examined in both positions. I recently skiagraphed a child with a penny lodged in the œsophagus, as shown in Fig. 164.

Segond<sup>2</sup> reports a case where a tooth-plate had accidentally been swallowed and lodged in the œsophagus. It was located by the X-rays at the region of the supra-sternal concavity, and extracted by external œsophagotomy. A hook-like projection of the plate forced its way into the mucous and submucous coats of the organ, requiring repeated fluoroscopic examinations before extraction was achieved.

Mr. Ballance, of St. Thomas Hospital, London, says that by means of a fluoroscopic examination, a hat-pin was demonstrated in the

<sup>1</sup> Bolletino della Societa Fotografica Italiana, 1897.

<sup>2</sup> Lyon Médicale, August 5, 1898.



œsophagus of an infant fifteen months old. It had travelled to the lower third of the tract, where it had fastened itself. A gastrotomy was performed and the pin removed.

Dr. Nathan Raw<sup>1</sup> reports the swallowing of a tooth-plate by a lunatic. The foreign body had descended to a level just slightly below the inter-clavicular notch. The fluoroscope revealed the exact position, and also showed the plate with its longest diameter lying parallel with the transverse axis of the œsophagus.

*Stomach.*—Almost every variety of foreign body is found in the stomach, but the movement of that organ makes detection difficult. In skiagraphing the stomach, the patient should be placed in the ventral posture. Previously, he should have been cautioned against ingesting food and drink, as the former will increase the density of the shadows and the latter, in addition, offers an opacity to the rays. The foreign body is invariably found at the pyloric orifice.

Several years ago, at the clinic of the Medico-Chirurgical Hospital I demonstrated, by means of a skiagram, the presence of tacks, nails, and blades of pen-knives in the stomach of the "ostrich man."

W. S. Halsted<sup>2</sup> publishes a radiogram of a juggler's stomach, from which he removed 208 foreign bodies, including 20 links of dog-chain, 8 pieces of china, 7 knife-blades, 54 nails, and 35 wire nails.

Diamonds and small stones, being transparent to the rays, defy detection. Sometimes diamond thieves have swallowed the stones, but the latter could not be found either by fluoroscopy or skiagraphy. In many of the mints, suspected employés are subjected to X-ray examinations to detect the presence of stolen coins in the stomach.

*Intestines.*—In the intestines foreign bodies, such as coins, pins, nails, Murphy buttons, etc., can be seen gradually to traverse the bowel. The peristaltic action of the intestines often interferes with this detection. The skiagrapher is further hindered in the cases of children, their crying and moving presenting an additional obstacle. So long as the foreign body is being moved by peristalsis, the surgeon should not attempt to operate. It requires three or four days for a foreign body to be discharged. Skiagraphy is of special value in impaction of the rectum by foreign bodies, so commonly found in the hysterical and insane; it is also of utility in detecting foreign bodies in the appendix.

*Larynx, Trachea, and Bronchi.*—The foreign bodies lodged here are identical with those found in the stomach. The method of examination is likewise similar.

*Genito-Urinary Tract.*—Almost every conceivable variety of foreign body is to be found in the urethra and bladder of the male, and in the vagina, uterus, and bladder of the female. Recently I examined a patient

<sup>1</sup> The Liverpool Medico-Chirurgical Journal, September, 1901, p. 345.

<sup>2</sup> Johns Hopkins Hospital Reports, 1900, vol. ix. p. 1054.

for fractures of the femora, but instead I discovered a forgotten pessary. Forgotten pessaries have often been detected by the X-rays, when the cause of the suffering baffled the skill of the attending physician.

*Foreign Bodies Entering from Without.*—These include bullets, needles, cinders in the eye, broken ends of instruments, etc. In surgery we have, in addition to the retention of instruments in the cavity of the wound, a slipping in of a forgotten section of drainage-tube, and the closure of a wound without removal of iodoform gauze, etc.

#### D. THE X-RAYS IN OPHTHALMOLOGICAL SURGERY.

*Foreign Bodies in the Eye.*—The use of the X-rays in ophthalmology is principally confined to the detection and localization of foreign bodies in the eye. Dr. Van Duyse was perhaps the first to perform experiments for locating foreign bodies in the eye, and in March, 1896, he communicated his results to members of the Medical Society of Gand.

His first work consisted in the introduction of a small bullet into the eye of a rabbit, carefully pushing it up posteriorly to the iris. He produced an exophthalmos, and by slipping under the exophthalmic globe a small sensitive plate, he was able to define a shadow of the contained foreign body. By another experiment he proved that metallic bodies in the anterior chamber could be very easily demonstrated by placing a sensitive film of proper shape and size between the eyelids at the inner canthus and allowing the rays to penetrate the globe from the temporal side.

Dr. Leukowitsch<sup>1</sup> detailed his experiments and results on sheep's eyes, with the use of two tubes. He contended, however, that better results had been obtained by the use of one tube only. In experimenting on the human eye, he employed small sensitive plates, semicircular in shape, thus permitting the largest possible area being introduced at the inner angle of the eye opposite the lacrymal bone. A large part of the eyeball can readily be brought within easy range of the rays by simply rolling the eyeball. Rotation of the ball caused a point of fixation, which was obtained by employing a glass indicator bent into two right angles, a short and straight terminal so placed as to point exactly to the antero-posterior axis of the cornea's centre.

Dr. Max J. Stern, at the Philadelphia Polyclinic,<sup>2</sup> proved that a foreign body in any part of the eyeball could be shadowed on the plate at the side of the head, and radiographed four patients with steel in the eyeball. He determined the approximate positions of the metal in the eye from a study of the shadow of the body in relation to the shadows on the plate of the orbital bones; but the variation in the position of the eyeball in the orbit rendered this method liable to considerable error.

<sup>1</sup>The Lancet, August 15, 1896.

<sup>2</sup>Trans. Amer. Oph. Soc., 1896.

In February, 1897, Drs. Ring and Hansell each reported one case, and Dr. de Schweinitz two cases of steel particles in the vitreous located by the X-rays. In one of these cases two previous unsuccessful attempts had been made to extract the steel, and it was only after the radiographs indicated its approximate position that it was extracted by the magnet. These cases were probably the first that demonstrated that the bony walls of the orbit and the coats of the eye were permeable to the rays. By comparison of the shadow of the metal with that of the margin of the malar process of the superior maxillary bone, and the knowledge of the relation of the Crookes tube to the sensitive plate, the location of the foreign body could be easily demonstrated.

Dahlefeld and Pohrt<sup>1</sup> report that good records were obtained of small fragments of wire and small shot that had previously been introduced into the orbits. Their method of detection consists in placing a focus tube on the opposite side of the head (10 to 15 mm. distant from the temple) and a sensitive plate against the temple corresponding to the affected side.

Fridenberg<sup>2</sup> and Friedman<sup>3</sup> both made two exposures of the eye and orbit at right angles to each other, while Stockl<sup>4</sup> used pieces of lead, fastened at various points around the orbital margin, from which to measure the situation of the foreign body. Leonard made a number of exposures to give a series of triangles to locate the body.

For the want of space, I shall include only those methods which in my experience have been found most useful.

Dr. Wm. M. Sweet<sup>5</sup> was the first to devise an accurate method of localization, employing for this purpose a plate-holding apparatus, fixed to the side of the head on the injured side, the fixed points of measurement consisting of two ball-pointed rods, adjusted at a known distance from the centre of the cornea.

In describing the method, Sweet<sup>6</sup> says: "The determination of the location of pieces of metal in the eye or in the immediately adjacent tissues by means of the Röntgen rays demands that the shadow of the foreign body as shown on the radiograph be studied in relation to the shadows of at least two opaque objects of known position. The method of judging the approximate position of the body in the eye from the relation of its shadow on the photographic plate to the shadows cast by the bones of the orbit is less accurate than the method by triangulation, even when carried out by making two exposures upon the same plate with the tube in different positions, or by making several separate exposures."

<sup>1</sup> Deutsche medicinische Wochenschrift, No. 18, 1897.

<sup>2</sup> Medical Record, May 15, 1897.

<sup>3</sup> Klin. Monatsblatt, Oct. 1897.

<sup>4</sup> Wiener klin. Wochen., No. 7, 1898.

<sup>5</sup> Trans. Amer. Ophth. Society, May, 1897.

<sup>6</sup> Diseases of the Eye, by Hansell and Sweet.



The localizing apparatus designed by Sweet consists of two metal indicators, one pointing to the centre of the cornea and the other situated to the outer canthus at a known distance from the first. Two exposures are made in order to give different relations of the shadows of the indicators and of the body in the eyeball, one with the X-ray tube horizontal or nearly so with the plane of the indicators, and the other with the tube below this plane.

“The principle of the method may be understood from the perspective drawing (Fig. 165). Rays coming from the light situated at A cast

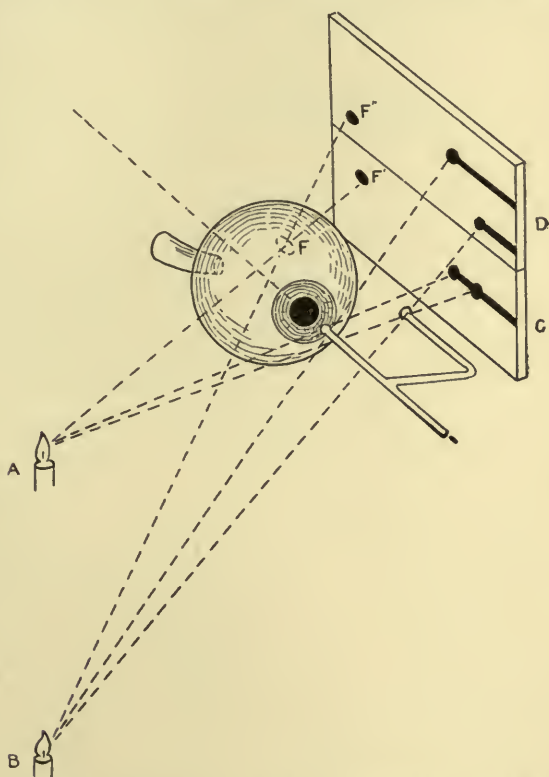

FIG. 165.—Principles of the method of localization. (Courtesy of Dr. Wm. M. Sweet.)

shadows of two ball-pointed rods and an object in the eyeball, and give the view shown on the surface C. In this instance the tube is in front of the vertical plane of the two indicators, and consequently the shadow of the centre ball will be thrown back of that of the outer ball. When the light is carried below the plane of the two indicators, the shadows of the two rods are formed on the surface D, and the shadow of the foreign body in the eye assumes a new position. If the distance of one of the indicating rods from the centre of the cornea is known, and the distance



between the two indicators is measured, the position of the metal in the eye may be determined, since the shadow of the foreign body preserves at all times a fixed relation to the shadows of the indicating balls, in whatever position the light is placed.

“Accurate localization requires that the axis of the eyeball shall be parallel with the two indicators and with the photographic plate, that one of the indicating balls be opposite to the centre of the cornea and at a known distance from it, and that both indicators are at a measured distance from each other. The plate-holder and indicators have been combined into a special apparatus which firmly holds the head of the patient, as shown in Fig. 166. The arrangement of the parts of this

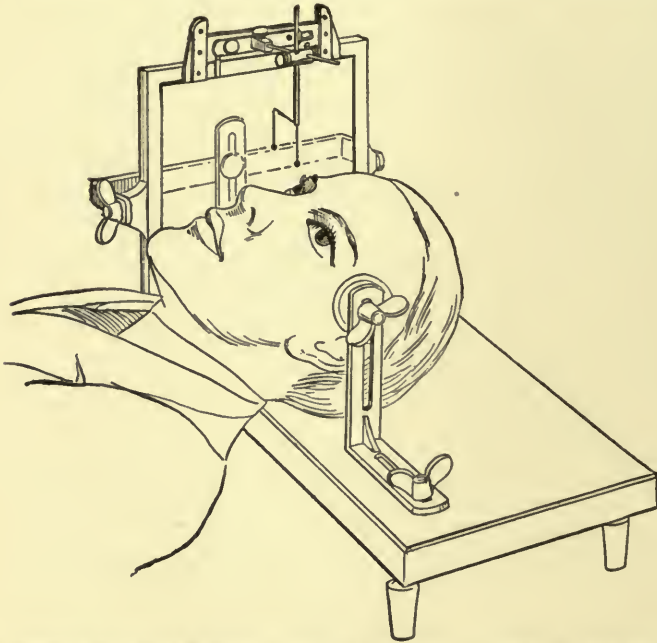

FIG. 166.—Indicating apparatus secured to the side of the head. (Courtesy of Dr. Wm. M. Sweet.)

apparatus is such that the indicators, while freely adjustable, are always parallel to each other and to the plate, and the two balls are perpendicular to the plate and 15 cm. distance between their centres when the apparatus is in place. It is necessary that the patient rotate the eyeball to bring the ocular axis parallel with the plane of the photographic plate, and that the operator adjust the indicators so that the centre ball is opposite the centre of the cornea.

“To determine the position of the foreign body in the eye, two circles are drawn, representing the horizontal and vertical sections of the normal adult eyeball, and upon these are marked the situations of the indicating balls at the time the radiographs are made.

“Lines are drawn through the shadow of each of the indicating balls on the two radiographs. On the negative made with the tube horizontal and parallel with the plane of the indicators, a measurement is made of the distance the shadow of the metallic body is above or below the shadow of each of the indicators. This distance is entered above or below the spots representing the two indicators on the diagram of the vertical section of the eyeball. Thus, in the radiograph (Fig. 167) the distance of the foreign body (S) below each of the indicators (O S and N S) is entered below the spots A and B, front view, Fig. 169. A line drawn through the points C and D gives the direction of the X-rays at the time the shadow of the foreign body was cast upon the plate. Similar measurements of the distance that the shadow of the foreign body is below the shadow of each of the indicators are made on the second negative (Fig. 168), and these are likewise entered below the points A and B, representing the two balls on the vertical section of the eyeball. These

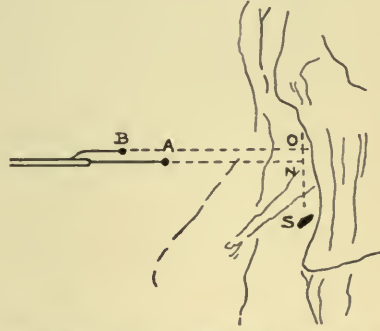

FIG. 167.—Outline drawing of a radiograph, made with a tube slightly above the plane of indicators. A, ball opposite the centre of the cornea; B, ball to the temporal side; S, foreign body. (Two-thirds normal size.)

measurements are A F and B E. A line drawn through the points E and F gives the direction of the rays when the second negative was made. Since these two lines indicate the plane of the shadow of the foreign body at each exposure, the intersection of the lines must be the location of the metal in the eye, as measured above or below the horizontal plane of the globe and to the temporal or nasal side. To determine the distance of the foreign body back of the centre of the cornea, the negative made with the tube horizontal is taken, and the distance is measured that the shadow of the ball opposite the centre of the cornea lies posterior to that of the external ball. This distance is entered directly

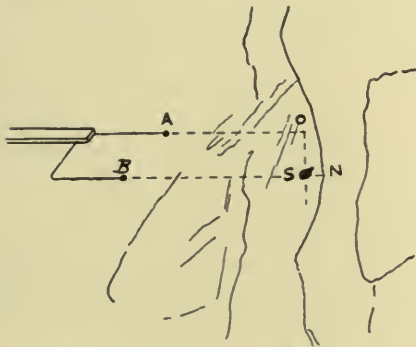

FIG. 168.—Outline drawing of radiograph, tube below the plane of indicators. A, ball below centre of the cornea; B, external ball; S, foreign body. (Two-thirds normal size.)

measurements are A F and B E. A line drawn through the points E and F gives the direction of the rays when the second negative was made. Since these two lines indicate the plane of the shadow of the foreign body at each exposure, the intersection of the lines must be the location of the metal in the eye, as measured above or below the horizontal plane of the globe and to the temporal or nasal side. To determine the distance of the foreign body back of the centre of the cornea, the negative made with the tube horizontal is taken, and the distance is measured that the shadow of the ball opposite the centre of the cornea lies posterior to that of the external ball. This distance is entered directly

above the external ball on the diagram representing the horizontal section of the eyeball. A line drawn from K through the centre ball gives the direction of the rays at the time the radiograph was made. On the same negative is measured the distance that the shadow of the foreign body is back of the shadow of each of the indicators, and these distances, B J and A H, are entered on the diagram. A line is drawn through the points J and H, and since this line represents the plane of the shadow of the foreign body, the point at which a perpendicular drawn from the situation of metal as shown on the vertical section of the eyeball intersects this line indicates the situation of the body

Name \_\_\_\_\_

Size of body \_\_\_\_\_ by \_\_\_\_\_ by \_\_\_\_\_ mm.

Date \_\_\_\_\_

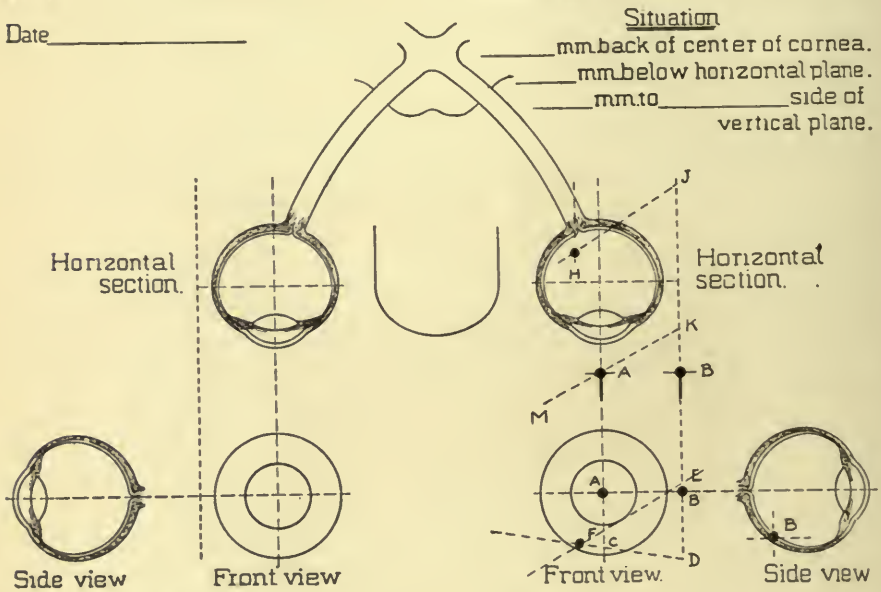

FIG. 169.—Dr. William M. Sweet's chart for plotting location of foreign bodies in the eye. (Two-thirds normal size.)

back of the centre of the cornea. If the position of the tube from the eye has been measured, its distance is indicated on the line drawn from K through the centre ball A. A line through J to this point indicates the divergence of the rays. This means of determining the position of the plane of shadow of the foreign body is more accurate than when the measurement is made of the shadow of the body above each of the balls, and should be followed, especially if the body is some distance away from the anterior segment of the globe or is in the orbit.

“If the foreign body has passed into the orbit, the rotation of the eyeball to insure parallelism of the ocular axis with the plane of the plate leads to a slight error in the determination of the position of the



metal. To eliminate this error necessitates a knowledge of the angle of the orbit with the plate or, its equivalent, the amount of deviation of the eyeball from the primary position, and the consideration of this angle in plotting the diagrammatic circles representing the eyeball.

“The indicating apparatus is secured to the side of the head corresponding to the injured eye, and the tube placed about 12 or 15 inches (30 or 38 cm.) to the opposite side and slightly forward. The patient is in the recumbent posture, to insure steadiness of the head. After the

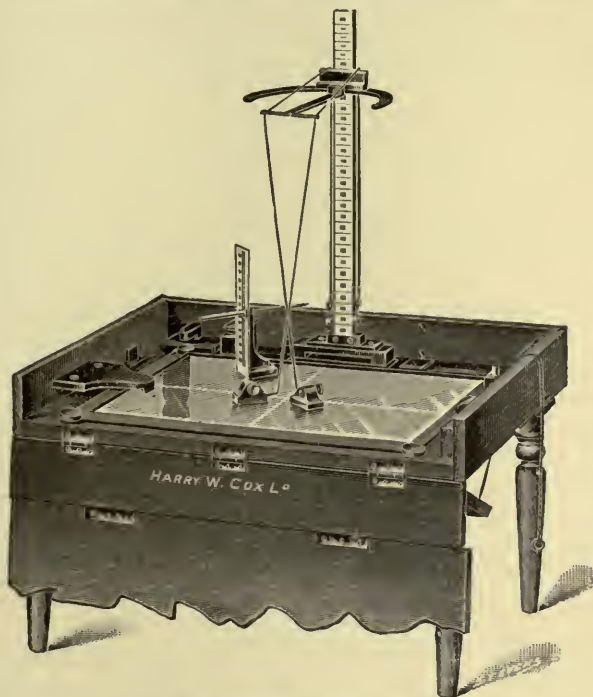

FIG. 170.—Mackenzie Davidson's localizer.

indicating rods have been adjusted, the patient fixes an object about 5 to 10 feet distant, so placed that the visual axis of the injured eye shall be parallel to the photographic plate. An exposure of from 10 to 20 seconds will clearly outline the bones of the orbit, and secure a shadow of any body opaque to the rays in the eyeball or in its neighborhood.”

Another method of equal accuracy was introduced by Mackenzie Davidson, who published a description of it in the *British Medical Journal*, January 1, 1896.

*Davidson's Method.* (Fig. 170.)—The theory of this method briefly is as follows:<sup>1</sup> “The Crookes tube is placed in a holder, which can slide horizontally. A perpendicular is dropped from the point in the anode of

<sup>1</sup> The Archives of the Röntgen Ray, May, 1898.



the tube where the X-rays originate on the point where two wires cross each other at right angles, and one of the wires must be parallel to the horizontal bar along which the tube-holder slides; so that, when the tube is displaced along the bar, a perpendicular dropped from the X-ray point in the anode would always fall upon this wire. The wires in reality represent two planes at right angles to each other, and the photographic plate representing the third plane. Eventually I obtain the three planes which are at right angles to each other, and whose relation to the part of the patient's body skigraphed is known.

"For practical purposes it is convenient to have the wires stretched across a flat board or sheet of vulcanite, and this can be placed on a table in the correct position below the horizontal bar, and fixed to the table by means of drawing pins. The wires being inked so as to mark the skin, a photographic plate, enclosed in black paper in the usual way, is placed beneath the cross wires. The perpendicular distance from the anode to where the wires cross each other is carefully measured and noted.

"It is now necessary to decide at what distance apart the tube is to be displaced in order to take the two skiagrams. It does not matter greatly,  $2\frac{1}{2}$ , 5 or more inches (6 to 12 cm. etc.) of displacement may be given. Having decided this point, movable clips are so placed as to limit the sliding of the tube-holder to the required extent. The tube is then displaced to one side, and the patient places the part to be photographed on the cross wires, being careful not to move, once the skin has come in contact with the wires; because it is of the utmost importance that the shadow of the cross-wires on the negative should be in register with the ink mark left on the patient's skin. Further it is convenient to put a small coin on one corner of the plate, and also mark the patient's skin nearest to it. This reveals to the operator the relation of the plate to the skin.

"One exposure is made, and the tube is then displaced. A second exposure is given, preferably on the same plate, provided a suitable apparatus be used to enable the plates, if a different plate be used, to be changed without disturbing the position of the parts at all.

"Having developed and fixed the negative, it will show a single shadow of the cross-wires, but two shadows of the foreign body. In order to interpret this correctly, I devised the following apparatus, which may be called the 'cross-thread localizer':

"A sheet of plate glass is fixed horizontally, having two lines marked upon its surface, crossing at right angles in the centre. A mirror hinged below it allows the light to be reflected from below, so as to render details on the negative visible by ordinary light.

"A scale fastened to a horizontal bar slides up and down on two rods which support its ends. The scale has small notches opposite its marks. This is so placed that a perpendicular dropped from the  $O^\circ$  or middle point of the scale falls exactly where the lines cross on the glass

stage. Furthermore, the edge of the scale is parallel to the line running right and left on the glass. The negative is now placed upon this glass stage, the operator being careful to bring the shadow of the cross-wires into register with the cross on the stage, placed with its marked quadrant in correct position. The gelatine surface can be protected by a thin transparent sheet of celluloid.

“The scale is now raised or lowered so as to bring the  $O^\circ$  precisely the same distance above the negative as was the anode of the Crookes tube when the negative was produced. All that is now necessary is to place a fine silk thread through the notch on one side of the  $O^\circ$  on the scale, and another thread through a notch on the other side, at exactly the same distance as that which measured the displacement of the X-ray tube.

“Small weights are attached to the ends of the two threads to keep them taut, while the other ends are threaded into fine needles fastened to pieces of lead. Thus the needle with the thread can be placed upon any point of the negative and remain in position. In short, the negative is now relative to the cross-lines, the scale, and the notches from which the two threads come, exactly the same as it was to the cross-wires and Crookes tube when being produced.

“A needle with the thread is placed upon any point on one of the shadows of the foreign body, and the other needle is placed upon a corresponding point in the other shadow, and it will be found that the threads cross each other, just touching and no more. The point where they cross represents the position of the foreign body. A perpendicular can be dropped from this point to the negative below, and a mark made at the point where it touches the negative. Then with a pair of compasses, the distance of this point from the two cross-wires can be measured.

“The height of the plate where the threads cross gives one co-ordinate, that is the depth of the foreign body below the skin, which rested on the photographic plate. The other two measurements give the other two co-ordinates.

“As the mark of the wires is left on the patient's skin, all that is required is to measure the two co-ordinates on the skin that give the point below which the foreign body will be found at the depth given by the third co-ordinate.”

*Grossman's Method of Localizing a Foreign Body in Eye.*—Karl Grossman,<sup>1</sup> in localizing a foreign body in the eye, utilized the eye itself for the purpose of obtaining the necessary parallax of the shadow; the vacuum tube, the head of the patient, and the photographic plate retain their relative positions to one another unchanged. He describes this method as follows: “Either one or two pairs of skiagrams are taken.

<sup>1</sup> Liverpool Medico-Chir. Journal, January, 1899, pp. 359-361.



The first pair is obtained by making the patient look (*a*) downward, (*b*) upward, in the same plane, the X-rays coming from the other side of the face and somewhat in front of it. If the foreign body be in the eyeball, the shadow has moved from (*a*) to (*b*) as follows: upward if in the anterior half-hemisphere, downward if in the posterior half-hemisphere, forward if in the inferior half-hemisphere, backward if in the superior half-hemisphere; the axis of these four half-hemispheres being at the same time the axis of rotation for the upward movement.

"If the shadow has not moved, the foreign body might still be in the eyeball,—*viz.*, at any point on the axis of rotation. In this case the second pair of skiagrams would become necessary, the patient this time having to look at a point (*c*) temporalward, (*d*) nasalward, in the horizontal plane. A movement of the shadow from (*c*) to (*d*) would mean the presence of a foreign body in the eye,—*viz.*, in the temporal hemisphere if forward; in the nasal hemisphere if backward. The relative position of the tube, head, and plate need only remain the same for the two exposures of each pair,—*viz.*, for (*a*) and (*b*) on the one hand, and for (*c*) and (*d*) on the other,—but may be a different one for each."

*Fox's<sup>1</sup> Method of Localization.* (Fig. 171.)—Briefly this method consists first of cocainizing the eye and in the introduction, beneath the lids, of an appliance called a "conformer." This device consists of an elliptical wire of gold, divided by cross-wires of gold (concaved on one side so as to slip over and fit the anterior surface of the eyeball) running in opposite axes, dividing the eyeball into quadrants, anteriorly. The next step in this method consists in skiagraphing the eye in two directions, so as to get good imprints on the sensitive plate of both the foreign body and the conformer. Thus, we produce a skiagram in the anterior diameter, placing a small sensitive plate in front and against the eyeball, and the tube in back of the head, with the target pointing in the direction of the eyeball. The tube should be distant from the sensitive plate 22 to 30 inches (55 to 75 cm.). The time of exposure is from 1½ to 2½ minutes, depending, of course, upon the thickness (or rather the antero-posterior diameter) of the head examined. With a properly exposed plate and a correctly developed negative, there will result a picture showing the relation the foreign body bears to the dividers of the conformer. A second skiagram is produced by placing the sensitive plate against the temple corresponding to the side that is to be examined, and the tube on the opposite side, with the target pointing in direct line with the temples. The tube should be from 20 to 30 inches (50 to 75 cm.) distant from the sensitive plate. The time of exposure should be from 1 to 1½ minutes, depending upon the thickness of the head in this diameter. This skiagram shows the depth of the foreign body, measured from the peak or base of the conformer.

<sup>1</sup> Philadelphia Medical Journal, February 1, 1902, pp. 213-220.



FIG. 171.—FOX'S LOCALIZER.—Bullet in the orbit: *S* →, shot. The wire over the cornea illustrates Fox's method of localization. 1, frontal sinus; 2, thickness of frontal bone; 3, the zygoma; *N.B.*, nasal bone.





This method is entirely different from any of the others, and, unless great care is exercised in securing the exposures at right angles to each other, the chance for error in localization is great. Prior to this method I placed the conformer over the closed eyelids.

#### E. VARIOUS METHODS OF LOCATING FOREIGN BODIES.

*Screen Method.*—This was the first method employed. In order to attain the best results, the examiner should have had thorough experience in this line of work. The fluoroscope should first be used, to demonstrate the presence of the foreign body. The hood is next removed from the screen, and the latter used separately, in the same position as when first located. A mark, made by an indelible pencil, is placed on the part directly over the spot where the shadow of the foreign body presents itself, this mark being directly behind the screen.

A second mark is made on the opposite side of the member corresponding to the area of the foreign body. These marks, lying in an even plane, should be both marked "1" and "1."

The depth of tissue in which the bullet lies is next ascertained by moving the screen slightly up and down; if the shadow of the foreign body moves considerably, it indicates that the foreign object is deeply imbedded. On the contrary, if the shadow moves but slightly, it indicates that the object is superficially imbedded. The next step consists in viewing the foreign body at exactly right angles to the first position; to do this the part under examination, and not the tube, should be turned. The skin of the part should be marked over the area of the shadow at both sides by the figures "2," "2." Next in order draw lines from 2-2 and 1-1, and the point of intersection corresponds to the exact location of the foreign object. For marking the skin, some prefer diluted silver nitrate crayons, but, as they are more or less irritating, I employ indelible pencils. Fig. 172 illustrates a simple method of localization.

*Punctograph.*—This consists of a stout brass ring securely mounted to a handle of ebonite. A pencil of aniline is attached to the base of the handle. The pencil is controlled by a check spring, and when the latter is pressed, the pencil is released, which now jumps through the centre of the brass ring, marking the skin at the point where the shadow presented

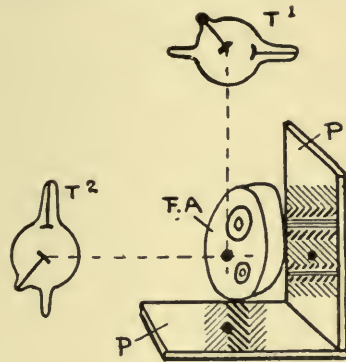

FIG. 172.—THE RIGHT-ANGLE METHOD OF LOCALIZATION.—P, photographic plate; T<sup>1</sup>, position of the tube; T<sup>2</sup>, position of the tube at right angles to the above; F.A, foreign body.

itself, as seen through the screen. In localizing a foreign body by this method, two of these instruments are simultaneously employed. The screen should be clamped to a frame, thus allowing the hands perfect freedom for manipulating the two instruments.

In examining the forearm for a foreign body, let us say a bullet, the part is brought between the screen and the tube, and the shadow revealed.

The first punctograph is then placed so that the opening of the brass ring encircles the shadow cast by the bullet. A second punctograph is applied similarly and directly opposite the first. The springs of both punctographs are now simultaneously released, and there result marks on the skin at opposite ends of a line. The arm is next rotated through the quadrant of a circle, the punctographs again being applied, and the springs released as in the beginning. It must thus become self-evident that four marks are now upon the arm, and by ordinary calculation and measurement the position of the bullet may be easily determined.

*Rémy's Method.*—The Rémy localizer, which is an extremely complicated device, and is with greatest difficulty elucidated by the use of diagrams, is thus briefly reviewed by A. W. Isenthal, F.R.P.S., and H. Snowden Ward, F.R.P.S., members of the Council of the Röntgen Society.<sup>1</sup>

“The Rémy localizer is a complicated apparatus, founded on the principle that it is necessary to ‘materialize’ those two X-rays which connect the anode with the foreign body and its screen shadow for two positions of the tube. By means of suitably placed sights and stops, one is enabled to bring the pointed rods (representing the X-rays) always back to their proper plane, so that the latter and the depth of the foreign object may be marked on the patient.”<sup>2</sup>

*Barrel's Method.*—Frank R. Barrel, M.A., B.Sc., of the University College, Bristol, England, thus tersely describes his localizer.

“My method requires no plumb-line, no threads, and no levelling. My ‘apparatus’ consists of two metal cylinders whose ends have been carefully turned perpendicular to their axis. A convenient size is four inches long and one inch in diameter. Place these cylinders upright on the plate during an exposure, and close to the limb holding the foreign body. The shadows thrown indicate the focus position of the tubes. To secure good long shadows, place the cylinders near the end of the plate furthest from the tube. After the first excitation shift the tube six or ten inches, the cylinders are also shifted towards the opposite end of the plate, and then the tube is again excited, giving rise to the second set of shadows from the foreign bodies and the cylinders. Lines are ruled along the edges of the two corresponding cylinder shadows for one tube position, and, producing them till they meet, we obtain that point on the

<sup>1</sup> Practical Radiography, Dawbarn and Ward, Publishers, 1901.

<sup>2</sup> For a comprehensive description of the apparatus and its mode of application, the reader is referred to Archives of the Röntgen Ray, August, 1900.

<sup>3</sup> Archives of the Röntgen Ray, May, 1900.



plate which was vertically beneath the tube focus during the corresponding exposure. Connecting the two points thus found with the corresponding shadows of the foreign body, we obtain two lines which intersect in a point which is vertically below the actual foreign body."

*Shenton's Method.*<sup>1</sup>—For such cases as needles or bullets in the hand, arm, or leg,—*i. e.*, in parts easily manipulated,—no special apparatus is required and no photographic process involved. Shenton describes his method as follows: "Hold the part, for example, a hand containing a needle, before the fluorescent screen. Start with the screen and the anode of the tube as nearly parallel as possible. When needle and bones are distinctly seen, sway the screen and hand from side to side, and note the change in relation of bones and needles. It is evident that the image of whichever is furthest from you and from the surface of the screen will move the faster. If the needle moves across the bones, its position is deeper than the bone; if bones move across needle, the latter's position must be between the surface of the screen and the bone. Should the needle appear to remain stationary, place a pointer against this image on the screen, and ascertain whether it moved a little or not at all. Verify these results by reversing the hand and repeating the manœuvres. A little practice enables one to give as near an estimate of the needle's real depth as any surgeon could require, and such suggestions as 'just beneath the palm,' 'midway between bones and skin,' 'lower end between the bones,' 'upper one-eighth of an inch between the skin of the back of the hand,' are, in my experience, sufficient for any operator. I doubt if a calculation in millimetres would be of more use. The body is an awkward thing to apply the millimetre scale to, and a little pressure on the skin, or a little swelling beneath it, will overthrow such minute calculations. The needle's depth being ascertained, it only remains to find its position in the horizontal planes, a task which presents few difficulties.

"When found, this position should be marked upon the skin. The advantages of this method are its rapidity of performance, the process taking but a few seconds, and the economy of material, both photographic and electrical. For localization in other parts of the body, and for photographically recording results, I have constructed an instrument which in principle is the same as the method just described, save that the tube is swayed, while the part viewed is held in position by bands and tension springs. The tube is moved by the observer from his side of the screen, the distance it travels being regulated by sliding steps. A fine vertical wire is stretched in the centre of, and in contact with, the screen. The image of the foreign body is to correspond with this line when the tube is in the mid-position. Upon moving the tube from the extreme right to the extreme left, the image of the foreign body on the screen is

<sup>1</sup> Archives of the Röntgen Ray, August, 1899.



seen to pass from left to right. Its relative rate of travelling, compared with the same portion of bone, is noted as before. For accurate measurements the true position assumed by the foreign body is marked by pencil on a celluloid film in contact with the screen. This measurement being secured, the distance the tube travels, and the distance from the mid-point of the line adjoining the two extreme positions of the tube, must be ascertained. A simple rule of three will now give the distance of the object sought from the screen."

*Harrison's Method.*<sup>1</sup>—"A seven-inch square is drawn on a board and its centre is accurately marked; at the ends of a line drawn through the centre, perpendicular to two of the sides, two upright rods are fixed (for convenience of carriage, these can be made to take in and out); at a height of seven inches on each of these pillars, a hook or loop is placed. Take the case of a needle in the hand. A double photograph of the needle and hand is taken with the light alternately right and left. A tracing of this photograph is then taken on the sensitive side, marking distinctly on the ends of the needle. The tracing is then placed so that its centre coincides with the centre of the square. Pins are then stuck, slantingly through the tracing, into the board at the ends of the needle. Cross threads are carried from the pins to the loops and kept stretched by small weights. Where these threads intersect will show the position of the needle relatively to the sensitive plate, which is represented by the tracing."

*Double Focus Tube Localization.*—This method was devised by Leonard<sup>2</sup> and is as follows: The technic required for triangulation methods prevented their general employment, and to simplify the application of the same principles, Leonard has had made a tube with two cathodes and two anodes, and hence two sources of rectilinear rays. This avoids errors when the position of the tube has to be changed or separate plates used, and it has made rapid accurate localization with the fluoroscope easy. The fluoroscopic method is as follows: Fix the screen in a perpendicular position. Place the tube horizontally so that the mid-point of the line connecting the two sources of rays is perpendicular to the plane of the screen, and at a known distance from the centre of the screen marked by an opaque cross. Place the limb before the screen so that the two shadows of the foreign body will fall equally distant on each side of the opaque spot and on the same line. Mark the spot in the patient's skin with nitrate of silver. By placing an opaque rod on the other side of the limb, where its shadows are equidistant from the opaque spot, the perpendicular is found and marked on that side. The foreign body, therefore, lies on this line at a distance from the opaque spot, that is determined by measuring the distance between the two shadows with calipers and

<sup>1</sup> British Medical Journal, April 2, 1898.

<sup>2</sup> American X-ray Jour., November, 1899.

plotting the shadowy paths by the graphic process, as when plates are employed, or by the cross-thread method.

*Stereoscopic Method.*—This method has already been discussed. I employ it, as it has yielded satisfactory results.

*Triangulation Method of Localizing Foreign Bodies with Measurement on a Graduated "T" Scale.* (Figs. 173, 174.)—In order to find the depth of the foreign body on the scale, bring the lower bar to the figure 10 on the upright. Connect a line at 20 on the uppermost horizontal bar, intersecting at 1.6 [DE] on the middle horizontal bar, which registers 4.53 cm. on the vertical bar, as shown in the following formula :

A = Position of the tube in the first exposure.

B = Position of the tube in the second exposure.

AB = Distance of the displacement.

C = Foreign body.

D = Shadow of the foreign body on the plate (first exposure).

E = Shadow of the foreign body on the plate (second exposure).

CA = 50 cm. — CD.

There are two triangles, = CAB and CDE.

DE = 1.6 cm., which is known.

AB = 20 cm.

$$\frac{CD}{2} = \frac{CA}{20} \quad 20 CD = 2(50 \text{ cm.} - CD)$$

$$20 CD = (100 \text{ cm.} - 2CD)$$

$$20 CD + 2 CD = 100 \text{ cm.}$$

$$22 CD = 100 \text{ cm.}$$

$$CD = \frac{100}{22} = 4.53, \text{ distance of the foreign body.}$$

*Orthodiagraphic Localizer of Grashey.*—Frequently it is found that foreign bodies imbedded in the tissues cannot be located with exactness, even when felt beneath the skin, or when Röntgen photographs are taken in different projections, because of the possibility of the foreign body varying its position to the bony parts from minute to minute. If the hand during the operation is not kept in exactly the same position as during the taking of the photograph, then the projection will be wrong. Recently Dr. R. Grashey, of Munich, devised an orthodiagraphic localizer. (Fig. 175.)

The operator sits before the table and is looking with one eye into the tube, and he sees an illuminated picture in the mirror of the cystoscope. With the other eye (the room not being darkened) he can look directly at the wound. The current is interrupted and closed by the help of a pedal. The tube is enclosed in a box, containing below a diaphragm, capable of effecting so small an opening that only a limited field of operation is illuminated. In this way, and by a plate of lead glass inserted in the front wall of the box, the operator is protected. The box is fixed on a support connected with one leg of the table, and revolves horizontally. Thus, it can be turned aside with a sterilized cloth, and when its use is

again required it can be turned back, and it will be at once over the former position, above the fluoroscope. The forearms of the operator rest comfortably on movable supports.

The illustration (Fig. 176) shows the path of the rays emanating from the anode of the tube R, that is in the box BK. Through the opening B, in the diaphragm, we see the body K, containing the foreign body

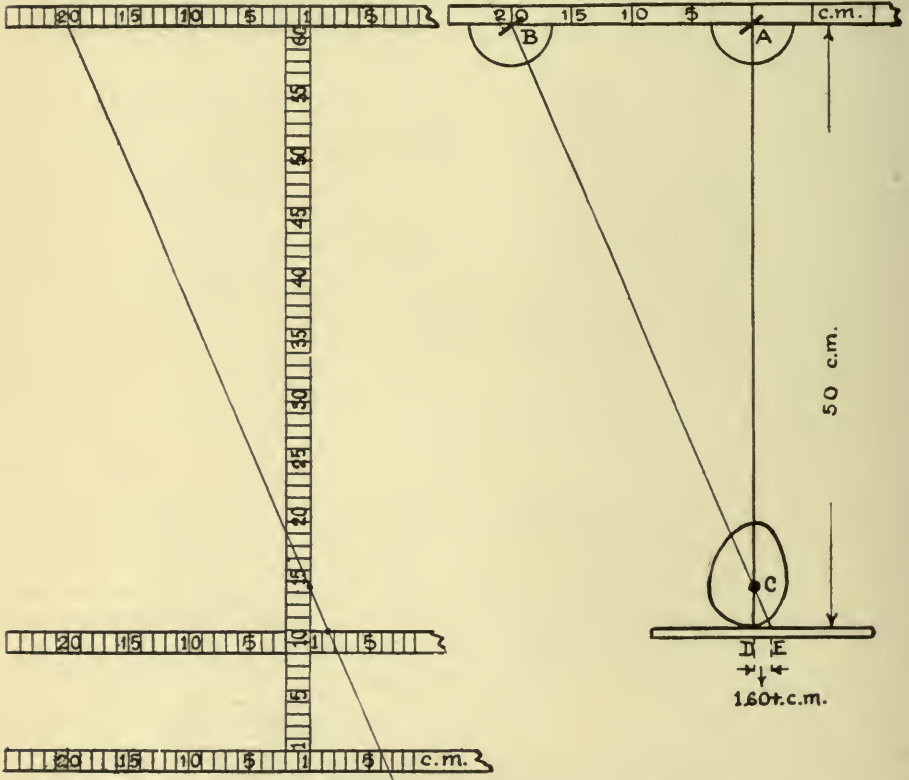

FIG. 173.—“T” scale used in triangulation method. FIG. 174.—Scheme of application of the “T” scale.

F. Upon the fluoroscope L, inserted on the table O, this picture is obliquely reflected by the mirror S, in the dark chamber D, into the telescopic tube T. In that case the anode focus and the centre of the fluoroscope M, marked by a little shot pasted on it, lie vertically one below the other. Thus it becomes easy to adjust any other body orthodiagraphically in line with the normal ray, as, for instance, the foreign body F contained in the hand K. If you move the point of a knife into the illuminated picture until its shadow covers that of the shot and also the foreign body that has previously been adjusted, then the point of the blade must be exactly above that of the foreign body.



For the determination of the location of a foreign body, whether in the eyeball or orbital cavity, take two separate skiagraphs, with the

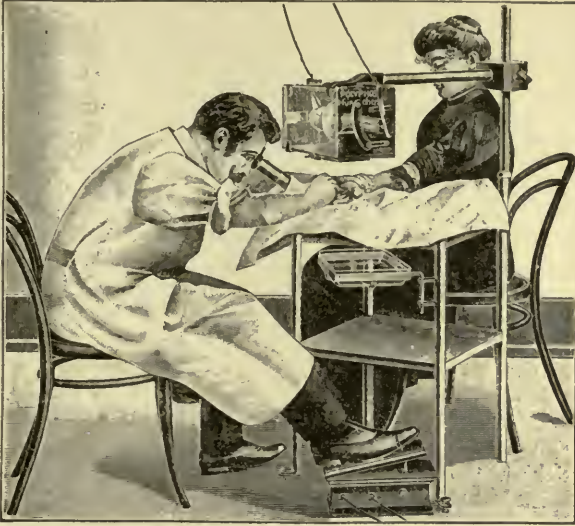

FIG. 175.—Orthodiagraphic localizer of Grashey.

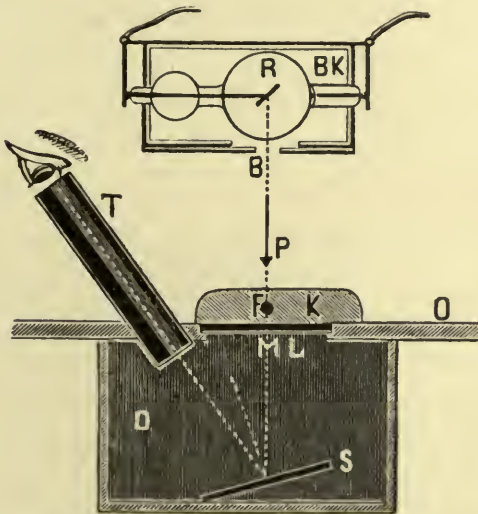

FIG. 176.—Diagrammatic view of the same.

tube-holder and plate in the same position in both instances ; or during half the exposure the patient rolls the eyeball ; if the shadow of the foreign body appears double, the offending substance is in the eyeball ; if in the orbital cavity, the shadow will be single.



## CHAPTER IV

### APPLICATION OF THE X-RAYS IN DISEASES OF THE THORACIC ORGANS.

THIS is subdivided into the *respiratory* and *circulatory* systems.

The value of the X-ray as a diagnostic agent in thoracic examinations has been and is being constantly demonstrated. The thorax and its contained viscera are easy of examination both by the fluoroscope and skiagram, largely due to the circumstance that the lungs are transparent to the rays. By a fluoroscopic examination we observe the excursions of the diaphragm, the expansion and retraction of the lungs and ribs, the different phases of the cardiac cycle, and the pulsations of the aorta.

The fluoroscopic interpretation is not the work of the novice. The beginner should first study the thoracic viscera fluoroscopically upon thin subjects and children, so as to accustom himself to the appearances presented normally.

The two methods of examination are with the fluoroscope and the skiagram. The advantages of the fluoroscope are these; it is inexpensive, easy of application, the part may be viewed from any direction, the intensity of the rays can be altered, the position of the patient, tube, and fluoroscope can be changed, movements of the thorax and its contained viscera can be studied and tracings made of their shape, size, and position. The disadvantages are the liabilities to burns, the lack of differentiation of the tissues of slightly varying densities, and the fact that the image is only transient.

#### I. Fluoroscopic Examinations.

*Anterior and Posterior Views.*—The screen, in an anterior view of the chest, shows a dark zone extending from the base of the neck to the diaphragm, a little to each side of the median line of the body; this is the shadow cast by the dorsal vertebræ, sternum, and heart. On both sides of this dark zone are the much lighter shadows produced by the lungs; traversing the lung shadows, on both sides from the shadow cast by the spine, are successive darker bands, the ribs. The heart's pulsations, its position, shape, and size can all be viewed by careful screen examinations. The ventricular chambers always present a dark shadow, the right auricle giving usually a lighter shadow than the left. Above the shadow of the ventricles and slightly to the left is the shadow of the pulmonary artery. In the first left intercostal space may be seen a part of the arch of the aorta. The shadow of the heart's apex will be observed to blend with the shadow of the diaphragm. The border of the pulsating

heart presents a slightly lighter shadow than its interior. The cardiac outline is best viewed through the anterior thoracic wall. A posterior view of the heart is less distinct, because of the intervening spine and lungs and of its anterior position in the chest cavity.

In a posterior view, a dark shadow corresponding to the left side of the heart is seen to the left of the spine, and a smaller and slightly less distinct but denser shadow of the right auricle is seen to the right of that produced by the spine. The organs of the thorax, represented on the screen, may be easily recorded in the following manner: The operator should employ a screen of sufficiently large dimensions to cover the entire chest, and upon whose dorsal aspect has been placed a sheet of white linen writing paper. In order to maintain a constantly steady position of the screen for a uniform and correct tracing, the patient should be seated comfortably, so that he may not move. The screen should be supported by a movable frame fastened to the arm, coming from a metallic upright free from all undue vibrations, as otherwise the examination will prove unsatisfactory. The screen having been placed either in front or in back of the patient's thorax (leaving 1 inch (2.5 cm.) space between the screen and chest), we are ready to trace on the paper the image cast on the screen by the use of an opaque pencil, preferably one that is indelible. I believe, however, that the orthodiagraph is always more desirable.

*Lateral and Oblique Views.*—In the lateral view, especially when seen from the patient's left side, the operator observes the heart in contact with the anterior chest wall, also the profile view of the heart, the aorta arching backward to approach the vertebral column, and an unobstructed interval between the posterior part of the heart and the spine.

The oblique view, which can be antero-lateral or postero-lateral, right or left, is taken with the fluoroscope at an angle of about  $45^{\circ}$  to the vertical axis of the body. This view is of value in an obscure diagnosis, in furnishing additional and often confirmatory data.

*Examination of the Lungs.*—The image of a normal lung, on a fluorescent screen or fluoroscope, is bright, the rays penetrating with less resistance the spongy tissue than ordinary dense tissue. This brightness of the screen differs in degree during the various stages of respiration. When the lungs are inflated to their fullest extent, there is represented on the screen a uniform bright light shadow. At the end of the fullest expiration the above degree of brightness has considerably diminished, as the lung tissue has become more compact. Between these two extremes there is a medium degree of brightness, obtained when respiration has temporarily been halted midway between inspiration and expiration.

As we would also naturally expect, in children and in thin adults the lungs appear brighter on the screen than in muscular or corpulent individuals. In the latter class of cases, as more tissue must necessarily be traversed by the rays, there is more chance for their absorption, hence the giving of more "shadow."

In examining a lung from below upward, the brightness of the shadow very slightly increases as we approach the apex. Usually the right lung presents a slightly lessened degree of shadow brightness as compared with the left. The shadow of the right apex in normal cases is always darker than the left. No satisfactory explanation has ever been given concerning this difference. Some authorities maintain that it is due to a slight hypertrophy of the muscle tissue of the right side of the chest. It is more marked in right-handed people, and we might naturally infer that the opposite would be true in left-handed people, although observations on such subjects have also proved the contrary to be the case.

*Normal Heart and Diaphragm.*—Dr. F. H. Williams<sup>1</sup> states that the radiosopic appearances of the normal heart and diaphragm as seen by a screen examination in the anterior view are the following :

“In health the diaphragm moves as follows: Quiet breathing, one-half inch (1.3 cm.); at full inspiration  $2\frac{1}{2}$  to 3 inches (6.5–7.5 cm.), and slightly more on the right than on the left side. A part of the aorta in some patients may be observed in the first intercostal space; in the second intercostal space a portion of the pulmonary artery; the left border of the ventricle is chiefly seen during a full inspiration, when the apex and a portion of the lower border are also visible; the maximum pulsation is at a point corresponding to the cavity of the ventricle, about where its outline crosses the fourth rib; during full inspiration the heart moves downward to the sternum. To the right of the sternum the outline of the large vessels is seen and, less distinctly, the right auricle between the second and fourth ribs. The right auriculo-ventricular line curves, with a slight indentation, from the second to the sixth ribs inclusive. During the momentary elevation of the diaphragm this line is pushed upward and outward. During a forced depression of the diaphragm it elongates and is carried downward and inward toward the sternum. Under ordinary conditions we find the lowermost portion of the heart's shadow fusing with that of the liver and the diaphragm.”

Dr. Albert Abrams<sup>2</sup> says: “The average normal excursion of the diaphragm in quiet breathing is five-eighths of an inch or  $1\frac{1}{2}$  cm.; between full inspiration and expiration, on the right side,  $2\frac{3}{8}$  inches or (about) 6.7 cm.; left side,  $2\frac{5}{8}$  inches or 7 cm.

“In long-chested persons diaphragmatic excursions are greater than in short persons with deep chests.”

*Measurement of the Diaphragmatic Incursion.*—Dr. H. Guilleminot<sup>3</sup> says: “On account of the slope of the diaphragm backward and downward, the highest point of the diaphragmatic arch is nearer the anterior than the posterior surface of the body. Moreover, the point of contact

<sup>1</sup>The Röntgen Rays in Medicine and Surgery.

<sup>2</sup>Journal of the American Medical Association, May 3, 1902.

<sup>3</sup>Archives of the Röntgen Ray, January, 1906.



of the tangent ray is displaced with the movement of the diaphragm, and this displacement varies with the subject and with the distance of the anti-cathode. All these cases of error are avoided by the use of orthodiascopy." He, in collaboration with M. Vannier, obtained a tabulation of 23 cases, comprising normal lungs and tuberculous lungs in every stage. From their observations they arrived at the following conclusions :

1. "On the right side the mean position of the diaphragmatic curve is 16.5 cm. below the suprasternal line, and on the left side it is 18.5 cm. below that line.

2. "The normal amplitude of the diaphragmatic incursion is from 16 to 18 mm. It is approximately equal on the two sides.

3. "Any variation in the amount of the incursion on the right and left sides is a pathological symptom, and in most cases has a serious clinical significance.

"The ratio between the amplitude of the diaphragmatic incursion and the costal angle depends greatly on the type of respiration, whether costal or abnormal.

"The inequality of the incursion of the diaphragm on the right and left sides is an important aid to diagnosis."

*The Measurement of the Costal Angle.*—Guilleminot has shown the possibility of radiographing the thorax in inspiration or in expiration. This may be accomplished by dissociating the phases of inspiration and of expiration by means of an automatic interrupter.<sup>1</sup> By this means one can obtain a cinemato-radiograph of the respiration. On these radiographs one may measure the obliquity of the ribs between two points on the upper margin of the rib at a distance of  $1\frac{3}{4}$  and  $2\frac{1}{2}$  inches (4 and 8 cm.), respectively, from the median line. If we now take any horizontal line and measure the vertical distances of these two points, the difference of the two ordinates will give us the obliquity of the rib for a distance of 4 cm., and this divided by 4 will give us the obliquity per centimetre. This is the cotangent of the angle with the vertical, made by a line passing through the given points.

"By this means it is easy to determine the costal angles of inspiration and of expiration. Their difference is the functional costal angle, which may vary from  $3^{\circ}$  to  $5^{\circ}$ .

"The orthodiascopic procedure is much more simple.

"With practice one is able to distinguish the projection of the upper border of a rib at its position of maximum elevation and depression while the patient breathes rather deeply.

"In each case it is important to note accurately the physiological type of the respiration, which may vary in all possible degrees between the abdominal and the superior costal type. For this purpose the

<sup>1</sup> Comptes-rend. Acad. Science, June 12, 1899.



tracing of the costal range should be accompanied by a tracing of the diaphragmatic incursion.

“If we take the means of these measurements, we obtain the following results :

$$\begin{array}{l} \text{Left} \left\{ \begin{array}{l} \text{Inspiration, } 77\frac{1}{4}^{\circ} \\ \text{Expiration, } 72\frac{1}{4}^{\circ} \end{array} \right\} \text{Mean position, } 74\frac{3}{8}^{\circ} \\ \text{Right} \left\{ \begin{array}{l} \text{Inspiration, } 76\frac{1}{4}^{\circ} \\ \text{Expiration, } 73^{\circ} \end{array} \right\} \text{Mean position, } 74\frac{3}{8}^{\circ} \end{array}$$

“In these observations the mean angle is the angle which the rib makes with the vertical when it is in a position midway between inspiration and expiration.

“The absolute coincidence of the mean angles on the right and left sides is certainly accidental, there being considerable divergence in certain instances.

“The mean costal angle may therefore be said to be approximately equal on the two sides, and to be about  $74^{\circ}$  to  $75^{\circ}$ .

$$\begin{array}{l} \text{Inspiration} \left\{ \begin{array}{l} \text{Left, } 78.6^{\circ} \\ \text{Right, } 77.8^{\circ} \end{array} \right\} \text{Mean, } 78.2^{\circ} \\ \text{Expiration} \left\{ \begin{array}{l} \text{Left, } 72.7^{\circ} \\ \text{Right, } 72.9^{\circ} \end{array} \right\} \text{Mean, } 72.8^{\circ} \end{array} \left. \vphantom{\begin{array}{l} \text{Inspiration} \\ \text{Expiration} \end{array}} \right\} \text{Difference} = 5.4^{\circ}$$

“The functional costal angle, therefore, in healthy subjects is equal on the right and left sides, and usually varies between  $5^{\circ}$  and  $6^{\circ}$ .”

*Causes of the Restriction of the Diaphragmatic Wave.*—Albert Abrams<sup>1</sup> says, in this connection: “The restricted diaphragmatic movements must be regarded as very suspicious of phthisis. This sign, first referred to by Williams, of Boston, has had no theory advanced to explain its existence. I will briefly summarize my investigations which gave birth to the theory that an emphysematous condition of the lungs exists in phthisis. Rokitsansky and Brehmer noted that lungs too voluminous coupled with a small heart characterized the phthisical habitus. If the physician were to depend on percussion dulness as an evidence of early phthisis, the affection would never be recognized; lung resonance, not dulness, is the early physical sign of phthisis. The rays are invaluable in the recognition of emphysema; in this condition, the lungs seem too large for the chest, the diaphragm is low and its excursions restricted.”

*Diseases of the Diaphragm.*—“In *spasm*,” says Abrams, “diaphragmatic movements are practically suspended on the affected side.

<sup>1</sup>Journal of the American Medical Association, May 3, 1902.

Suddenly the diaphragm contracts and descends several inches below its normal descent. Singultus may accompany the descent, whilst cyanosis and dyspnoea become intense. In paralysis, movements of diaphragm on the affected side are suspended; during inspiration, the midriff rises. In diaphragmatic pleurisy, movements of the diaphragm are very much restricted or even suspended. The upper part of the lung is brighter than normal, owing to over-distention.

*“Average Normal Excursion of the Diaphragm.*—In quiet breathing,  $1\frac{1}{2}$  centimeters; between full inspiration and expiration, 6.7 cm. on the right side and about 7 cm. on the left side. In long-chested persons the diaphragmatic excursions are greater than in short persons with deep chest.

*“Width of the Normal Heart.*—With the screen about 75 cm. from the tube and with the target directed toward a point where the median line is crossed by the fourth rib, the right heart measures 3 cm. from the median line, and the left heart 8.5 cm. from the median line; a total of 11.5 cm.”

## II. Skiagraphic Examinations.

The lungs may be examined in two ways, fluoroscopically and skiagraphically. What is stated below regarding the methods of examination is equally true for both the normal and abnormal lung.

*Position of the Patient.*—Skiagrams of the lungs may be made with the patient either in the sitting, semi-recumbent, or dorsal decubitus posture. In my experience the latter has always proved to be the more satisfactory of the two. The patient is requested to remove all clothing covering the thorax, in some cases not even permitting the retention of a garment next to the skin.

When the dorsal decubitus position cannot be taken, the patient starting to cough, or if he is suffering from dyspnoea, he should be requested to resume the semi-recumbent posture, having the head-end of the table elevated to an angle of  $45^\circ$ , so as to insure greater comfort and also in a measure to remove the pressure exerted upon the diaphragm and the adjacent lungs. I always request the patient to elevate the arms and clasp the hands over the head, in order to raise the scapulæ and thus remove their shadows from the shadow of the thorax.

Place two superimposed sensitive plates, well protected by a thin layer of celluloid, under the patient's thorax. The size of the plates employed will depend upon the size of the patient's chest; the plate should be slightly larger than the chest itself so as to extend on both sides about two inches beyond its outer margins.

The tube should be placed with the target pointing directly toward the centre of the whole thorax and from 20 to 25 inches (50 to 63 cm.) distant from the plate, depending upon the thickness of the chest and the

penetrative power of the tube. The cathode stem of the tube should extend toward the foot end of the table, to prevent alarming the patient by the sparking that necessarily occurs in self-regulating tubes.

POSITIONS OF PATIENT	No. of Experiments	Wehnelt	Mechanical Vibration 590 p. m.	CROOKES TUBE											
				Current to Primary Coil during Exposure		Distance of Anode from Plate		Degree of Vacuum				Intensifying Screen		Time of Exposure: Seconds	Results
				Volts	Amperes	Cm.	Variety	High	Medium	Low	With	Without			
I. PRONE.....	1		With	60	3 to 5	60	Self-Regulating	H				With	Without	30 to 35	Good
II. DORSAL OR RECUMBENT.....	2		With	60	3 to 5	60	"	H				With		8 to 10	Good
III. SEMI-RECUMBENT.....	3	With		25 to 40	15 to 20	60	"	H					Without	2 to 4	Fair
IV. SITTING OR ERECT POSTURE...	4	With		25 to 40	15 to 20	60	"	H				With		2 to 2	Fair

*Time of Exposure.*—Exposure should be as rapid as possible, otherwise the incessant motions of the thoracic viscera will cause a blurred shadow. Formerly this obstacle was partially overcome by telling the patient to take a deep inspiration and to “hold” the breath. I then took a short exposure (5 or 10 seconds), repeating the process five or six times in one or two minutes. But this method has been greatly improved upon, by the instantaneous process. Radiographs of the thorax have been made by Von Ziemssen and Rieder in one second of time, by the application of the Rosenthal method.<sup>1</sup> Rosenthal employs a Volt-Ohm apparatus, with a 60 centimetre coil, an electrolytic interrupter, and a Volt-Ohm tube. The time of exposure is shortened by the use of two intensifying screens, one being placed with its coated side against the coated side of the film and the Schleussner film then laid between the intensifying screens, the coated sides of which are toward the photographic film. These are then enclosed in three light tight envelopes. The patient lies on his abdomen or back upon the photographic plate, or the

<sup>1</sup> Münchener medicinische Wochenschrift, 1899, No. 32.



plate is placed upon the particular part desired to be photographed, and the current is opened for a moment and as quickly closed. The plates are then removed and developed in the usual manner.<sup>1</sup>

### III. Clinical Applications.

#### A. DISEASES OF THE BRONCHI AND LUNGS.

The X-rays have proved themselves invaluable in diagnosing pulmonary affections and conditions, affording in many cases confirmatory evidence and guiding the practitioner in numerous incipient conditions into a correct understanding of the pathological changes present. Early in the progress of pulmonary diseases, where marked changes are not fully in evidence, the usual physical methods employed often fail to elicit the proper pathognomonic signs, and it is here that the X-rays serve as a most valuable adjunct.

*Bronchitis.*—Most cases of bronchitis fail to show the normal brightness of the lung, when free secretion is once established. The characteristic clouding is usually limited to the lower two-thirds of both lungs. In this affection the excursions of the diaphragm are usually unrestricted, except where the smaller bronchial tubes are obstructed by an exudate. If the patient is instructed to cough, the secreted material may be expectorated or else temporarily removed from the lower portion of the lung; thus permitting the excursions of the diaphragm to be more perfectly restored. In chronic bronchitis, with considerable coughing, there is likely to be some dilatation of the right ventricle. If the bronchitis is of tuberculous origin, small shadows of the involved areas are usually confined to the apical regions. In bronchitis associated with influenza, a few localized shadows may be discerned, which are really the complicating foci of a lobular pneumonia.

*Bronchiectasis.*—This condition in itself does not produce any shadows on the screen or skiagram, unless the adjacent lung tissue is consolidated or infiltrated with calcareous substances. When studying this condition, the patient should be examined in various positions and from all directions. The shadows of bronchiectatic areas are generally found in the middle and lower thirds of the lung, and are usually posterior. In uncomplicated cases of bronchiectasis there are no causes for restriction in

<sup>1</sup> In 1905, during the Röntgen Congress in Berlin, Drs. Rosenthal and Rieder, of Munich, exhibited skiagrams of thoraxes which were taken with an exposure of one-tenth ( $\frac{1}{10}$ ) of a second.

In 1901, Mr. Isenthal (Archives of the Röntgen Ray, vol. v., No. 5) exhibited in London instantaneous skiagrams; in 1904, Dr. Henry Hulst, of Grand Rapids, Mich., read a paper before the American Röntgen Ray Society in which he likewise showed instantaneous skiagrams of the thorax; in 1904 I experimented with different methods on the same patient at the Philadelphia Hospital, and arrived at the above conclusions. See tabulation, page 312. (Transactions of the American Röntgen Ray Society, 1904.)



the movements of the diaphragm. If, however, an emphysema be present, then the excursions will be restricted, and the midriff will be observed to occupy a lower position. As a result of a purely bronchiectatic condition, the heart very rarely changes its shape, size, or position. If such a cavity is healing, a considerable quantity of scar tissue is gradually developed, which, by contraction, may displace the heart from its normal position. In a complicating emphysema the heart is displaced by the latter and not by the bronchiectatic disease. If the chest is examined before the bronchiectatic cavity has been emptied by coughing (the best time for examination of this condition being after the patient has been resting in the recumbent position for several hours), a distinct shadow corresponding to the cavity is very easily seen, followed by a brighter appearance as soon as the contents have been evacuated.

D. B. King<sup>1</sup> furnishes notes on 20 cases studied by the Röntgen rays, in addition to the other usual methods of examination. In each instance the endeavor was made to detect the presence or absence of (1) dilated bronchi. In advanced cases where the bronchi were much dilated, as shown by the stethoscope or at autopsy, the Röntgen rays failed to reveal their presence. (2) In cases of saccular cavities. Here the rays failed to reveal such cavities, probably because of the associated fibrosis of the lung. (3) The condition of the lung tissue. Fibrosis of the lung was shown by increased intensity of the shadows. (4) The presence of foreign bodies. For the detection of foreign bodies in the bronchi, the rays are of undoubted value. (5) Study of the action of the diaphragm. This was found to be impaired or obscured, depending upon the degree of change in the lung. King states that the general value of Röntgen ray examination in cases of bronchiectasis is sufficient to warrant its employment on more than one occasion, though this may give no further information as to the real nature of the case than is furnished by ordinary clinical methods.

*Asthma.* — In asthma the lungs cast a brighter shadow than the normal, extending higher up and lower down in the thoracic cavity. The position of the diaphragm is observed to be low, and its movements much retarded. It is interesting to study a paroxysm of asthma while the rays are penetrating the thorax. Such a paroxysm can be provoked by injecting cold water into the nasal chambers or by packing the nostrils with cotton. During a paroxysm, the lungs look very similar to the condition seen in emphysema, differing however from the latter in that there is a complete fixation of the diaphragm; the disappearance of the paroxysms being evidenced by the restoration of the lungs to their natural shadow brightness. The heart occupies a lower position and moves less frequently during inspiration than it does

<sup>1</sup>The Practitioner, February, 1904.

normally; the right ventricle is much increased in size, and the outlines of the heart are unusually clear cut and sharp, owing to the brightness of the lungs during a paroxysm.

*Emphysema.*—In this affection the pulmonary area is increased, and when viewed with a screen it is much lighter than is the normal lung. This area of brightness reaches high above the clavicles, and at the same time it extends downward, depressing the diaphragm. It is said by some that the diaphragm presents two more or less distinct curves (one on each side), instead of one large curve as is seen normally.

During ordinary quiet breathing, the diaphragm appears to descend very low in the thorax, though in a forced expiration it ascends to a higher level. In pneumonia of one lung there is generally a compensatory emphysema of the other, the emphysematous lung appears much brighter on the screen than it does in health. The area of the heart when viewed with the screen is very nicely defined in emphysema. The dark shadow produced by the heart stands out boldly against the much lighter field produced by the emphysematous lung. The heart occupies a lower position in the chest and assumes a more vertical direction than when the lung is normal. In the severer type of emphysema the screen shows both the right auricle and the right ventricle to be much enlarged. If tuberculosis is a complication, the pulmonary brightness appears spotted by irregular darkened shadow areas, usually confined to one or the other apex and occasionally involving both.

*Broncho-Pneumonia.*—In broncho-pneumonia circumscribed shadows widely scattered throughout the lungs are observed on the screen, with an occasional coalescence of the circumscribed foci. Under such circumstances the shadows are usually limited to the middle and lower lobes and are seldom found in the apical regions. The diaphragm frequently occupies a very high position, especially during inspiration, with great restriction of diaphragmatic movements. If there are no complications, the heart does not change its position. Shadows are occasionally produced in certain portions by the collapse of the lung tissue; coughing and deep breathing cause their evanescence.

*Pulmonary Tuberculosis.*—The shadow on the screen of an early pulmonary tuberculous lesion is difficult of interpretation.

Two very important signs that may be elicited by the rays, are a slightly restricted diaphragmatic movement on the involved side (Williams' sign), and the hazy, darkened, and occasionally emphysematous appearance of the lungs. As restricted movements of the diaphragm frequently indicate an incipient tuberculosis, they should always be regarded with suspicion.

To determine the presence of Williams' sign, first view the excursions of the diaphragm during ordinary breathing, and mark the highest elevation on the lower chest by means of an indelible pencil. This tracing should be made on both sides of the chest wall. This quiet breathing



should be followed by a full, deep inspiration, and the lowest point to which the diaphragm descends should be noted in a similar manner, and likewise on both sides.

Two or three deep inspirations successively following one another may be necessary to bring out the lowest point to which the diaphragm descends. The patient next expires as deeply as possible, and the highest point attained by the diaphragm is traced in a similar manner. When the excursion from a deep expiration to a deep inspiration is diminished on one or the other side, there is also a diminished excursion of the diaphragm during ordinary breathing on the affected side. The fact that the diaphragm rises somewhat higher on the side of the lesion during a forced expiration, should not be overlooked. In advanced cases of tuberculosis the side of the diaphragm corresponding to the affected side always rises much higher than does the normal side, though at the same time the excursion up and down is continually diminished. If one lung is partially or wholly diseased, the diaphragmatic excursion on the sound side is slightly increased, as compared with the affected side. The higher position of the diaphragm taken in advanced cases, would seem to be due to a degeneration or shrinkage of the lung tissue on the diseased side; the excursions may also be diminished during respiration by adhesion between the lung and diaphragm, or by an increased quantity of air entering the organ, resulting from a parenchymatous destruction, etc. An exact study of the diaphragm's movements is perhaps most satisfactorily conducted by a careful fluoroscopic examination.

The hazy, darkened appearance of pulmonary lesions, especially of the incipient tuberculous stage, should always be studied from above downward, commencing at the apices. All hazy, darkened areas on the screen should be outlined on the skin by an indelible pencil or crayon.

These are usually brought out more distinctly after a full inspiration. In attempting to detect such a hazy area at the apex or in a lobe, the patient should be requested to droop the shoulder on the side under examination, so that the shadow produced by the clavicle may be lowered out of the field as much as possible. A better view of the affected field may be obtained by having the patient stoop forward, allowing the rays to enter the thorax at the mid-scapular region, placing the screen directly over the supraclavicular space. The examiner should compare the light produced by the two apices both during full inspiration and during deep expiration. The light coming from the tube should be so regulated, by increasing or decreasing the distance between the tube and patient, that the affected side is only faintly illuminated. When the two sides are now compared, the sound side appears slightly brighter than the other. The excitation of the tube may be controlled partly, by a speed regulator or by a rheostat, but these are seldom required.

When both apices are involved in a tuberculous process, usually one apex is more extensively affected than the other, *i. e.*, there is distinctly more haziness on the side most affected. A clouded appearance of both apices is indicative of an already advanced form of tuberculosis. In the early stages of this disease, an associated emphysematous condition of the lungs, occurring in the middle and lower thirds, may be demonstrated.

The value of the X-rays in incipient pulmonary tuberculosis may be well illustrated by the reports of the following cases in the service of Prof. James M. Anders, which were under my care for a skiagraphic examination.<sup>1</sup>

CASE I.—S. H., female, married, aged 28 years, cigar-maker, first applied at the out-patient clinic of the Medico-Chirurgical Hospital, Philadelphia, June 6, 1899, for treatment. A brother died of acute phthisis. The patient had had some of the diseases of childhood; but the remainder of her history was negative. Her illness began with paroxysmal pains in the præcordia, and this lasted for a considerable period. The day previous to her visit she had expectorated blood, which she stated was coughed up; the quantity of blood was small, bright red, and frothy. The abnormal physical signs were an impairment of the percussion-note and harsh breathing, with prolonged high-pitched expiration at the right apex, with absence of the vesicular quality, and prolonged high-pitched expirations at left apex; all signs, however, were less marked than at right apex. Microscopic examination of the sputum gave a negative result. Later an X-ray examination revealed an abnormal shadow or marked haziness at the apices of both lungs, but more marked at the right.

CASE II.—P. K., aged 29 years, cigar-maker, applied for treatment at the out-patient clinic of the Medico-Chirurgical Hospital, November 10, 1899. The family history is entirely negative as to pulmonary diseases. The patient suffered none of the diseases of childhood. He had had typhoid fever one and a half years previously, which confined him to bed for ten weeks. Since then he had been complaining of persistent gastric disturbance, evidenced by eructations of gas and dull pains in the epigastrium after meals; there had been some dyspnœa on exertion, and at intervals cardiac palpitation. A few days prior to his first visit, he began to expectorate bright-red blood. Subsequently there was neither cough nor expectoration. The amount of blood lost did not exceed half an ounce. An examination of the throat and larynx was negative, and the same was true of a physical examination of the thorax, although the chest was of the paralytic or phthisical type. After excluding all causes of hæmoptysis, except pulmonary tuberculosis, an X-ray picture was

<sup>1</sup>Journal of the American Medical Association, January 12, 1901, and reported by me to the American Congress of Tuberculosis, May 14, 1902.



made. This showed commencing consolidation over circumscribed areas on both sides just below the apices.

CASE III.—J. O., aged 14 years, errand boy, was admitted to the wards of the Medico-Chirurgical Hospital, November 13, 1899. Father died, in his fifty-second year, of heart and lung disease, the precise nature of which the patient does not know. One sister is in delicate health. The lad had had the usual diseases of childhood and a severe illness of unknown character a few years since; had always been in delicate health. The present illness began about four weeks before he came under my observation. The first symptoms complained of were malaise, headache, a slight cough in the evenings and mornings, more or less abdominal pains, associated with slight diarrhoea. The evening temperature on admission was on the average about 100° F., but abdominal pain, diarrhoea and cough had largely subsided. Physical examination showed a paralytic or phthisical thorax, without any other abnormal physical sign. After excluding typhoid fever, latent tuberculosis was suspected; tuberculin was injected, followed by a positive reaction. An X-ray examination was also made by Dr. Kassabian, and showed a slight haziness below the left clavicle. (See Figs. 177, 178.)

*Cavitation.*—As cavity formation begins in the centre of a consolidated mass, after it has slightly advanced we may observe a lighter field encircled by a darker shadow zone. If the outer margin of the cavitated mass has been infiltrated with inorganic salts, we may demonstrate on the screen a dark, narrow border-like shadow, encircling a larger light field. If the cavity is filled with exudative material, there will be no light reflex, presenting the appearance of a consolidated mass. This would also be true if the entrance to the cavity were located at the upper surface. In some instances this fluid can be readily removed by having the patient lie down and cough, when the light reflex may be noted to again return. A dilated bronchus, with exudative material and consolidated structure surrounding it, cannot be differentiated from a small cavity by means of the X-rays. Where the cavity is small and the wall thickened, little or no light reflex may be visible on either the screen or skiagram.

As the different pictures of pulmonary tuberculosis presented by the screen and skiagram bear a striking similarity to other lung affections, the employment of special methods for more accurately determining and differentiating the true condition would seem of first importance. Thus, Dally,<sup>1</sup> who has made a great many pulmonary examinations by means of the X-rays, states that the earliest indication of pulmonary tuberculosis is the unilateral limitation or loss of mobility of the diaphragm. Prior to any shadow production (the result of tuberculous involvement) the action of the diaphragm becomes gradually lessened on the affected

<sup>1</sup> Lancet, June 27, 1900.

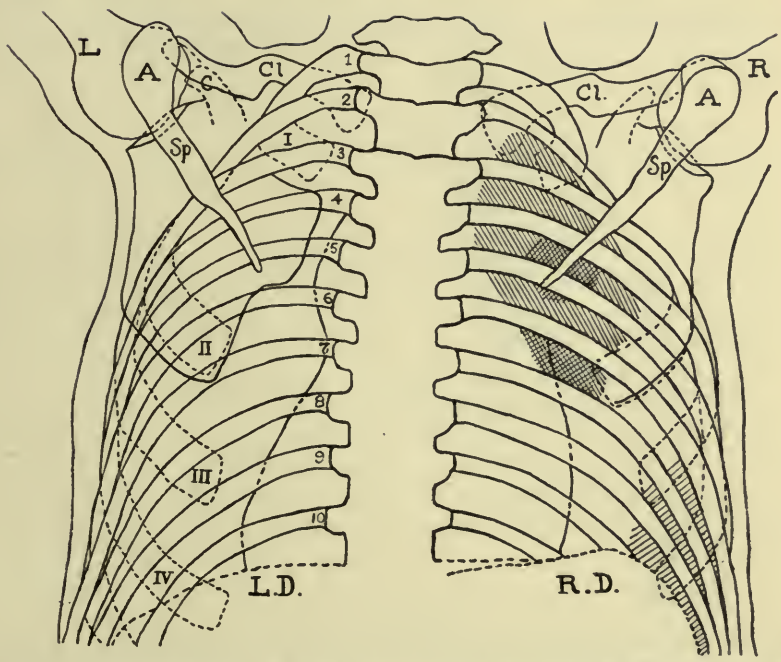

FIG. 177.—Tuberculosis of the right lung (posterior view), and a photographic tracing of the same. The skiagraph shows consolidation of the right apex and right base; heart is displaced toward the right. A, acromion process; Sp, spinous process of scapula; Cl, clavicle; C, coracoid process; 1, 2, 3, 4, 5, 6, 7, 8, 9, 10, ribs (posterior); I, II, III, IV, ribs (anterior).

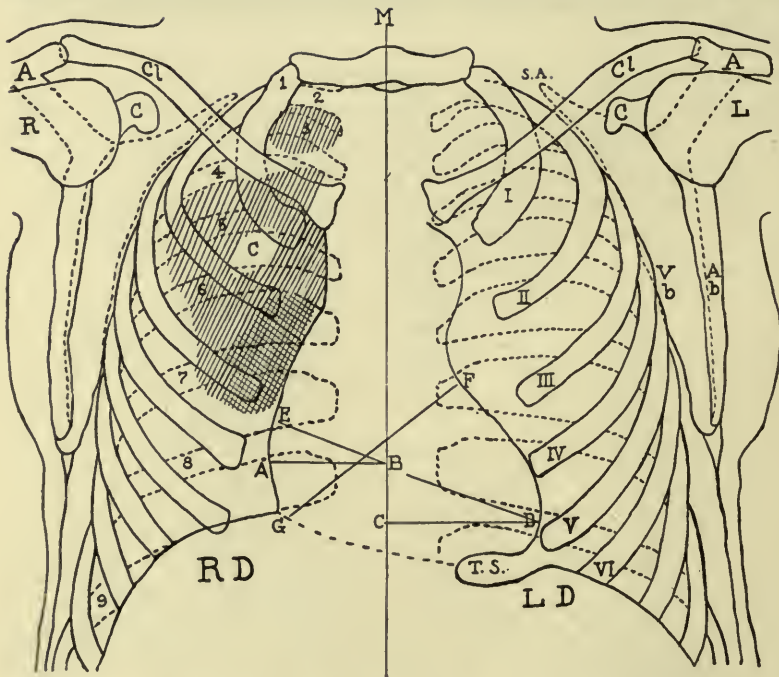

FIG. 178.—Tuberculosis of the right apex (anterior view). Plate placed in front of chest. The chest of the same patient as shown in Fig. 177. The lower cut is a photographic tracing of the above. Ab, axillary border of scapula; Vb, vertebral border; S.A., superior angle; RD, right side of the diaphragm; LD, left side; T.S., triangular space, best seen with the screen against the chest, between the heart and the diaphragm (for the diameters of the heart, see page 330); C, cavity, which was not visible on the posterior view.



side. After the tuberculous process has advanced to the point of producing distinct cloudy shadows within normal lung shadows, the limitation of diaphragmatic movements usually becomes more and more evident; it may, however, decrease.

Cases are reported where marked limitation in the mobility of the diaphragm was present when only the apical region of the lung had been involved. He further states that the typical shadow of an early pulmonary tuberculous process is irregularly mottled, and that such an appearance may be simulated by a new growth, but the latter can readily be differentiated by the characteristic distribution of the shadow and by the peculiar physical signs. A consolidated area produces a shadow of moderate density, and this in itself is increased when the adjacent lung tissue is hyperæmic. He believes that a caseating process throws a still deeper and darker shadow. The appearance of cavities will vary according to the size, position, and whether filled or empty. Those empty and located at the apical region of the lung are usually transradiant; when filled with pus they may remain unnoticed. In brief, Dally believes that the unilateral limitation of diaphragmatic movement as seen by the fluoroscope is very often the earliest sign of a beginning pulmonary tuberculosis, and that only by the X-rays can pulmonary tuberculosis be diagnosed at an earlier stage than by the other means at the disposal of the practitioner.

Dr. Dally<sup>1</sup> classifies the quality of the shadow, with the percussion note manifested, as follows:

RÖNTGEN RAYS....	{	Brightness	=	Hyper-resonance	}	..PERCUSSION NOTE
		Transradiancy	=	Normal resonance		
		Faint shadow	=	Impaired resonance		
		Dense shadow	=	Dulness		
		Opacity	=	Absolute dulness		

Vieruzhsky, of the Nikolas Military Hospital, which is devoted especially to the treatment of tuberculosis, reports elaborately on the results obtained by the various methods of diagnosing tuberculosis.<sup>2</sup> He is enthusiastic at the results obtained from the use of the Röntgen rays in the diagnosis of the early stages of pulmonary tuberculosis. The use of the spirometer as an agent assisting in the diagnosis of this disease has not been satisfactory, the figures obtained in the measurement of the respiratory capacity of the lungs being uncertain and variable. He is well able to realize the deficiencies and limitations of the X-rays, but he asserts that skiagraphy offers a means of controlling and confirming the data of physical examinations.

*Acute Military Tuberculosis.*—This disease is difficult to diagnose clinically; and it is often overlooked by reason of the frequent absence of physical signs. The only means then left to the practitioner is by an

<sup>1</sup> Lancet, June 27, 1903.

<sup>2</sup> Roussky Vrach, April 26, 1903.



X-ray examination. In this disease the screen or skiagram presents very small darkened shadows, scattered throughout the lung.

*Pneumonia.*—The various stages of croupous pneumonia may be studied both with the screen and the skiagram. A central pneumonia which resists detection by the ordinary physical signs may be detected by the aid of the X-rays.

In the stage of congestion there is a uniform dark shadow cast on the fluorescent screen; the result of an increased quantity of blood in the affected part of the lung.

The stage of consolidation presents a still darker shadow, due to the increased density.

A centralized consolidation, not demonstrable clinically, throws a shadow on the screen, equally as well as a simple superficial lesion. In croupous pneumonia I have observed the middle lobe of the right lung to be the one most frequently involved. In this condition the excursions of the diaphragm are almost entirely obliterated. In the majority of instances the right side of the heart is enlarged and displaced to a greater or less extent. In some cases involvement is so extensive as to shroud the shadow ordinarily cast by the heart. That the cardiac displacement is due to the pressure of the dense lung, is demonstrable by the rays.

The stage of resolution is characterized by the lung tissue returning to its former normal structure, and when the shadow cast by the previously affected side is similar to that cast by the non-involved side, we speak of the organ as having again returned to the normal. The shadow of the previously affected area may persist until complete resolution has occurred, while continued persistence of a shadow in this region may indicate a thickened pleura.

A croupous pneumonia must be diagnosticated from pleurisy with effusion, from an acute bronchitis, and from pulmonary tuberculosis. The physical signs and clinical symptoms are frequently ill-defined in a pleurisy with effusion, so that it may be confounded with a pneumonia. In a non-encysted pleurisy with effusion, a dark shadow is thrown on the screen, which changes its position with the change of position of the patient. In a pneumonia there is no change in the shadow demonstrable when moving the patient. In pleurisy with effusion there is a much greater displacement of the heart than in an uncomplicated pneumonia.

Lately I examined a child for an unresolved pneumonia, affecting the middle lobe of the right lung. The consolidated spots closely simulated a dry pleurisy; but the latter casts an irregular longitudinal shadow, the former circular.

*Atelectasis.*—The shadows produced correspond to the areas involved in the collapse of the lung. If collapse is extensive, the shadows cast on the screen are corresponding in size. The excursions of the diaphragm are not, as a rule, restricted, and its position is normal. The heart does not change in its normal shape, size, and position in a beginning

atelectasis, though in advanced cases with fibrous tissue formation, followed by contraction of large parts of lung tissue, the heart may finally be more or less displaced. The shadows may disappear if the patient is instructed to breathe as forcibly as he can.

*Abscess and Gangrene.*—The exact location of either an abscess or gangrene is indicated by a dark shadow. These conditions are usually found to involve the lower part of the middle lobe or upper part of the lower lobe. As an abscess cavity usually opens internally, and the foul material is expectorated, the shadows disappear immediately after the cavity is emptied. The excursions of the diaphragm are usually more or less restricted, depending upon the size and location of the abscess. The position of the diaphragm is normal, and the heart does not change in position. If the shadows are multiple, they indicate multiple abscesses.

## B. DISEASES OF THE PLEURA.

*Pleurisy with Effusion.*—In pleurisy with effusion the diaphragm is only slightly, if at all, observed on the screen, depending upon the amount of the effusion present. Because of the pressure exerted by the fluid upon the adjacent lung tissue, the latter is more dense; hence the fluid throws a dark shadow upon the fluorescent screen, usually denser than that cast in any other thoracic condition.

On changing the position of the patient, the change of level is easily discerned by the aid of the fluorescent screen. The upper level of the fluid is better seen in the sitting than in the recumbent posture. With an abundant quantity of fluid within the pleural sac, the heart as a rule suffers considerable displacement, and far greater when the pleural effusion is confined to the left side than when it exists on the right side only.

The shadows of the ribs are usually very faintly shown on the affected side above the pleural effusion. As a rule, the heart is displaced prior to a downward displacement of the diaphragm. The excursions of the diaphragm are usually much restricted, especially when the effusion is abundant. Small effusions are often to be detected in the small angular spaces on each side between the diaphragm and chest wall. Pleural thickenings are not infrequently mistaken for small effusions. Pleural adhesions are indicated by limited excursions of the diaphragm. After aspiration a clearing up of the previous darkened shadow may be noted, the ribs may again be detected, the heart will immediately resume its normal position, and the excursions of the diaphragm are again increased.

Even though there is only a small quantity of effusion in the pleural sac, the lung tissue above the fluid level toward the apex presents a darker appearance than the same field of the normal side, this being in all probability due to a compression of the lung on the affected side. If

the right pleural sac is completely filled by fluid, this shadow fuses with that of the heart (in the median line or slightly to the right), liver, and diaphragm; hence, all the brightness of the right side is totally lost.

Prof. Ch. Boucard<sup>1</sup> was the first investigator to publish observations made with the screen in pleural effusions. He demonstrated that the X-rays do not pass through the effusion. He also showed that the shadow indicated the upper level of the fluid, as confirmed by the ordinary methods of physical diagnosis.

Dally,<sup>2</sup> from his radioscopic study of pleurisy with effusion, concludes that the level of the fluid changes with the position of the patient unless the quantity of fluid is great and is encysted by adhesions. A purulent effusion yields a shadow of greater density than a sero-fibrinous effusion. The shadow is homogeneous, and in the case of the serous effusion the shadow gradually increases in density from above downward. However far the heart is displaced to the right, in most cases little alteration takes place in the position of the apex relatively to the base. Other conditions being equal, the heart is displaced more when the effusion is left sided. A somewhat triangular shadow, not normally visible, above and continuous with the shadow of the heart and pericardium is cast by the mediastinum, which is displaced by the lateral pressure towards the healthy side of the thorax.

*Empyema.*—In empyema the displacement of the heart and liver is greater than with the same quantity of serous exudate. In pulsating pleurisy, the heart movements transmitted to the fluid may be seen as diffuse undulations, if the patient remains motionless for the time being. According to my experience, the shadow of an empyema on a fluorescent screen frequently seems to be a shade darker than that produced in an ordinary pleurisy with effusion. This may be accounted for by the fact that in an empyema there is usually associated a slight œdema of the chest wall over the seat of the exudate. When there is no such œdematous condition coexisting with an empyema, the shadow cast by the retained pus is of the same density as that of an ordinary pleural effusion. An interlobar empyema (a condition very difficult to diagnose by ordinary means) casts a shadow of the encysted pus on the screen; the surrounding lung, above and below, presents the normal brightness, provided there is little or no compression of the adjacent pulmonary tissue by the enclosed fluid, the movements of the diaphragm are not restricted, nor is the heart displaced from its normal position. Diaphragmatic pleurisy is indicative of an involvement of the pleura in relation to the diaphragm. There is usually a small quantity of exudate present, which can only be revealed with difficulty, by a careful screen examination. Of several cases of this condition that came to my

<sup>1</sup> Archives d'Élect. Médicale, July 13, 1896.

<sup>2</sup> Lancet, February 27, 1904.



attention, four showed very distinct shadows on the screen. Hemorrhagic pleurisy cannot easily be differentiated from other types of pleurisy by the X-rays.

A pleurisy of the sac with effusion may be complicated with an empyema. An empyematous condition of the left pleura would make its appearance on the opposite side. In case a pleurisy has been diagnosed, complicated by unusual dyspnoea, the examiner should then look for an associated empyema of the opposite lung.

*Pneumothorax.* — The affected side presents a very bright area and of rather large size. The lung tissue is retracted, and the diaphragm occupies a lower position than normal; its movements are greatly restricted, and occasionally no movements are at all recognizable. The cardiac outlines are clearly defined, with a displacement toward the unaffected side.

*Hydro-pneumothorax and Pyo-pneumothorax.*—In studying the affected side of the chest, with the patient in the sitting posture, the fluorescent screen shows a very dark area below and a lighter one above. It is best demonstrated with the tube behind the patient, the target facing the third intercostal space (fourth rib). With the change of position of the patient, the fluid may be noticed to alter its level; the fluid also changes its level during respiration, rising during a deep inspiration and falling during a deep expiration.

The excursions of the diaphragm are usually wholly obliterated, while it also occupies a very low position, and the heart is displaced toward the unaffected side. The pulsations disturb the upper level of the fluid area, a condition which may be readily studied by the fluorescent screen. If the lung is examined in the median line and above the fluid area, it usually appears slightly darker as a result of compression. The degree of displacement of the heart and liver depends upon the amount of air and fluid retained in the pleural cavity. An apical tuberculosis of the affected side can very readily be diagnosed, as the surrounding field usually appears intensely bright.

*Subphrenic Abscess.*—A subphrenic abscess gives a dark shadow in the lower part of the thorax, and above it there is a lighter shadow due to the presence of air, and, surmounting this, there will be a shaded field caused by the compressed lung. The diaphragm occupies a slightly higher position with a total abolition of its movements. The heart is displaced toward the unaffected side, though this displacement is not so extensive as in hydro-pneumothorax. The upper level of the dark area changes with the change of position of the patient, and splashing of the enclosed fluid may be recognized when the patient is grasped by the shoulders and shaken.

*Tumors of the Thorax.*—Intrathoracic growths cast shadows upon the fluorescent screen. These masses are generally circumscribed, and are, as a rule, located in the upper part of the chest. Care must be exercised to



differentiate these growths from thoracic aneurism; in the former the tumor pulsates with an up and down movement, in the latter, the movement is expansile.

If the tumor is not too large there is no restriction in the excursions of the diaphragm. The heart is generally slightly displaced. Small calcified lymphatic and bronchial glands are often noticeable.

*Enlarged Glands.*—Any enlargement of the thoracic, mediastinal, or bronchial glands is easily shown on the fluorescent screen or skiagraph. As the bronchial glands are usually first involved in tuberculous conditions of the lungs, a few authorities have successfully demonstrated a slight enlargement of the glands in the incipient stage. Any glandular enlargement should be viewed suspiciously as the beginning of an adjacent tuberculous involvement. This condition is best viewed on the screen by having the rays traverse the body diagonally.

#### IV. Application of the X-rays to the Circulatory System.

In fluoroscopying the normal heart in the anterior view, we observe the shadow of the heart and aorta. These shadows are due to the opacity of the contained blood and to the superimposed shadows of the vertebræ and sternum. The posterior view shows the same structures in their posterior aspects. The anterior view, however, is preferable, as the heart being nearer the chest wall allows of a clearer shadow on the fluoroscope. Fluoroscopy is preferable to skiagraphy in the study of the circulatory system, as with it we can observe the cardiac cycle, the aorta and the movements of the diaphragm, from various positions.

##### A. FLUOROSCOPIC EXAMINATION OF THE NORMAL HEART.

The heart may be examined with the patient in the sitting, standing, or recumbent posture. The heart when viewed by the screen occupies a characteristic position in the thorax, when the patient is seated on a stool. During expiration it rests on the diaphragm, its long axis forming an acute angle with the imaginary median line of the thoracic cavity. In inspiration the heart moves downward and toward the median line; the right border of this organ is plainly seen to the right of the sternum, the larger or left part of the heart is seen to the left of the sternum,—*i. e.*, the long axis of the heart forms with the median line during expiration a less acute angle than during an inspiratory effort. During inspiration the transverse diameter of the heart is slightly decreased in length, at the same time the number of pulsations are lessened. In expiration, after the diaphragm has discontinued tugging on the heart, the transverse diameter is again increased, as is also the amplitude of its pulsations. The general contour of the organ can be more easily seen during inspiratory periods than in the expiratory, because the lungs, being filled to their capacity, are more transparent to the rays, thus offering a more striking

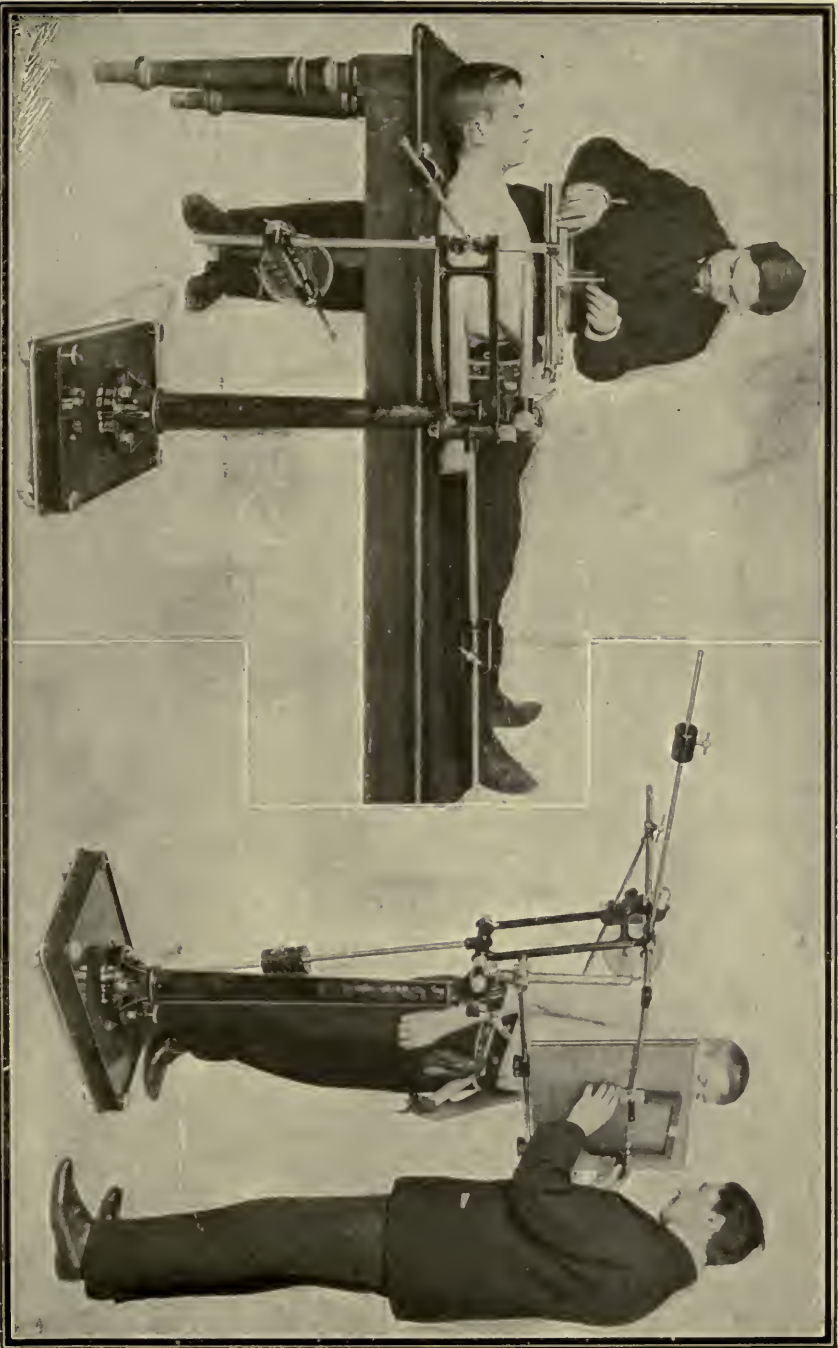

Fig. 179.—Moritz orthodiagraph (horizontal position).

Fig. 180.—Moritz orthodiagraph (vertical position).



contrast. The cardiac outline may be readily differentiated by means of the ingenious artifice of Dr. Disan.<sup>1</sup> By this method the outline of a normal heart is traced on the chest by fixing with adhesive strips a copper wire. A fluoroscopic examination is then made in the following way: At first the greatest strength of current obtainable from the apparatus is turned on. The observer looks through the fluoroscope and gets the chief landmarks of the chest, such as the scapula, ribs, spine, diaphragm, and upper convex border of the liver, the wire being at the same time in full view. The current is now reduced until the heart becomes more distinctly visible. The fluoroscope is applied to a spot marked at the left of the spine, corresponding to the fourth intercostal space in front of the chest. Any alterations in the shape of the heart can thus be easily demonstrated.

The shadows of the pulmonary vessel and in many instances the vena cavæ can be recognized if the chest is made to assume a position diagonal or oblique to the screen and tube.

The pulsations of the heart are less in number during a deep inspiration than in expiration, or even in the ordinary quiet breathing. These pulsations are lessened during a deep inspiration and by increase of the air pressure upon the heart,—*i. e.*, the pressure from the pericardium, which is made more taut during the descent of the diaphragm.

*The Orthodiagraph.*—This instrument was devised by F. Moritz, of Munich.<sup>2</sup> (Figs. 179 and 180.) Its purpose is the bringing out of any object in its exact size and without distortion. By it the size and shape of all the recognizable internal organs, as well as other parts of the body, can be determined. As the Röntgen rays are propagated from a point on the anodal field in straight lines radiating in every direction, and as the image of a body projected on a phosphorescent screen or skiagram is a silhouette, the outline of the object presented coincides with the places where the rays coming in contact with the edge of the body impinged upon the screen. This outline, therefore, is the periphery of the base of a cone, whose point coincides with the luminous spot of the anti-cathode. As the object to be projected is located between the vacuum tube and the screen, the image on the latter will be magnified, the degree of magnification being dependent upon the ratio of the distance of the object from the image plane and the distance of the object from the vacuum tube. The image projected by a vacuum tube, so far from recording the true dimensions and shape of the object, will show the latter more or less magnified and distorted. In order to obtain the true shape and size of the object, the rays touching the body and forming on the plate an image of its outlines must be made parallel and strike the plate at right angles,—*i. e.*, the projection from a centre must be

<sup>1</sup> Dominion Medical Monthly, February, 1897.

<sup>2</sup> Berlin Allgemeine Electricitäts Gesellschaft, and Münch. med. Wochenschrift, April 10, 1900.



replaced by a projection that is parallel. With the orthodiagraph, projections true in shape and size are obtained in any desired position of the drawing-plane.

The luminous screen which also carries the drawing stylus is connected with the Röntgen tube by a U-shaped frame. This frame, made up of a number of jointed sections, permits of any desired adjustment of the screen with the tube. A rod extending from the screen is longitudinally adjustable in a split sleeve on the end of a tube lying parallel with the axis of the drawing stylus. The tube is provided with a telescoping member, on the projecting end of which a second split sleeve is adapted to slide. This screen is formed on the end of an arm which is thereby supported at right angles to the telescoping member. The clamp holding the tube has a ball-and-socket connection with a member which may be adjusted to any position along the arm. When properly adjusted the propagating joint of the X-rays should lie on an extension of the axis of the stylus. This may be done approximately by adjusting the tube clamp and other members of the U-shaped frame. In order to obtain a more perfect adjustment of the tube,—*i. e.*, such adjustment as would permit working with accurate perpendicular rays,—the screen may be adjusted in one plane, by moving its supporting rod longitudinally in the split sleeve above referred to, and in a plane at right angles thereto, by adjustment of the screen within its holder. By noting the shadow cast on the screen by the end of the stylus projecting there through, the operator can readily ascertain when accurate adjustment has been obtained.

Parallel movement of the tube with the screen is obtained by means of two levers, one pivoted to the other. A lever which supports at one end the U-shaped frame is hinged to a second lever, which in turn is pivoted to a bracket on the end of the supporting column of the apparatus. Each lever is provided with a counter-weight, movable along its outer arm, and these weights serve to hold the parts in equilibrium.

The bracket just mentioned also carries a rod, to which the drawing frame is attached by means of a universal joint. The drawing frame is adapted to be covered with heavy bristol-board, held therein by holders at the sides, and on this surface the drawing stylus is softly pressed by a spiral spring.

Now the whole system so far described is movable around the axis in the head of the main supporting column, and may be clamped in any position by means of a milled nut; an additional fixing lever may be grasped to prevent this system from suddenly dropping or loosening the nut. At the same time, the accurately vertical and horizontal position of the system is indicated by a spring catch. The length of the supporting column is such that on turning the system round its axis into a horizontal position, the drawing plate will just be at a convenient distance above a person lying on an ordinary table of about 30 inches in height. The heavy base plate is provided with four rollers allowing of the

drawing apparatus being readily moved. By operating special screws, these rollers may be removed, and the apparatus placed on the points of the screws, which in addition will allow of the column of the apparatus being given an accurately vertical position even on oblique or uneven floors.

When a drawing is to be made directly on the body, the bristol-board is removed from the drawing frame, and a dermatograph stylus should be inserted into the drawing stylus, instead of a pencil. The drawing

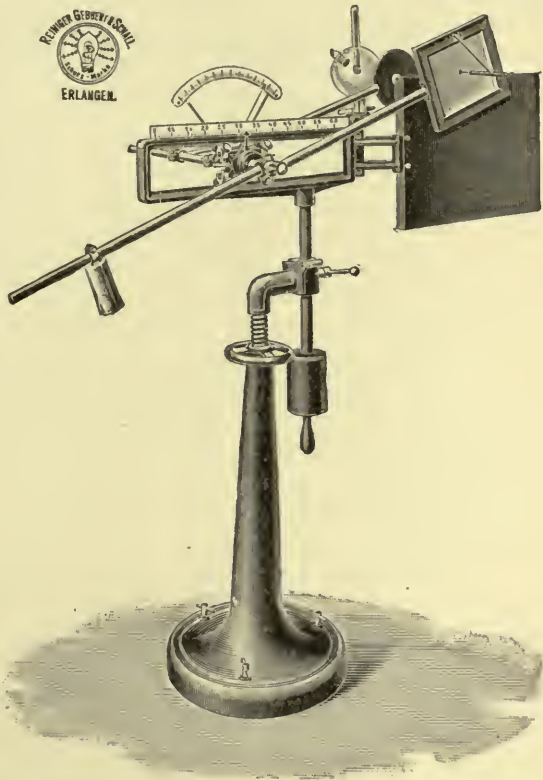

FIG. 181.—Levy-Dorn's orthodiagraph for the standing position.

frame is provided with three pencil-holders, or "plotters," as they are called, which are movable in the plane of the screen or in that of the drawing plate, and provided with scales in both co-ordinates; the position of a person with regard to the central ray may be thereby ascertained, so that on the examination being repeated the same position of the person may be accurately secured. A fourth auxiliary plotter has been provided with slides on a scale projecting from the extended axis of the lower supporting lever.

In addition to reproducing the true shape and size of organs, the apparatus may be advantageously used to ascertain the depth of foreign objects. This can be done by measuring the apparent diameter of the object when the Röntgen tube is stationary, and then ascertaining the actual shape of the body by means of parallel movement of the drawing



Reiniger, Gebbert & Schall, Erlangen.

FIG. 182.—Levy-Dorn's orthodiagraph for use in the recumbent posture.

stylus and the tube. Now if  $al$  is the apparent length of a foreign body,  $rl$  its real length,  $D$  the distance of the anticathode of the tube from the luminous screen, and  $d$  the distance of the object from the anticathode, the formula  $\frac{d - rl \times D}{al}$  will give the true distance of the foreign body from the luminous screen.

The Levy-Dorn orthodiagraph is shown in Figs. 181 and 182. The advantage of this instrument lies in the fact that during the examination of the heart the operator measures the vertical and horizontal axes on the scales.

#### B. SKIAGRAPHIC EXAMINATION OF THE HEART.

The heart can be skiagraphed with the same technic as is applicable to the lung, but the former requires more precision in the position of the patient, tube, distance, etc. The patient may be seated on a chair and the plate placed either over the chest (sternum), in the anterior or

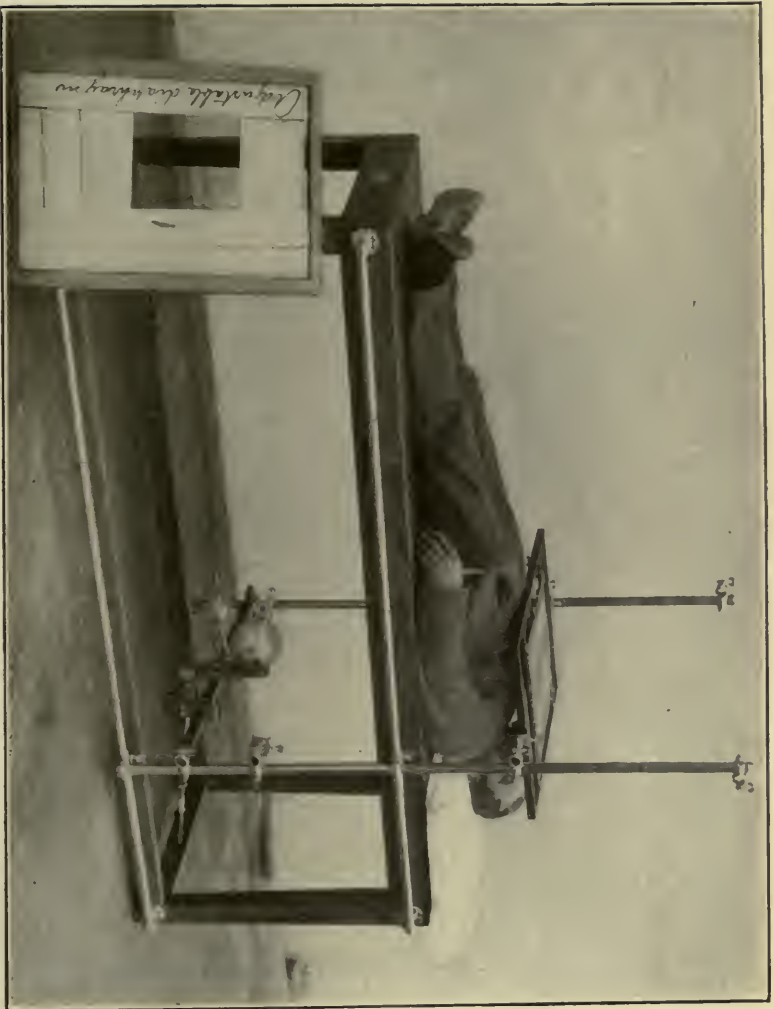

FIG. 183.—AUTHOR'S TABLE FOR SKIAGRAPHING THE HEART AND LUNGS.—Crookes tube under the table and plate over the chest. The plate can be removed and another substituted without disturbing the patient, this being accomplished by the frame, which can be adjusted to any sized plate. Resting against the foot of the table is an adjustable lead cover diaphragm, which is used in treatment.





FIG. 184.—THE SITTING POSITION.—In stereoskiagraphy the plate can be changed without changing the position of the patient, by displacing the tube-holder  $2\frac{1}{2}$  inches. This tube-holder can also be used for holding the fluoroscope.

ventral view, or to the back (posterior view). Ask the patient to raise both arms, in order to remove the shadows of the scapulæ from the thorax. Centre the anode of the Crookes tube over the level of the third rib in back and one inch below the upper end of the sternum in the median line. The distance of the anode from the plate should be from 25 to 30 inches (63-75 cm.). An anterior and posterior skiagraph should be made at the same time, noting that no abnormality or deformity exists. If the tube is placed in an oblique position the shadows will often mislead and confuse. Anterior and posterior oblique (right and left) skiagraphs should also be taken, in order to study mediastinal tumors, and the arch of the aorta. The time of exposure should be as short as possible, correspondingly to the cardiac cycle. Two methods of skiagraphing the thorax are presented in Figs. 183 and 184.

M. Guilleminot, of Paris, invented an instrument by which he can make cinematograph pictures. The exposures can be made either during inspiration, expiration, or during the ascent and descent of the diaphragm; and also during the systole and diastole of the auricles and ventricles. I have made stereo-skiagrams of the thoracic organs of young thin subjects, which have yielded for scientific study the true perspective and relief effects of the heart, aorta, sternum, and vertebræ; such results are of clinical worth in studying aneurisms and cavitations.

*Size and Measurement of the Heart.*—According to Abrams,<sup>1</sup> with the screen at about 29½ inches (75 cm.) from the tube and with the target directed toward a point where the median line is crossed by the fourth rib, the normal heart is seen to extend from the median line  $1\frac{3}{8}$  inches (3 cm.) on the right side and  $3\frac{5}{8}$  inches (8.5 cm.) on the left side, the total width of the heart being about 4 inches (or 10 cm.).

*Mobility of the Heart.*—Silbergleit<sup>2</sup> describes a case in which the entire heart was capable of lateral displacement of several inches by a change from the left lateral to the right lateral position. The patient was a man of twenty-four years who came under observation for gastroenteritis and a moderate degree of chlorosis. He had no subjective symptoms referable to the heart, and in the standing position or when lying on the back physical examination of the organ was negative. When lying on the left side, however, the apex beat was three centimetres outside of the mammary line, and the right border one centimetre to the left of the left sternal margin. When on the right side, the apex beat appeared close to the left sternal margin and the right border was correspondingly displaced. This case is of scientific value, in that the abnormal mobility is only an index of an existing cardiac lesion.

Sears<sup>3</sup> states that Determann's experiments, made with the X-rays and by percussion, demonstrated the mobility of the heart with change

<sup>1</sup> Journal of the American Medical Association, May 3, 1902.

<sup>2</sup> Medical Record, June 20, 1903.

<sup>3</sup> Medical Standard, January 1, 1901.

of position. In the healthy individual turning on the left side produced an average displacement of  $2\frac{1}{2}$  centimetres to the left and 1 centimetre upward; turning on the right side occasioned a change of  $1\frac{1}{2}$  centimetres to the right and about  $\frac{1}{2}$  centimetre upward. In some cases the displacement was quite small, in others as much as  $6\frac{1}{2}$  centimetres to the left and 4 centimetres to the right, without distress to the subject. These greater movements were found to occur, as a rule, in flabby and ill-nourished individuals and in those whose abdominal organs were loosely anchored.

It was observed that women usually have more freely movable hearts than men, especially after childbearing or from the use of tight stays. Children have little signs of it, the newborn scarcely any, and in old persons it is slight. Individuals of sedentary habit and feeble muscular development are especially subject to the condition. The physiological effect of the full stomach is noted, and also anything which tends to elevate the diaphragm. During the latter part of pregnancy the heart is much pushed up and is compressed, thus showing very little mobility. Immediately after delivery, however, the highest grade is found, and the apex may be displaced on the left side 9 centimetres from its original position.

MORITZ TABLE.<sup>1</sup>*Healthy Adult Man (Age 17 to 56).*

HEIGHT OF THE PERSON	DIMENSIONS	Distance from the Median Line to Right	Distance from the Median Line to Left	Long Diameter	Transverse Diameter	Surface Square
		cm.	cm.	cm.	cm.	cm.
153-157 cm. or 5 ft. 9 inches 5 ft. 10½ inches	average	4.4	7.9	13.0	10.2	98
	maximum	4.8	8.0	13.5	10.5	100
	minimum	4.0	7.8	11.5	10.0	80
161-169 cm. or 6 ft. 0 inches 6 ft. 3¼ inches	average	4.4	8.3	13.4	10.5	102
	maximum	5.0	9.3	14.5	10.8	108
	minimum	3.5	7.5	12.8	9.0	87
171-178 cm. or 6 ft. 4 inches 6 ft. 7¾ inches	average	4.6	8.8	14.0	10.3	100
	maximum	5.9	9.7	15.3	11.0	126
	minimum	3.0	7.8	12.5	9.0	92

*Displacement.*—In this condition the heart may retain its normal shape, only changing its position. The most frequent cardiac displacement is dextro-cardia, which is a congenital malposition. In the acquired

<sup>1</sup>H. Gocht, "Handbuch der Röntgenlehre," "Erwachsene gesunde Männer (von 17 bis 56 Jahren)."



forms of malposition the heart may be displaced low down in the chest, the pulsations may be felt behind and below the lowermost extremity of the sternum, or it may be placed to the right of the sternum or the left outside the left nipple line, these facts being confirmed at the same moment with the fluoroscope. Fluid in the left pleural sac causes the heart to be pushed toward the right side, while exactly the opposite condition exists when the right pleural cavity is so affected; but in dry pleurisy the adhesions may draw the heart toward the affected side. Distention of the pleural cavity by gas, as seen in emphysema, also causes a displacement either to the right or the left, depending upon the cavity that is involved. An increased elevation of the diaphragm causes the heart to assume a position on its long axis so that the right ventricle is pulled to the anterior position, the chief feature of recognition being the increased distinctness of the right side of the heart when the chest is examined from behind.

*Cardiac Atrophy, Hypertrophy, and Dilatation.*—These conditions are revealed by a screen examination. Atrophy presents a small size of the organ. In hypertrophy or dilatation of the left ventricle, the apex has changed from its normal position, the shadow area is increased, and the clear space normally existing between the heart and liver (as seen on a deep inspiration) is diminished in size or has totally disappeared. If the right ventricle is increased in size the base usually appears more or less drawn down and the long axis assumes a more nearly horizontal position. Abdominal distention, with either fluid or gas, causes an elevation of the diaphragm, hence another cause for change in the position of the heart. I have often noticed that the heart atrophies in advanced cases of tuberculosis. In a pneumonia, displacement is usually toward the unaffected side; in an extensive emphysema the heart naturally occupies a position lower than normal. Aneurisms, new growths, and adhesions are among the other causes of cardiac displacement. Thorne<sup>1</sup> observed a heart to shrink after its exposure to the Röntgen rays for thirty minutes. In one case, the heart had shrunken in its long axis some  $1\frac{3}{4}$  to 2 inches (4.5 to 5 cm.), while in its transverse diameter the contraction amounted to  $1\frac{1}{2}$  inches (4 cm.). Experiments in this connection have been conducted on dogs, the results in general showing a considerable shrinking.

Care should be taken when fluoroscoping the heart to differentiate between true atrophy and displacement. In the Schott treatment of heart disease, the attendant studies the patient's heart before and after each treatment. I have never observed any change in the size of the heart except an alteration in the pulse rate noted in certain neurotic cases.

*Acute Dilatation of Heart.*—F. Moritz<sup>2</sup> stated that orthodiagraphy has failed to confirm the occurrence of any appreciable acute dilatation after

<sup>1</sup>British Medical Journal, 1896, vol. ii. p. 1238.

<sup>2</sup>Münchener medicinische Wochenschrift, lii., No. 15, April 11: "Acute dilatation of the heart due to diphtheria."



physical exertion, after hot baths, the injection of alcohol, narcotic or other medication; chloral, chloroform, caffeine, or kola. It has revealed, however, that the outline of the heart is smaller in the upright position than when the subject reclines. He believes that an interesting field for research is opened by orthodiagraphy of the dilated heart, whereby we can study the influence exerted upon it by rest in bed, digitalis, carbonated baths, electric baths and gymnastics, etc. H. Dietlen<sup>1</sup> states that he has examined 47 out of 65 patients suffering from diphtheria with the aid of the Moritz orthodiagraph, the subjects reclining, and he found that 20 of these 47 presented evidences of myocarditic phenomena. In 15 of this group (75 per cent. of the cases of endocarditis and 32 per cent. of the total number), dilatation of the heart was unmistakably apparent when examined with the orthodiagraph. Even extreme degrees of dilatation are liable to retrogress, so that the prognosis is not necessarily bad.

*Examination of the Heart.*—Kraus<sup>2</sup> has analyzed the findings of radioscopy of the heart in health and disease. He asserts that the shades of difference between the heart shadows cast in cases of various valvular affections are of greater diagnostic importance than dilatation of the heart alone. These differences in shadows are due to changes in the shape of the various sections of the heart, the immediate consequence of the valvular defect. The consecutive hypertrophy of the musculature and passive dilatation naturally reinforce and emphasize, as it were, the differences in the outline. This is especially marked in the left convex protrusion of the so-called left middle arc in case of mitral defect, also in the varying behavior of the left lower arc with mitral insufficiency and pure mitral stenosis, and, finally, in the outline of the shadow as it spreads to the right, in case of aortic and mitral defects. Radioscopy of the heart after artificial distention of the stomach is very instructive. The presystolic pulsation of the right auricle can be distinctly distinguished from the contraction of the ventricle. Two and sometimes three contractions of the auricle to one of the ventricle are sometimes noted. Intermittence of the heart is seen to be by no means always identical with intermittence of the pulse. In cases of tachycardia and bradycardia radioscopy throws light on many hitherto unexplainable processes, especially those of nervous origin.

*Pericarditis (Pericardial Effusion).*—If an enlarged shadow is cast by the cardiac area, it indicates hypertrophy, or a pericarditis with effusion. If there is presented a movement of the left border of the heart's shadow, it indicates enlargement. In case no such pulsation is demonstrable, pericarditis with an effusion should be surmised. The shadow of a

<sup>1</sup>Münchener medicinische Wochenschrift, lii., No. 15, April 11, 1905: "Acute dilatation of the heart due to diphtheria."

<sup>2</sup>Deutsche medicinische Wochenschrift, Berlin and Leipsic, xxxi., No. 3, January 19; Journal of the American Medical Association, June 10, 1905.

pericardial effusion is rounded or circular, while that of hypertrophy is more or less pyriform. In most cases the shadow cast by an effusion is not so dense as that produced by the heart muscle itself, so that in viewing the shadow field we may find a variety of shades ranging from a slightly lighter field to one that is dark. A change in the upper level of the shadow may occasionally be noticed by changing the position of the patient.

*Aortic Aneurism.*—Cases of aneurism, unsuspected and unrecognized by the attending physicians, have been revealed by careful fluoroscopic and skiagraphic examinations. While aneurisms are sometimes undetected by X-ray examinations, a large number are supposedly diagnosed that in reality do not exist; an early diagnosis, therefore, is most important. The prognosis of aneurism was formerly regarded as most unfavorable, but in the light of recent knowledge the so-called "commencing aneurisms of the aorta" have been shown to remain often stationary, and that they do not necessarily proceed to a fatal termination. They can always be studied during treatment as to their size, position, pulsation, etc.

Fluoroscopic examinations are preferred by most operators because they are enabled to see the tumor or pulsating condition and because the condition can be examined from different angles and positions. Both methods should be employed, although I never use the fluoroscope.

The skiagraphic examination is identical with the technic described on diseases of the lungs and heart.

The shadow of the normal aorta (when viewed anteriorly or posteriorly) is almost totally obscured by the superimposed shadows of the sternum and the vertebral column, with the exception of a small shadow to the left, cast by the left lateral aortic bulge.

Aneurisms of the *ascending* portion of the arch of the aorta, being nearer to the anterior wall of the chest than the posterior wall, cast shadows extending to the right of the sternum and above the heart.

Aneurisms of the *descending* portion of the arch of the aorta (Figs. 185 and 186) usually cast shadows to the left of the sternum, which are nearer the posterior than the anterior wall of the chest. If the aneurism is very large, the shadow will extend to both sides of the sternum.

Aneurisms of the *transverse* portion of the arch of the aorta will cast shadows slightly to the left, and if large the shadow observed will extend up to the neck. This detection, however, is very difficult, and requires, in addition to anterior and posterior examinations, left lateral and right lateral oblique examinations.

Beginning or diffused aneurisms are difficult of diagnosis, especially so in corpulent individuals. Goelt<sup>1</sup> declared that by means of the

<sup>1</sup> Lehrbuch der Röntgenuntersuchung, Stuttgart, 1898, p. 199.

Röntgen rays it was possible to determine the presence of an aneurism where doubtful symptoms were manifested.

Dumstrey and Metzner<sup>1</sup> urged considerable caution in reaching conclusions regarding the existence of aneurisms by means of the Röntgen rays, especially where physical signs or symptoms failed to be elicited; they furthermore believe that mediastinal tumors may give rise to the same appearance.

Drs. Geo. Pfahler and Jos. Sailer<sup>2</sup> assert that, after a careful comparative study with X-ray diagnoses and post-mortem examinations of supposed aneurisms, they found that the tortuosity of the aorta was in many instances confounded with the existence of aneurisms.

Dr. G. H. Orton<sup>3</sup> says that, "In some cases, even with these four examinations, the shadows of the aorta cannot be satisfactorily inspected, owing to complications which may mask it."

Of late, I am making stereo-skiagrams of the chest, and find them valuable in differential studies involving the aorta, heart, and lungs in their respective relations to each other and to the bony thorax.

In many cases of small aneurism, the oblique method of examination should be employed. This has been well described by Holzknacht and Bécélère:<sup>4</sup> "It consists in rotating the patient so that the rays penetrate the chest obliquely. If the screen is placed on the left of the patient and the tube on the right side, the pericardial shadow is bounded by two clear spaces; the retrosternal in front, and the retrocardiac behind. In this position the inferior parts of the ascending and descending aorta can be seen, but the arch is hidden by the shadows of the shoulder muscles and vertebral column.

"Now if the patient is rotated so that the rays penetrate the chest at an angle of 45° forward and from left to right, the best position is obtained. In this position the cardiac shadow is angular, the base continuous with the diaphragm, the superior angle prolonged into a vertical offshoot, caused by the superimposed shadows of the ascending and descending parts of the arch. In this position many cases of supposed aneurism which show the marked aortic bulge in the antero-posterior examination are shown not to be true aneurisms. In suspected cases the examination is not complete until this method has been employed."

Another important sign in the diagnosis of aneurism, first pointed out by Walsham, consists in a change in the position of the heart, which comes to lie more transversely, the right side being apparently pushed down by the aneurism, with a tilting upward of the apex. Orton, likewise, regards the position of the heart as a very valuable and constant

<sup>1</sup> Fortschritte auf dem Gebiete der Röntgenstrahlen, vol. i.

<sup>2</sup> The American Journal of the Medical Sciences, October 1, 1903.

<sup>3</sup> Archives of the Röntgen Ray, August, 1905.

<sup>4</sup> Archives of Physiological Therapy, October, 1905.





FIG. 185.—Aneurism of the descending aorta (posterior view). Plate applied against the back of the chest.

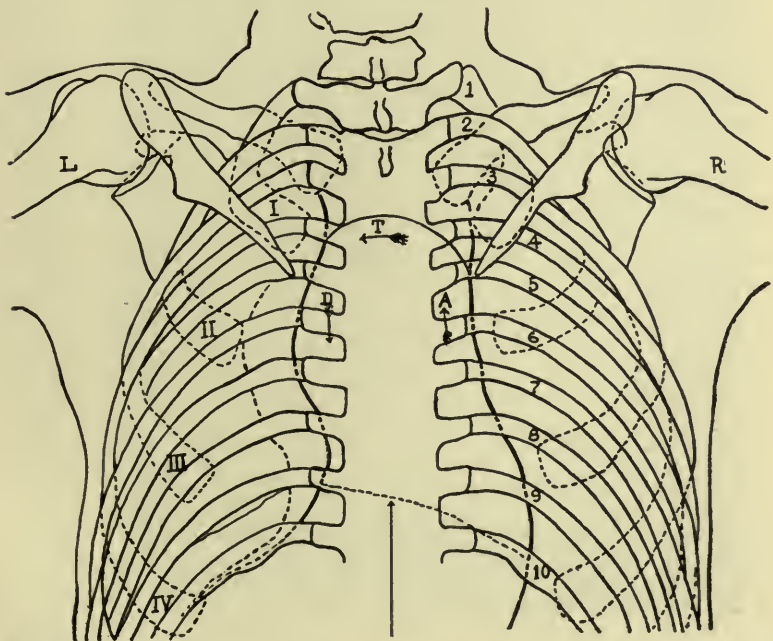

FIG. 186.—Photographic tracing of the same. Heavy lines, outlines of normal heart; dotted lines, dilatation of the descending (D  $\leftarrow$ ) aorta. Observe the horizontal position of the heart, due to aneurismal pressure. A  $\rightarrow$ , ascending aorta; T  $\leftarrow$ , transverse aorta.





Fig. 157.—Dilatation of the heart, with aneurism of the aorta. Dotted lines show the aneurism of the descending portion of the arch and dilatation of the left auricle and ventricle. Heavy outline shows (approximately) the size and contour of the normal heart. Plate placed in front of the chest (anterior view).



Fig. 158.—Atheroma of the femoral artery.

sign. There are shadows that may exist either to the right or left of the sternum which may be confounded with the diagnosis of aneurism.

1. Dilatation of the aorta (not aneurismal).
2. Displaced aorta (dislocated).
3. Enlarged glands.
4. Neoplasms.
5. Pulsating empyema.

1. *Dilatation of the Aorta* (Fig. 187).—This condition is often confounded with aneurism; the shadow cast will be on either side of the sternum, the diagnostic point being that this pulsating shadow will disappear between the pulsations (the diastole); because with the contraction of the aorta the shadow thrown will be smaller, or it will be completely hidden by the shadows cast by the sternum and vertebral column. In this differentiation the fluoroscopic examination will prove more useful than will the skiagraph.

2. *Displaced Aorta*.—This condition usually appears to the left of the spinal column, a pulsating shadow being evidenced as far as five or six inches to the left of the border of the sternum. This is a much greater area than will be projected by the aneurism of the arch.

Abnormalities of the thorax and spine should be excluded.

3. *Enlarged Glands*.—Enlarged lymphatic and bronchial glands cast scattered shadows, with absence of the characteristic expansile pulsations.

4. *Neoplasms*.—Mediastinal growths, *i. e.*, carcinoma and sarcoma, can be differentiated, in that the latter cast darker or denser shadows, the edges are hazy, indistinct, and uniform, and by the absence of expansile pulsations. Care should be exercised not to overlook transmitted pulsations.

5. *Pulsating Empyema*.—Pulsating empyema and other intra-thoracic abscesses will be differentiated by the history, their location, and form.

Aneurisms of the abdominal aorta cannot be well demonstrated in corpulent persons, owing to lack of contrast with the surrounding tissues, as the shadows of the aorta and vertebræ superimpose, when skiagraphed in either the ventral or dorsal positions. Lateral and oblique positions are always advisable in skiagraphing this condition.

*Atheroma*.—Atheroma and calcification of the blood-vessels can be well demonstrated. (Fig. 188.)

## CHAPTER V

### APPLICATION OF THE X-RAYS IN DISEASES OF THE ABDOMINAL ORGANS.

#### I. Alimentary System.

THE employment of the X-rays in the diagnosis of diseases of the alimentary system has not as yet yielded the same results or been as easy of application as is evidenced in diseases of the thoracic organs, for the obvious reason that there exist no tissue differences.

There are various means of producing the necessary contrast or difference between these soft tissues: (1) by gaseous distention, which renders the stomach more translucent; (2) by the introduction of opaque instruments or mechanical methods; (3) the bismuth subnitrate method, by which the organs become more opaque; (4) the transillumination method, which consists in illuminating the stomach by the introduction of fluorescent materials, radium, etc.

#### A. ŒSOPHAGUS.

In order to examine this tubular muscular organ, for its position, direction, etc., we may introduce a rubber sound with a metal point, or a rubber tube filled with mercury or fine shot.

The fluoroscopic examination should be made with the patient in the semi-recumbent or standing position, so as to prevent the superimposition of the shadows cast by the vertebræ, heart, aorta, etc. Allow the shadow to fall on a clear area and apply the fluoroscope obliquely over the right and left sides, and also in the right and left antero-lateral positions.

Skiagraphic examinations should be made in the same positions as in the fluoroscopic method, but the posterior position is more comfortable for the patient.

*Stricture of the Œsophagus.*—Constrictions of the œsophagus can be best ascertained by the introduction of a bougie with metallic ends, or by the use of a metallic sound, and viewing its passage in the above manner.

*Stenoses of the Œsophagus.*—Barba<sup>1</sup> reports two cases of œsophageal stenoses, in which he made radiosopic observations. The chief point brought out in his study is, that the ordinary methods of examination for stenosis of the œsophagus (the most important of which is the use of sounds) do not enable us to differentiate an organic stenosis of the canal from a narrowing occasioned by the pressure of tumors in the mediastinum or by other causes of compression. The presence of these causes of

<sup>1</sup> *Riforma Medica*, December 23, 1905.

compression in the mediastinum is very difficult to determine by physical examination, and only the Röntgen rays enable us to make an accurate diagnosis. In the two cases reported, radioscopy showed that the stenosis, in each, was caused by the compression of tumors in the posterior mediastinum. In both cases, the radioscopic examination was aided by the passage of a sound filled with a concentrated solution of bismuth subnitrate, or else provided with a metallic stylet.

*Diverticulum.*—A diverticulum may often be diagnosed by the above method. The bougie or sound may not enter into the pouch, however, when it becomes necessary for the patient to drink bismuth suspended in water; one to two parts to 100 parts of water. When possible, skiagraphs should be taken, as it requires but a few minutes and the operator does not endanger his hands.

*Tumors.*—Dr. Hugh Walsham<sup>1</sup> reports two cases of carcinoma of the œsophagus. He says that, "we must not expect so definite a shadow as seen in cases of aortic aneurism." The diagnosis of an œsophageal growth is more difficult than that of aneurism.

Before the screen examination he gives the patient two drams of carbonate of bismuth, suspended in a little milk or mucilage. This will map out the seat of the obstruction, whilst the topography of the œsophagus can be traced by a metallic bougie.

#### B. STOMACH: SIZE, SHAPE, AND POSITION.

*Examination by Aid of Gaseous Distention.*—This method consists in distending the stomach by the ingestion of certain chemical agents which upon reaction result in the evolution of gases. The chemical most frequently employed is Seidlitz powder. Upon the fluoroscope the stomach appears as a dark area, upon the negative as a light area. This method causes the distention of the stomach walls and the displacement of the surrounding organs, so that little information can be gained by this procedure.

*Mechanical Method.*—In this method, a rubber tube containing a spirally coiled wire is introduced through the mouth into the stomach. Turk's gyromele is a device employed to determine the outline of the stomach by fluoroscopic means.

Neumann<sup>2</sup> uses a Politzer rubber bulb with a soft stomach tube for aspiration of the stomach contents. After the stomach has been emptied and a clean bulb attached to the tube, it is possible to determine the outline of the stomach with great precision, by listening to the sound when air is forced from the rubber bulb into the stomach. A small amount of air is sufficient for the test, thus avoiding distention of the organ. In every instance radioscopy confirms the findings of auscultation as

<sup>1</sup> Archives of the Röntgen Ray, April, 1903, p. 114.

<sup>2</sup> Journal of the American Medical Association, July 23, 1904.



the bulb is compressed and the air forced into the stomach. This test is useful in dubious cases in the differentiation of gastric from intestinal stenosis.

*The Bismuth Subnitrate Method.*—This method consists of the ingestion of subnitrate of bismuth, either mixed with food suspended in water, or administered in capsule form. This method was introduced and first employed by MM. J. Ch. Roux and Balthazard.<sup>1</sup> In 1897, F. Williams, of Boston, applied this method most extensively. The employment of the bismuth test, at the present time, is universal.

*Technic of the Bismuth Method.*—Chemically pure bismuth subnitrate should always be employed. Cases of poisoning, though not fatal, have been reported where the impure salt was taken. The stomach should be empty, no water should be partaken of, and the bowels should be thoroughly purged twenty-four hours prior to the examination. Roux and Balthazard use bismuth subnitrate in the proportion of 0.20 per cubic centimetre. Williams has administered as much as one ounce of bismuth emulsion. Hultz gives the patient the bismuth in a pint or more of milk. Boas advises the partaking of bread and milk or of potato soup, into which has been stirred one ounce, or more, of the bismuth salt.

*Fluoroscopic Examination.*—Williams recommends examination of the patient with the fluoroscope, as “the stomach moves during respiration, and therefore its outlines are blurred on the radiograph.”<sup>2</sup>

Holzknrecht and Brauner<sup>3</sup> assert that the passage of a bismuth tablet into the stomach can be traced and its expulsion watched, and that “the action of massage on the stomach, displacement of the organ during respiration, etc., can be better studied by a fluoroscopic examination.”

I do not employ the fluoroscope, as it is dangerous alike for the operator and patient, and because the taking of a skiagraph is only a question of seconds. A severe X-ray dermatitis occurred in the hospital while the attending physician and my assistant were examining such a case with the fluoroscope.

*Skiagraphic Examination.*—The patient lies over a 14 x 17 inches (35 x 43 cm.) plate, a penny being placed over the umbilicus and then secured by adhesive plaster. The patient must remove his clothing. The ventral or dorsal decubitus, sitting, standing, or semi-recumbent position may be employed.

In the ventral position, the anterior wall of the stomach comes in contact with the plate. In the dorsal position, the posterior wall will be nearer to the plate. In the sitting or standing position, the weight of the bismuth will depress the lower border of the stomach, so very important in the study of cases of gastroptosis. The ventral position is to be

<sup>1</sup> C. R. de l'Académie des Sciences, 1896. Bouchard, *Traité de Radiologie Médicale*, p. 995.

<sup>2</sup> Williams, *The Röntgen Rays in Medicine and Surgery*, p. 367.

<sup>3</sup> Wiener klin. Rundschau, 1905, vol. xliv. p. 1971.

preferred, because the bismuth adheres upon the anterior gastric wall, presenting clearly the fundus, the cardiac end, and the general contour of the organ.

The Crookes tube should have a high vacuum. The anode is placed perpendicularly over the third and fourth lumbar vertebræ, at a distance of 20–25 inches (50–63 cm.) from the plate.

*Time of Exposure.* — The time of exposure should be as short as possible, because of the danger of blurring, occasioned by peristalsis and from the diaphragmatic movements. The exposure can be made sufficiently short either after a full inspiration or after a forced expiration. Narcotics to lessen peristalsis are seldom necessary. In corpulent subjects, especially when the apparatus is inadequate, the intensifying screen can be used; but when a fine negative, full of detail, is to be brought out, the granularity produced by the screen is a serious disadvantage. I employ a high-vacuum tube, with an electrolytic interrupter, duration 3 to 15 seconds, thus allowing the patient to hold his breath after a full inspiration.

Dr. Henry K. Pancoast<sup>1</sup> reported the cases of 40 patients, suffering with gastric or gastro-intestinal symptoms. The technic he employs is as follows: "Bismuth subnitrate held in suspension in mucilage of acacia (proportion of two ounces of the powder to the pint) (or 64 grams to one-half litre) was either poured into the stomach through the stomach tube or was swallowed by the patient; the latter method was principally used. The bulk of the bismuth-acacia mixture varied from six to thirty-two ounces (190 to 700 grams). Immediately after the bismuth had reached the stomach the pictures were taken, the patient being in the standing position, and the plate in contact with the anterior abdominal wall.

"The rays were thrown posteriorly, the patient holding the breath during full inspiration for an exposure of eight to fifteen seconds; thus eliminating blurring by respiratory and peristaltic movements. After the picture has been taken, it is advisable to siphon the bismuth mixture out of the stomach.

"In several cases as much as four ounces of bismuth was left in the stomach with no unpleasant symptoms; but on the other hand, six cases showed toxic symptoms after this amount had not been removed. For the purpose of obtaining the lower border and segment of the stomach, six ounces of the emulsion containing one ounce (32 grams) of bismuth is sufficient. This amount has been left in the stomach with no bad effects."

Dr. Joseph Sailer, of Philadelphia, has reported untoward symptoms following the administration of bismuth. The symptoms varied, but cyanosis, dyspnea, nausea, etc., were noted in several patients. The

<sup>1</sup> University of Pennsylvania Medical Bulletin, August, 1906.

presence of antimony and arsenic was excluded, and it was thought that the rays had a peculiar action on the trypsin, with disintegration of the subnitrate. Undoubtedly the action only started after the bismuth had been for some period in the intestine, and had been acted upon by the ferments present.<sup>1</sup>

Dr. Henry Hultz<sup>2</sup> asserts that: "Immediately after the bismuth meal two dorso-ventral exposures are to be made, one in the standing or sitting position, and one in the recumbent position. Assuming that the first Röntgenographs were taken at noon, the next one should be made about six hours later, the patient having partaken of neither fluids nor solids since the noon hour."

He employs the following technic: A 16-inch coil, Wehnelt interrupter, but one intensifying screen, a strong tube yielding Walter six rays, placed 20 inches (50 cm.) from the plate. He succeeded easily in skiagraphing the stomach of a medium-sized subject in one second, and obtained a very good plate taken under the same conditions but without the use of intensifying screens in three seconds. He prefers an exposure of ten seconds without the screen.

Holzknacht and Brauner<sup>3</sup> recommend the following technic: The views are taken standing and reclining and during inspiration and expiration; the most important information generally being obtained by radioscopy. To examine the standing patient, the Röntgen tube and the fluorescent screen are suspended by weights from a wooden standard, parallel to each other. The patient swallows a tablet of bismuth and, after its course has been traced, he drinks 50 grammes of water into which 10 grammes of bismuth have been stirred. After the findings of this test have been noted, the patient is directed to drink a mixture of 4 grammes of tartaric acid and 5 grammes of sodium bicarbonate. On the following day, the patient is given 400 grammes of milk gruel containing 35 grammes of bismuth while he reclines on the left side, with the Röntgen tube applied to the dorsal aspect of the body; subsequently he is examined when lying on the right side and again when in the dorsal posture.

Hemmeter of Baltimore<sup>4</sup> has recently used the following method: "The dilated stomach is coated internally with bismuth subnitrate by means of a powder blower, after which its outline can be distinctly recognized through the fluoroscope."

Rieder<sup>5</sup> says: "Let the patient swallow a mixture of 10 or 15 grammes of bismuth subnitrate suspended in 50 c.c. of water, and observe deglutition by the fluoroscope. The act of swallowing may be studied more leisurely if a small quantity of the bismuth salt be given in a pill. For

<sup>1</sup> University of Pennsylvania Medical Bulletin, August, 1906.

<sup>2</sup> Transactions of the American Röntgen Ray Society, 1906, p. 45.

<sup>3</sup> Wiener klin. Rundschau, vol. xlv. p. 1971.

<sup>4</sup> Diseases of the Stomach, p. 640.

<sup>5</sup> Münchener med. Woch., epitome in Medical Record, Feb. 10, 1906.



more exact observation, a bismuth meal is employed. Thirty grammes of bismuth subnitrate are mixed with a little milk and this is then added to 300 or 400 grammes of flour gruel, sweetened with milk-sugar to obviate constipation."

Dalton and Reid<sup>1</sup> obtain the position of the stomach by the employment of an œsophageal tube containing bismuth.

*The Transillumination Method.*—This method consists in introducing some radio-active substances, or an electric light or air into the stomach, and then viewing the viscus with the fluoroscope or by taking a skiagraph.

Max Einhorn<sup>2</sup> remarks that: "Transillumination into the stomach can be demonstrated with Kahlbaum's barium platino-cyanide, or by means of a photographic plate. The latter method has the advantage that no dark room is required and that the result obtained is visible to every one, leaving nothing for imagination or speculation.

"In order to procure a radium photograph of the stomach I proceed as follows: The patient should be in the fasting condition (empty stomach). The radio-diaphane, containing 0.05 gm. (or more) of pure radium bromide, is introduced into the stomach. The patient occupies a recumbent position, and a photographic plate is put directly over the gastric region and allowed to remain there for one or two hours, according to the requirement of the case. The plate is then removed and the radio-diaphane withdrawn. The plate is then developed.

"Contrary to my expectations, radium enclosed in a quartz flask failed utterly to transmit the photographic rays, while thin ordinary glass answered the purpose very well.

"The shortest time for obtaining a photographic outline of the stomach is one hour; in less than an hour hardly anything is visible; one and a half to two hours bring out the outlines more distinctly. Insufflation of air into the stomach occasionally aids in obtaining a good picture.

"A few of the better radium photographs in my possession are reproduced herewith and show that transillumination of the stomach by means of radium is feasible. It is even possible to recognize an area of light which had to pass through the posterior wall of the stomach and the back of the thorax. One of my negatives shows a key which was hanging below the left scapula and was thus photographed by the transmitted light from the stomach.

"Considerable sized tumors of the stomach or liver can, sometimes, be recognized on the picture by the diminished translucency. Thus far, however, I have not succeeded in obtaining definite outlines of the growth."

Sinclair Tousey<sup>3</sup> finds the radio-active and fluorescent solutions, as

<sup>1</sup> Lancet, April 1, 1905.

<sup>2</sup> Archives of Physiological Therapy, Sept. 1905, p. 115.

<sup>3</sup> New York Medical Journal, May 21, 1904.



prepared by him with quinine bisulphate and fluorescein, are innocuous when given by the mouth or subcutaneously, but do not produce singly, or in combination, sufficient fluorescence to be of value in the examination of the stomach without the use of some additional light to excite their fluorescence. In some cases, however, they will be of the greatest assistance in the diagnosis of stomach lesions, and at times of advantage in X-ray treatment.

In cases of gastroptosis, I have had experience with this method at the Philadelphia Hospital, where it has not afforded me any satisfaction.

### C. THE CLINICAL APPLICATION OF THE RAYS.

*Stomach.*—The behavior of the stomach during digestion has been studied with the X-rays on cats and dogs by W. B. Cannon.<sup>1</sup> The outline of the stomach was reproduced on the screen by giving the animal small, but frequently repeated doses of bismuth subnitrate. After a plentiful feeding the viscus was observed to be considerably larger, gradually diminishing in size as the process of digestion proceeded; at the same time, the cardiac end acted as a reservoir for the ingested food while the pyloric region presented marked peristaltic movements. It was further noted that liquids soon pass from the stomach, while solids remain there for an indefinitely longer period.

The activity of the digestive juices can be determined by giving the patient a small quantity of bismuth in a small capsule of gold-beater's skin or gelatine. As the patient swallows, the shadow of the opaque spot is demonstrable on the fluorescent screen so long as the capsule is intact. When the gold-beater's skin has been disintegrated by the action of the digestive juices, the particles of bismuth become diffused and the black spot is no longer seen on the photographic plate or screen. The time occupied by the digestion of the capsule is a measure of the activity of the stomach and the quality of the peptic juices.

Repeated examinations will reveal the time that is required to empty the contents of the stomach. The bismuth accumulates near the pyloric end and passes to the intestines. This consumes a period of about 6 or 7 hours.

*Position of the Stomach.*—Butler<sup>2</sup> asserts that: "The lower border of a normal but much distended stomach may be found at the level of the navel. If below the umbilicus the condition is abnormal." Quain believes that: "It is generally a little (half an inch to an inch) above the highest point of the iliac crest, and about opposite the disk between the third and fourth lumbar vertebræ."<sup>3</sup> The shadows of the normal stomach being approximately known, any increase or decrease in the interval from

<sup>1</sup> American Journal of Physiology, vol. i., May 1, 1898.

<sup>2</sup> "Diagnostics of Internal Medicine," p. 543.

<sup>3</sup> Quain's Anatomy, vol. i., p. 679.

the umbilicus will inform the skiagrapher of any abnormal gastric position. When the tube is at a distance of 20 inches (50 cm.) the distortion will be very small.

Holzknacht,<sup>1</sup> however, believes that: "A stomach which is of normal size and situated in the normal position is rarely visible; but when gastroptosis occurs the stomach becomes visible. When the walls of the stomach are infiltrated with carcinomatous deposits, abnormalities in the contractions of the organ are readily observed, when food mixed with bismuth is given to the patient."

Rieder had large quantities of bismuth mixed with the food and given in enemata, and then examined the patients with the screen. His deductions are contrary to the teachings of text-books. When the stomach is full, the pylorus, for instance, may be found to the left of the median line. The full stomach lies vertical or diagonal, never horizontal. There is always an accumulation of gas to be noted in the upper part of the fundus during stomachic digestion. He also observed interesting facts concerning the motor functions of the stomach and of the various parts of the intestines.

*Gastroptosis.*—This condition is best shown skiagraphically (Fig. 189) while the patient is sitting or standing, or in both dorsal and ventral positions; otherwise the condition may not be detected. Often there will be a difference in the position of the stomach depending upon whether the skiagraph is made after full inspiration or after full expiration.

The form, size, and shape of the stomach can be ascertained by a careful study of the normal stomach and then by comparing it with any supposed abnormality, being careful that the technic is identical in each case.

G. Leven and G. Barret<sup>2</sup> studied the outlines of the stomach by following the path of a bismuth pill, and came to the conclusion that: "Our ideas of the shape of the stomach in life demand revision, also that the lower curve of the organ does not sweep across the abdomen, but that the cardiac end has a small amplitude from which the line runs inward, then sharply down to, or below the umbilicus, and as sharply up again towards the pylorus.

"The form of the stomach has therefore not the regular lines hitherto drawn, and such as we see after death; but the superior part is diminished in size by the dilatation of a tube-like process going downward from the lower border towards the navel."

The authors aver that in the normal stomach this tubular part receives fluids till it is full. When more liquid is added, the tube begins to expand, so that the level of the liquid remains constant for a time, when the latter finally invades the rest of the cavity of the stomach. On

<sup>1</sup> Berliner klin. Wochen., February 28, 1906.

<sup>2</sup> Presse Médicale, Paris, January 31, 1906.

the other hand, in a dilated stomach the authors' characteristic method of filling is not evident; the fluid collects in the lower curve of the viscus, and the level rises slowly and regularly.

*Stenosis of the Pyloric End.*—When the average time which is necessary for the passage of the food (bismuth) for a normal stomach is prolonged (over 6 hours), it is indicative of stenosis of the pyloric end, or of gastric insufficiency, either caused by dilatation or atony. The skiagrapher should make several exposures to determine the time required to empty the stomach.

#### D. INTESTINES.

If only the stomach is to be examined, the bismuth can be pumped from the stomach after the skiagraphs are made; if allowed to remain for three, six, or eight hours, the bismuth passes into the intestinal canal in 15 or 20 hours. It is possible to obtain skiagrams of the colon and other portions of the intestinal tract.

Rieder<sup>1</sup> declares that: "For the large intestines, rectal injections may be used; and that by the use of one litre of fluid containing bismuth it is possible to insure penetration as far as the ileo-cæcal valve."

*Sounding and Radiography of the Large Intestine.*—Schüle<sup>2</sup> has been testing various sounds, including Kuhn's flexible spiral sounds and also the Kassel soft tubes with flexible metal guide, terminating in a button  $2\frac{1}{2}$  to  $3\frac{1}{2}$  inches (5.5 to 8 cm.) in circumference, thus obviating all danger of perforating the intestinal wall. His conclusion is, that no convincing proof has been obtained, to date, that a sound has been successfully passed into the descending colon, to say nothing of the transverse portion. The innumerable folds, windings, and swellings of the intestine render it impossible to determine whether an obstacle to the progress of the sound is of a natural or a pathological nature. On the other hand, the direct visual inspection of the rectum and the sigmoid flexure by the J. Schreiber and H. Strauss technic is perfectly reliable. Schüle found that "high injections" were practicable, the best vehicle being oil. An injection in the knee-elbow position of 300 to 400 c. c. of oil with 125 gm. of bismuth subnitrate, followed by radiography, showed that the oil had penetrated to the ileo-cæcal valve. In two of the patients there was pronounced enteroptosis, the transverse colon in one hanging suspended like a garland from the two points of attachment at each end, the centre reaching far below the upper plane of the pelvis. On account of the small amount of the oil injected, and the fact that the subject was in the knee-elbow position at the time, the injection could not have been responsible for the sinking of the intestine. The radiograms show perfectly the topography of the colon for its entire extent. They also prove

<sup>1</sup>Münc. med. Woch., epitome in Medical Record, February 10, 1906.

<sup>2</sup>Archiv f. Verdauungs-Krankheiten, Berlin, last indexed page 863.



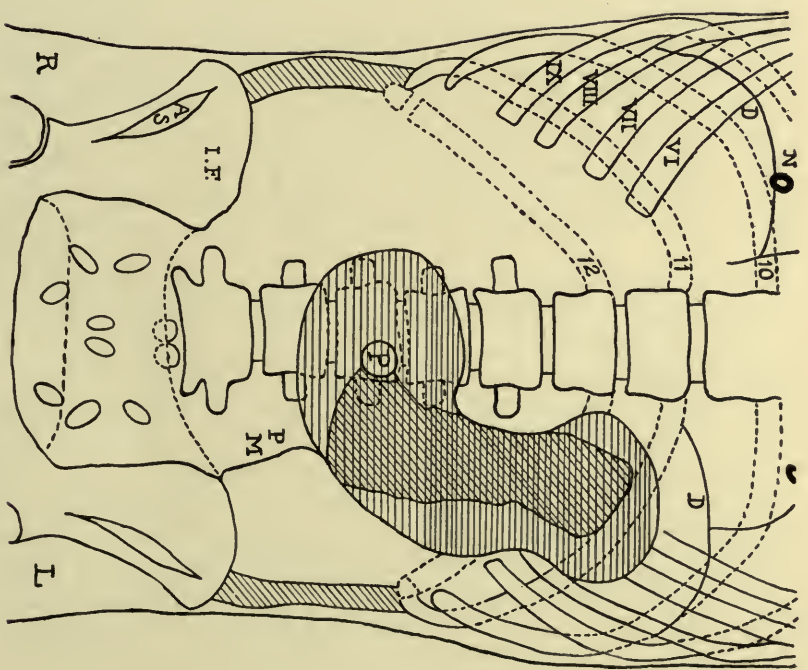
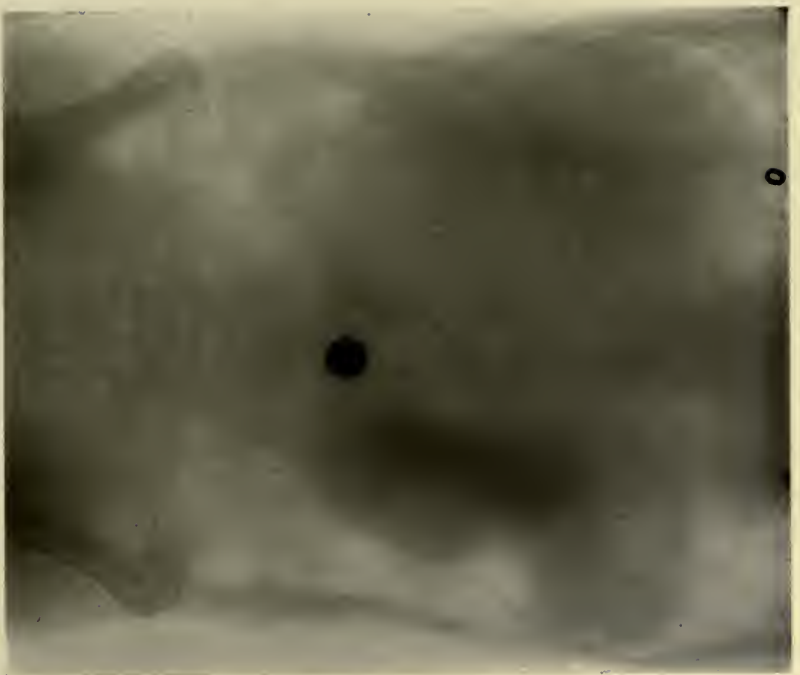

Fig. 180.—A case of gastropnoxis. Mashed potato mixed with bismuth one-half ounce (15 grams) was ingested; two glasses of water were then swallowed. Plate placed against the abdomen; a penny was secured over the umbilicus with adhesive plaster; small lead rings encircled the nipples. In the erect position the enlarged stomach descended greatly; but this patient, having tuberculosis, could not stand erect. The right-hand cut is a tracing of the same. Cross-hatched area is the enlarged of the bismuth mixture; the horizontal-shaded portion is the shadow of the water. The stomach appears very wide, because of its pressure against the anterior abdominal wall (the patient lying upon his abdomen). I. F., iliac fossa (gas has accumulated there); A. S., anterior superior spine; P. M., lumbar muscles.





that the ileo-cæcal valve is always continent. Tests on the cadaver showed that extreme pressure, beyond what would be possible in the living subject, is necessary to force it open.

*Intestinal Obstruction.*—Rudis-Jicinsky<sup>1</sup> reports two such cases: one, a boy of 10, swallowed a tin whistle, and the usual symptoms of intestinal obstruction followed. The site of the occlusion could not be determined in the usual way. On X-ray examination, the whistle was found at the junction of the small and large intestine. On the third day the whistle was passed. A boy, of 12, had symptoms of obstruction and was in a serious condition. The first diagnosis was one of invagination at the lower portion of the ileum. On X-ray examination an obstruction was found in the small intestine under the umbilicus. Laparotomy was performed, and the obstruction was discovered to be caused by a small wooden whistle. The author has produced artificial obstruction in dogs, and then traced a specially prepared pill to the point of obstruction by means of the X-rays. The diagnosis in such cases was verified.

I believe that the exact location of the obstruction or of a particular portion of the intestine cannot be determined because of the superimposition of the coils of the intestines; but an approximate location in the abdominal cavity can be ascertained by the direction of the passage traversed by a specially prepared opaque pill.

An important case coming under my care was that of a man, 42 years old, suffering with symptoms of intestinal obstruction. An X-ray examination was conducted, revealing a large-sized enterolith. The seat of obstruction was at the ileo-cæcal valve. An operation was performed and the obstructing mass removed. Three years prior to this, the patient had been a sufferer from biliary calculi, but refused to undergo an operation at that time. It is very likely that this intestinal calculus was primarily a biliary calculus which passed into the intestines and there remained for a period of three years, gradually becoming larger and larger. The exterior of this stone was uniformly softened, while the centre was extremely dense.

Following a biliary colic, it is always advisable to ascertain, by an X-ray examination, if calculi have been passed into the intestinal tract.

*Rectal Imperforation.*—The following case is illustrative of this condition. A child when born was observed to have an imperforate anus, with an absence of rectal tract. A consulting surgeon suggested an inguinal colostomy. The child lived with this annoying condition for twelve years. It was then decided to try further surgical means. I proceeded to examine the case, as follows: Into the rectum through the artificial anus, I injected an emulsion of bismuth subnitrate, at the same time passing a steel sound through the anus to the point of obstruction at the lower end of the rectum. A skiagram proved the obstruction to

<sup>1</sup> Medical News, Oct. 5, 1901.

be two inches in length. The upper part of the rectum was anastomosed to the ileum, after first removing the coccyx. For ten subsequent days the fecal material passed through the newly constructed channel.<sup>1</sup>

*Abdominal New Growths.*—The recognition of neoplasms located in the abdominal cavity, by means of the X-rays, is a rather difficult task. If the tumor is dense, it may cast a shadow upon the screen: if more or less soft, no shadow will be cast. These pathological masses are frequently recognized by their effects upon adjacent structures, as in a displacement of the diaphragm, liver, etc. I have made numerous examinations of suspected carcinomata of the stomach, some of the results being favorable, though the vast majority proved unsatisfactory. It must not be forgotten that in carcinomata of the pylorus there is some interference with the movement of the diaphragm on that side, the latter not descending to so low a point as in the normal.

#### E. LIVER.

The correct general outline of the liver may be obtained by combining a fluoroscopical and physical examination. The upper or convex border of this organ can very readily be ascertained by the fluorescent screen, while the lower and concave border is best outlined by palpation and percussion. Echinococcus cysts, when located in the immediate vicinity of the upper border, may be easily diagnosed by this means. When examining this organ, it is always advisable to have the adjacent portion of the stomach and intestines filled with air or gas, so as to more readily define the lower border of the liver. A skiagraphic examination, especially in adult cases, is very unsatisfactory. In young children better results are obtained.

*Biliary Calculi.*—The results of a skiagraphic examination in this condition depend to a very large extent upon the chemical composition of the calculus. Upon the negative, only a very light shadow of the stone is thrown and can, by a very careful examination, be seen only with difficulty, even though it is of rather large size. Occasionally large calculi can even be detected in the hepatic duct. Calculi composed of bilirubin and certain other substances are not very permeable to the rays. Those calculi consisting of cholesterin, being largely composed of calcium salts, show more distinctly on the negative than do the others. Early experiments upon gall-stones have been reported by Neisser, Goodspeed, and Cattell.<sup>2</sup>

A fluoroscopic examination for biliary calculi is thoroughly unsatisfactory, and until a skiagram is taken no absolute diagnosis should be rendered. The method I employ is as follows: The patient rests upon the table (upon his back) with the head-end raised and the foot-end

<sup>1</sup> For full report of this case see Hemmeter, "Diseases of the Intestines," vol. ii.

<sup>2</sup> Medical News, Feb. 15, 1896.



depressed, the whole top of the table slanting in a position of  $45^{\circ}$ . The abdomen should be bared of clothing and lightly bandaged, in order to lessen the peristaltic and respiratory movements. The patient is slightly turned toward the right side. A sensitive plate of proper dimensions is firmly fixed by a clamp and bracket to a stand in front of the affected region. A tube of the highest penetrative power is placed under the table, with the target pointing in the direction of the gall-bladder, or the patient may be placed in the ventral position with the tube above. The shoulders should be elevated, so as to bring the shadow of the gall-bladder outside of the shadow of the lower lobe of the liver. The time of exposure varies, depending upon the thickness of the part to be traversed by the rays.

The presence of calculi is very difficult to detect, because their chemical composition allows the passage of the rays, they being largely composed of the hydrocarbon cholesterolin. Moreover, the shadow of the calculus is very liable to be obscured by the shadow of the contents of the gall-bladder. When the stone finds its way into the intestine and there becomes coated with calcium phosphate and carbonate, the shadow cast will be more definite, as the latter salts offer a resistance to the passage of the rays.

Dr. C. Thurston Holland<sup>1</sup> reports the following case: "A woman, of 45, had two attacks of severe abdominal pain, one accompanied by slight jaundice. A tumor was discovered in the right abdomen and diagnosed as a distended gall-bladder.

"The radiograph was taken with a 12-inch coil and a mercury break. Current employed was 24 volts and 10 amperes. A Cox regulator tube was used with a spark-gap of 3 inches (7.5 cm.) and through a pressure-tube apparatus designed by the author. An exposure of two minutes was given. The stones, each three-quarters inch (2 cm.) long, were lying end to end, from before backward, and cast annular shadows with the patient lying with the abdomen downward on the plate. A second radiograph, taken with the woman on her back, also showed the same annular shadow, but, the stones being further from the plate, the shadow was larger and not so well defined. A surgical operation disclosed two stones of the usual type; one weighed 100 grains (6.4 grams), the other 113 grains (7 grams), which were composed of concentric laminæ of bile-pigment and cholesterolin. Calcium was present, but greater in quantity at the periphery, where the stones were much harder.

"The success attained in this case was due to the presence of lime-salts, and to the employment of a pressure-tube apparatus which fixed the part and cut off all except a small central stream of X-rays, and most of the secondary rays, and thus prevented fogging of the plate and blurring of the shadows."

<sup>1</sup> Archives of the Röntgen Ray, Feb. 1906, p. 241.

Dr. Carl Beck<sup>1</sup> made 97 skiagraphs of 28 suspected cases of cholelithiasis; in 19 of those cases the presence of biliary calculi was ascertained by operation. In only two of these 19 cases was he able to obtain shadows on the plates. Later, had good skiagraphs of gall-stones exhibited at a meeting of the Academy of New York, held in January, 1901.

For cutting off the secondary rays I think the compression diaphragm is at times useful. I have had cases where the plates showed shadows of the distended gall-bladder, but not of the calculi, because fluid offers great resistance to the passage of the rays. In most instances the shadow will be too low when the calculi have passed into the intestine.

Recently, at the Philadelphia Hospital, I was asked to take a skiagraph of a very emaciated patient. I found the shadows of two renal calculi in the left kidney, and a round, small stone under the twelfth rib, on the right side, and a large one in the pelvis of the right kidney. The latter was subsequently removed, but the former defied surgical detection; although I am sure the round shadow was that of a biliary calculus.

I do not think the fluoroscope is as reliable in these cases as is the skiagraph, provided that in the latter the time of exposure is correct and the subject is a suitable one. I never have had a case of this kind where the diagnosis was solely made by the aid of X-rays and confirmed by operation.

#### F. PANCREAS.

On account of its peculiar anatomical situation, this organ cannot be easily recognized by an X-ray examination. In one instance I was able to obtain a shadow of this organ on a skiagram. The patient was unusually emaciated, and from the clinical signs and symptoms, a diagnosis of carcinoma of the pancreas had been made. The patient was prepared as usual, and subjected first to a fluoroscopic and then to a skiagraphic examination; a very faint shadow was discoverable, superimposed upon the one produced by the stomach. Since then, I have at frequent intervals tried to make similar examinations on different subjects, but have never succeeded in repeating or reproducing what then was considered a rather satisfactory image of this organ. In this instance I distended the stomach with air in order to allow as clear a field for this organ as possible. I am of the opinion that this fairly good result was due to a peculiar abnormal principle which is opaque to the rays, and whose nature thus far has not been determined.

#### G. SPLEEN.

This organ is easily shown in children by means of the fluorescent screen. In adults the skiagraph only is satisfactory. The patient is best examined in the recumbent position, being slightly turned toward the left

<sup>1</sup>New York Medical Journal, January 20, 1900.

side. The sensitive plate is placed in front of the patient in the region of this organ, with the tube below or behind. In those who are corpulent, it is best to place the patient in the prone position with the plate beneath and the tube above.

Just prior to the examination, the large intestine should be distended with air. This procedure will serve to displace all of the adjacent organs, and at the same time permit the production of contrast between the lower edge of the spleen and the neighboring light area produced by these distended organs. The upper border is in relation with the diaphragm, and, in order to avoid the blurring of the image, the rays should be permitted to emanate from the tube only during intervals when the patient has ceased breathing. The screen examination of the spleen in a child demonstrates the fact that the anterior border moves slightly more than the posterior, as though this organ were turning on its long axis.

## II. Genito-Urinary System.

The great strides made in surgery and surgical bacteriology within the past twenty years have effected a complete change in the conceptions, the prognoses, and the treatment of many surgical affections. Nevertheless, prior to Röntgen's discovery positive diagnoses of many diseased conditions were manifestly impossible. The truth of this statement gains added support in the genito-urinary field. Many of the pathological states of the kidney could be ascertained only by cutting down upon that organ, especially in suspected cases of calculi, displaced kidney, hydronephrosis, pyonephrosis, etc., frequently forcing upon the surgeon the serious embarrassment of operating upon some distant organ, wherein pain was experienced by the patient, the result of reflex irritation. In the same manner invaluable assistance has been lent by this new aid in the diagnoses, in many of the more obscure diseases and affections of the ureters, the bladder, and the prostate gland.

The shadows of the kidneys are most difficult to show on the negative. The upper portion of the right kidney presents an added obstacle in the superimposed shadow cast by the liver. The affection of the kidney most frequently brought to the attention of the skiagrapher is that of suspected calculus.

### A. ORDINARY METHODS.

It is common experience that a case of renal calculus will be evidenced by a few of the classical signs and symptoms which not infrequently confuse the mind of the diagnostician. Thus, Henry Morris, the eminent English surgeon, found renal calculi in two-thirds of his suspected cases. Brewer<sup>1</sup> mentions two instances where distinguished

<sup>1</sup>Annals of Surgery, May, 1901.



surgeons diagnosed stone in the kidney as cases of appendicitis. Bevan and Franks made the same error, the former suspected a case of appendicitis, and the latter ovarian disease. Jacobson<sup>1</sup> mentions at length the differential diagnosis between incipient spinal caries and renal calculi.

Prior to the discovery of the X-rays, the most advanced studies in kidney affections were due to ureteral catheterization, introduced by Howard A. Kelly, of Baltimore, and to Harris's invention of the segregator, for drawing off separate urines from each kidney. The chief clinical aids may be stated as follows :

General symptoms, chemical, macroscopic, and microscopic examinations of the urine with the addition of the centrifuge, percussion over the affected side, the ureteral catheter and sound, inspection of the bladder and ureteral orifices, and the segregator. With the possible exception of the actual finding of a stone in the urine, we are not absolutely convinced whether we are to deal with a nephritic calculus, if there is one or many, if it is in the ureter, or if one calculus is in the ureter and another in the kidney. If upon exploration only one stone is found, it is not conclusive evidence that others are not present, either in the ureter or some other part of the kidney.

#### B. PENETRABILITY OF CALCULI.

The most useful and accurate method thus far advanced for the detection of renal calculi is by means of the X-rays. Chapius and Chauvel,<sup>2</sup> in Paris, were the first investigators to study renal calculi by the aid of the X-rays. They mention that calculi, whose chemical structure is uric acid, urates, or phosphates, cast shadows slightly less opaque to the rays than do compact bones. As the kidney substance is not so easily penetrated by the rays as muscular tissue, it would be natural to infer that the negative would show a lighter shadow than the adjacent tissue which is more penetrable by the rays. Dr. Macintyre,<sup>3</sup> of Glasgow, also made early and successful investigations on renal calculi.

Dr. James Swain,<sup>4</sup> of Bristol, was the first to detect the different degrees of penetrability of different calculi. His method of investigation was as follows : On a sensitive plate he placed different calculi of the same dimensions, exposing them for periods of one, two, four, eight, and sixteen minutes. He early observed that "the more dense the object the deeper was the resulting shadow," and that the law first laid down by Röntgen was not true of different calculi. If tabulated

<sup>1</sup> British Medical Journal, January, 1900.

<sup>2</sup> Académie de Médecine, 21, iv., 1896.

<sup>3</sup> Lancet, July 11, 1896.

<sup>4</sup> Bristol Medico-Chirurgical Journal, March, 1897.

in the order of their highest specific gravity, their greatest permeability to the rays, and their greatest density of shadow, the results attained are as follows :

SPECIFIC GRAVITY.	PERMEABILITY TO THE RAYS.	DENSITY OF SHADOW.
1. Oxalate of calcium.	1. Biliary.	1. Oxalate of calcium.
2. Uric acid.	2. Uric acid.	2. Phosphatic.
3. Phosphatic.	3. Phosphatic.	3. Uric acid.
4. Biliary.	4. Calcium Oxalate.	4. Biliary.

Dr. Swain exposed one calculus of each type with a section of rib and a piece of kidney. An increased time of exposure produced a fainter shadow, so that at the end of the "sixteenth minute," the calcium oxalate and phosphatic calculi, with a faint trace of rib, showed on the negative. The conclusions reached from these experiments are that the shorter exposures are better than long exposures, also that calcium oxalate and the phosphatic calculi show most plainly.

If the exposures are too prolonged, the less dense calculi will produce no shadow. Likewise a calculus of uric acid gives a fainter shadow than the rib, and in an eight minute exposure much less of a shadow than that of a rib covered partially with kidney. Thus we conclude that a calculus of uric acid is difficult of detection.

The most accurate method is that advanced by Röntgen. The many errors made in the diagnosis or elimination of renal calculi were all due to a faulty technic, to an incorrect development of the plate, or to an erroneous interpretation of the negative. It is imperative to produce a skiagram that has detailed shadows of tissues less opaque than the least opaque calculus.

By means of the X-rays we are enabled to diagnose hypertrophy, atrophy, displacement, tumors, hydronephrosis, pyonephrosis, and perinephritic abscess. Hypertrophy is a condition which is always unilateral, and, by comparison with the kidney of the opposite side, is readily diagnosed. The above mentioned conditions, however, can only be demonstrated in those subjects not too corpulent, when the exposure has been sufficiently long, and when the exposed negative has been properly produced by the developing process. The margin of the hypertrophied kidney is clear and sharp. If this sharp margin is irregular in any of its part, the examiner has found a neoplasm springing from the cortical area. Atrophy of the kidney is more difficult of diagnosis. The most usual cause is the existence of a calculus.

Displacement of the kidney is a common affection, its occurrence being indicated by a knowledge of its normal relations and by a comparison with the shadow produced by the abnormal position. Perinephritic abscess can also be diagnosed by the rays. The conditions favorable for best results are found in patients of slight build, and when the intestinal canal has been thoroughly evacuated.

In hydronephrosis and pyonephrosis, a shadow showing involvement of the pelvis of the kidney may be observed. This condition is more readily diagnosticated from a good negative than is a perinephritic abscess.

Cases of gonorrhœa, with pus in the region of the kidney, have been diagnosed with the X-rays; the skiagram showing an irregular mass on the convex border of the shadow produced by the kidney, the shadow of which is denser than that obtained from the normal kidney itself.

### C. TECHNIC OF RENAL SKIAGRAPHY.

When renal calculi cannot be diagnosticated by skiagraphy, the chief causes will be found to be under- or over-exposure and improper development of the exposed plate, or because the tube lacks the necessary high penetrative power.

*Preparation of Patient.*—In taking a skiagram see that the patient is briskly purged, and that he abstains from all food for at least 24 hours prior to the time of exposure; in the interval, give him a high enema. The bladder should be emptied just before the time of taking the picture; if this be impossible he should be catheterized. The patient is placed in the recumbent posture, and the knees flexed, so that the normal lumbar curve will come in closer contact with the plate. Two plates of sufficient size to include both kidneys should be placed on top of one another, and protected by a celluloid cover, in order to prevent injury from excretions. The upper edge of the plate should correspond to the position of the tenth rib, and the lower edge to the superior part of the sacrum. This will include part of the ureters at the lower end of the plate. The tube should be of the highest penetrative power, so as to lessen the time of exposure. When both kidneys are to be skiagraphed the tube should be placed in the median line above the patient, and at a level corresponding to the position of the pelvis of the kidney.

If only one kidney is to be skiagraphed, use a smaller plate, placing the tube in front of the patient, with the target pointing to the centre of the kidney. As respiratory movements interfere with the production of an accurate skiagram, the whole abdomen should be bandaged as tightly as possible. Some examiners prefer the patient holding his breath during exposure, but I have encountered some difficulties in attempting to carry out this method. For skiagraphing the renal organs, I always use the Wehnelt interrupter.

C. C. Slaberia and A. P. Slaberia,<sup>1</sup> of Barcelona, recommend the use of a moderately hard tube (except in cases of very stout patients, when a hard tube should be employed) and a long exposure, varying from three to six minutes in children, as much as thirty minutes in adults, and up to sixty-five minutes in very stout persons. They do not employ an

<sup>1</sup> Fortschritte a. d. Geb. der Röntgenstrahlen, Band v., Hefte 2, 3.



electrolytic break, nor have they seen any erythema or other injurious effects, although in one instance the patient was skiagraphed seven times. Except in the case of a displaced or very movable kidney, they advise the dorsal position of the patient. Despite some advantages, they consider the ventral position inadvisable because of the increased distance of the kidney from the plate. Dr. Charles L. Leonard, of this city, was the first to advocate a low-vacuum tube, with a spark-gap of  $1\frac{1}{2}$  to 2 inches, (4-5 cm.) which is self regulating, and which will give a large volume of low-vacuum Röntgen discharge. He formulates this axiom, "that in a negative possessing a differentiation in the shadow of tissues less dense than the least dense calculus, no calculus can escape detection." Personally I agree with Shenton and those other skiagraphers who advocate the high-vacuum tube with a short exposure. The latter is advantageous in taking negatives of suspected calculi, for these can be applied while the patient "holds his breath," thus avoiding diaphragmatic movements. I always make several short exposures when skiagraphing this region. I believe there is less likelihood of penetrating the calculus with the high tube and short exposure, than with a softer tube and a longer exposure. I cannot advise the use of the intensifying screen, because of the granularity presented on the negative; neither do I recommend the compression diaphragm, as we do not know where to apply the latter, as it covers only a small area at a time, and thus prevents comparison between the abnormal and the corresponding normal part. Dr. Joseph F. Smith, in his paper "The Röntgen Ray Diagnosis of Renal Calculus,"<sup>1</sup> remarks:

"In 1899, Abbe collected from literature and tabulated twenty-five cases in which a positive diagnosis had been made by the X-ray and later confirmed by operation. To this list of twenty-five he added two cases of his own, making twenty-seven cases reported up to that time. These twenty-seven cases are arranged by years as follows: 1896. Macintyre, of Glasgow, reported the first skiagraph of a stone taken in the body. Swain, of Bristol, reported a case. 1897. Gurl, Nuremberg; Fenwick, England; Thyne, Australia. 1898. Bevan, Chicago; McArthur, Chicago; Lauenstein, Germany; Alsbury, Germany; Martin, England; Taylor, England; Fenwick, England; Leonard, Philadelphia, eight cases; McBurney, New York; Abbe, New York, two cases. 1899. Wagner, Germany, two cases."

Speaking upon the probable errors likely to arise in cases of nephritic calculi, Dr. Chas. L. Leonard, one of the greatest authorities on this subject in America, says:<sup>2</sup> "The absolute negative and positive diagnosis of calculous nephritis and ureteritis can be made with an error of less than 3 per cent. A statistical study of the 320 cases examined shows that calculi have been found in 93 cases, or a little less than a third of the cases examined. In many of the cases, in which a negative or

<sup>1</sup> Annals of Surgery, May, 1904.

<sup>2</sup> American Medicine, June 4, 1904.

exclusion diagnosis was rendered, the patients had such slight symptoms as to render the presence of calculi possible, but not probable. In 47 cases the symptoms demanded operative intervention, and in all but one the accuracy of a negative diagnosis was proved by the operation, and no calculi were found. In many of the cases of negative diagnosis in which there was no operation, the subsequent development of other conditions showed that the diagnosis had been correct. In three cases of negative diagnosis, small calculi, that had escaped detection, were subsequently passed. Thus, there has been a total error of but four cases in the negative diagnoses, one due to defective technic, and the others to inaccurate reading of the plates."

Bevan<sup>1</sup> published a paper in the *Annals of Surgery*, reporting 13 or 14 cases, and claimed that the X-ray as a means of diagnosis was to be relied on to a greater extent in cases of kidney stone than any other means at our disposal. He thinks the best exposition of this entire work is to be found in "Beiträge für Chirurgie," from the pens of Kummel and Rumpel. Kummel takes the position of Leonard and Bevan, and presents practically these conclusions, that the X-ray, properly used, will detect a stone in any individual, no matter how thick, or of what chemical composition; that the detection of the stone does not depend so much on its chemical composition or the thickness of the individual, as it does on the proper use of the X-rays.

Kummel and Rumpel<sup>2</sup> report a series of eighteen cases diagnosed positively by the X-rays, all of which were subsequently operated upon, and stone extracted. The conclusions drawn from their work are as follows:

"The exact diagnosis of kidney stone is to be made only by means of the Röntgen procedure.

"The presence of a kidney stone, whether located in the kidney substance, the calices, or in the ureter, will be demonstrated upon the plate in every case, by proper application of the Röntgen method.

"The negative result of the Röntgen method after repeated attempts allows of the exclusion of a calculus.

"The demonstration of a stone shadow upon the Röntgen plate is not dependent upon the size and chemical composition of the calculus, but singly and alone upon the technic of the Röntgen operator.

"A high degree of corpulence in the patient may render the demonstration of a calculus by the Röntgen method very difficult, but in general does not render it impossible.

"In every case of nephrolithiasis it is advisable to employ the functional methods of investigation, since they show us by combined application (a) whether a disturbance of the whole kidney function exists

<sup>1</sup> Journal of the American Medical Association, March, 1905, p. 1062.

<sup>2</sup> Beiträge für klin. Chirurg., 1903, Band xxxvii., Heft 2.

or not, (*b*) whether we have to deal with a double-sided stone formation or other coexisting kidney disorder, or whether in the already existing disorder only one kidney is involved.

“The result of the negative Röntgen investigation should be considered in connection with the condition of the clearness, concentration, and freezing-point of the urine obtained by means of the ureteral catheter.”

In the eighteen cases tabulated by Rumpel, two of the stones removed contained only triple phosphates. All the others consisted of mixtures in different proportions of calcium carbonate, calcium phosphate, calcium oxalate, and uric acid or urates. Five of the stones consisted largely of calcium oxalate, fourteen of calcium phosphate, and two of uric acid. Of the two stones consisting largely of uric acid, the composition of the first was a mixture of uric acid with calcium phosphate, and the second, a mixture of uric acid with calcium oxalate and phosphate.

Errors in skiagraphing calculi may be due to several causes,—great density of the parts, as in very stout persons, transparency of certain calculi, as of the uric acid type, diminutive size of the stone, faulty exposure, faulty development of plate, or any defect in the apparatus.

I am in accord with the view expressed by Dr. Charles L. Leonard, that a positive or negative diagnosis of a urinary calculus should be based upon the findings on the negative, as the calculus should always be detected, if the negative shows a shadow of the least dense tissues. On a good negative, the shadows of the following structures should be visible: Shadows of the lumbar muscles, the transverse processes of the vertebræ, and the twelve ribs.

#### D. URÉTERAL CALCULI.

These are difficult to skiagraph, as the shadows of the pelvic bones superimpose upon the shadow of the calculi in the lower portion of the ureter.

Of the 93 cases in which calculi were found, Leonard states that there were four in which calculi were present in the kidney and ureter of the same patient. Including these cases, 33 renal calculi were found and 64 ureteral.

Tenny<sup>1</sup> has been able to add 33 cases of ureteral calculus since the publication of the 101 cases collected by Schenck.<sup>2</sup> The location of these stones has been in a general way in one of three places, depending on the physiological narrowing of the ureter. The first point of narrowing is about 7 centimetres down, and has a diameter of 3.2 millimetres. The second is just above or below the brim of the pelvis, and has a diameter of 4 millimetres, and the third is at a point just above the bladder, and has a diameter of 2.5 millimetres. The number of stones in the series of

<sup>1</sup> Boston Medical and Surgical Journal, Feb. 4, 1904.

<sup>2</sup> Johns Hopkins Hospital Reports, vol. 10.



34 cases caught in the above locations corresponds very nicely in its diameters, 35 being caught in the first isthmus, 18 in the second, and 73 in the third. In the remaining cases, the locations were not given.

On the left side of the ureter, but sometimes on the right, is occasionally noted a sharp, round, white shadow corresponding to the lower

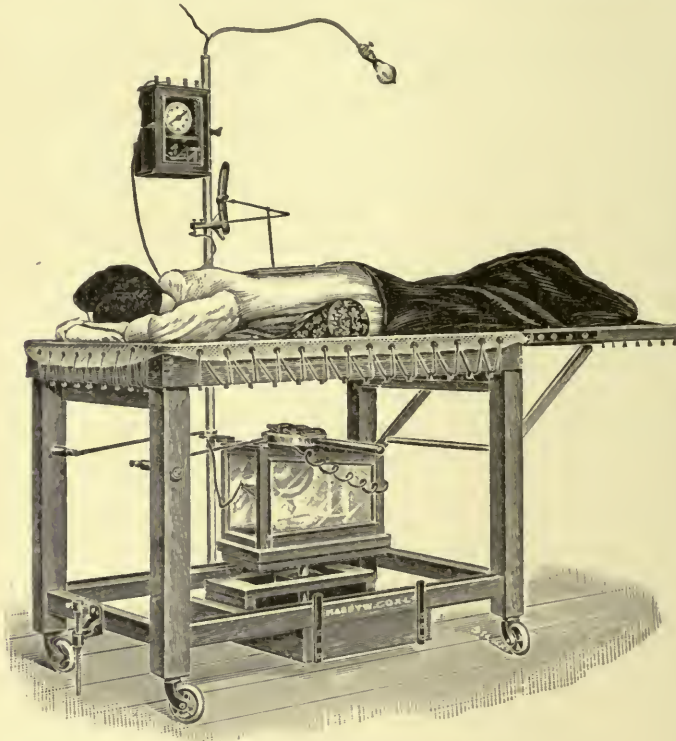

FIG. 190.—Reid's apparatus for renal skiagraphy.

end of the ureter. This is caused by the presence of a phlebolith, which must not be mistaken for a calculus. Dr. Russell H. Boggs, of Pittsburg, maintains that this shadow is due to a sesamoid bone.

E. W. H. Shenton,<sup>1</sup> of London, believes that the fluoroscope is not sufficiently used in examinations for renal calculi. He advises placing the patient in a horizontal position, face downward, with the arms above the head. Efforts should be made to make the lumbar spine straight, even to the extent of placing a pillow beneath the abdomen. The tube should be placed beneath the patient 6 inches (15 cm.) from the abdomen, the actual distance varying according to the conditions of the tube and the size of the patient. The screen is placed upon the patient's back.

A new apparatus for skiagraphing the renal region, devised by Mr.

<sup>1</sup>Archives of the Röntgen Ray, March, 1902.

A. D. Reid, of London (Figs. 190 and 191), and manufactured by Harry W. Cox, Ltd., of London, dispenses with the use of compressors and is described as follows: The patient is laid upon the couch and an air cushion is placed under the part to be radiographed. The plate is then placed on the patient's back and the lead base with the upright arm is attached to it. When the patient breathes the lead base is raised, the arm moves the lever up and causes it to make contact.

This contact is merely a switch introduced into the primary circuit of the coil, and consequently when it is closed the current is enabled to pass, and the tube fluoresces, simultaneously the clock shown in the illustrations records the length of the exposure.

It is, therefore, obvious that the kidney—or any other part of the body—must always be in the same position whenever the tube fluoresces.

Dr. Albers-Schönberg believes that the technic in renal skiagraphy has not been sufficiently studied. Hard tubes, he argues, should not be used. The shadows thrown by the last ribs and the transverse process of the first lumbar vertebræ are to be taken as guides. If nothing is

seen at the first attempt, it should not be concluded that the result is negative. The plate should be intensified, and allowed to dry. This brings out many shadow details, previously invisible. To obtain the best effects the plate should be examined at a distance of 5 or 6 ft. If any specks are seen, which may possibly be due to calculi, another exposure should be made within three or four days. In any case of doubt a separate exposure should be made. A lead pipe with an opening of 13 cm. in diameter is placed close to the tube, and 50 cm. from the plate, so as to cut off the secondary rays and obtain a well-defined shadow. (Figs. 192 and 193.) My time of exposure in renal skiagraphy depends upon the corpulence of the patient, and the degree of high penetrative power of the tube. The distance of the target from the plate is from 22 to 30 inches (55 to 75 cm.).

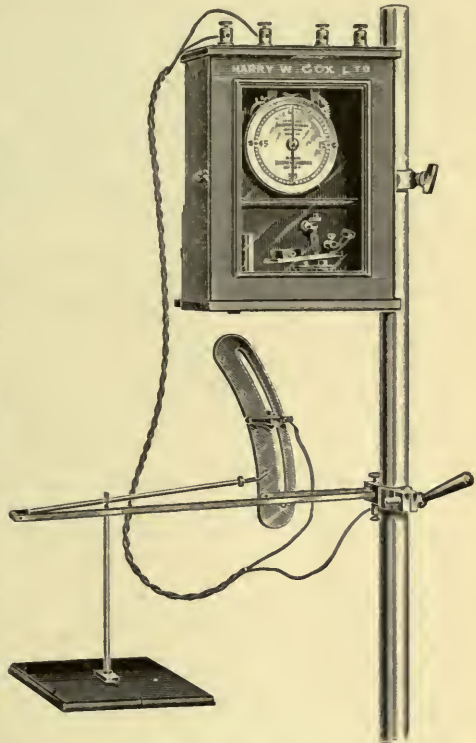

FIG. 191.—Clock arrangement and break of the same.

The method of examination of the kidney by the X-rays, when the organ is outside of the body during operation, has been fully described by the discoverer, Mr. Fenwick.<sup>1</sup> It consists in examining the kidney with the fluorescent screen after the organ has been removed as far as possible from the abdominal cavity. In some cases, he says, the kidney cannot be displaced out far enough to permit of a screen examination, due to insufficient length of the renal vessels. An objection to this method of examination is that the surgeon must necessarily remain in darkness for at least ten or fifteen minutes before he will be able to successfully perform a screen examination.

F. Voelcker and A. Lichtenberg<sup>2</sup> describe a process of pyelography. The ureter is catheterized, and the instrument is advanced to the renal pelvis. A 5 per cent. solution of a silver salt is then slowly injected through the catheter.

There are individual variations in the amount of fluid which the pelvis will tolerate: in one instance 5 c. c. gave rise to colicky pains, in

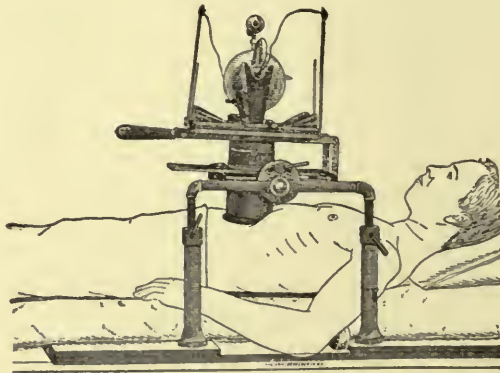

FIG. 192.—Compression diaphragm of Albers-Schönberg. (Kny-Scheerer Co.)

others 50 to 60 c. c. could be introduced. The shadow cast by the rays will reveal any abnormality, such as a kinking, bending, constriction, or dilatation of the ureter.

The authors employed the procedure in eleven cases, ten being women and one a man. In four of their cases, their efforts were unsuccessful. The operation is not very painful, but is more easily done after an injection of morphia.

I present the following as a few of my cases, showing the value of skiagraphy in determining the presence of nephritic calculi:

In the Medico-Chirurgical Hospital in 1901, I examined a case for Drs. Rodman and West, but found only an enlarged kidney. The

<sup>1</sup>The British Medical Journal, Oct. 16, 1897.

<sup>2</sup>Münc. med. Woch., January and October, 1906.



operation confirmed the diagnosis. In 1900, at the same hospital, I skiagraphed a case for Dr. Elwood R. Kirby, and, instead of a calculus, I found a collection of pus; this was subsequently confirmed at operation.

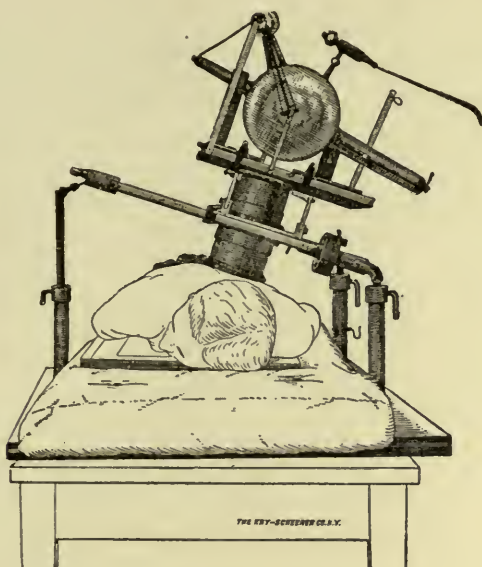

FIG. 193.—The same, postero-anterior view.

For several years I made an annual examination of a patient, under the care of Dr. Ernest Laplace. The negative showed a calculus in the pelvis of the kidney, which was subsequently removed. (Fig. 194.)

In a case under the care of Dr. Alfred Stengel, I found a calculus in the pelvis of the kidney, that for three years occasioned an unceasing dull pain. Dr. Charles H. Frazier removed the stone at the University Hospital.

At the Philadelphia Hospital in 1903, I skiagraphed a renal calculus for Dr. J. B. Carnet, which was successfully removed.

In 1904, at the same hospital, Dr. Ernest Laplace operated for a supposed case of appendicitis. After the operation the pain continued, and three weeks later a skiagram revealed a calculus in the kidney. This was removed, and the patient at once recovered.

#### E. THE BLADDER.

*Examination for Calculi.*—The preparation required is the same as for a renal examination, and in addition the bladder and rectum should be emptied just prior to the exposure. The patient should be placed upon the table in the ventral position. The plate, or preferably two,

well protected, should be laid under the pelvis. The table is tilted so that the head will be much lower than the feet, an expedient for bringing the calculus as much above the pubis as possible, thus avoiding superimposition of the shadows of the calculus and the bone. The tube is placed so that the rays will be parallel with the sacrum and pass through the true pelvis without causing any superimposition of the shadows on the negative. Skiagrams produced with the patient lying on the back have been very satisfactory in my experience, especially so in corpulent subjects, by placing the tube above the umbilicus.

In Fig. 195 is shown the skiagram of a large vesical calculus. At a prominent Philadelphia hospital, the case was incorrectly diagnosed as an enlargement of the prostate. The patient became progressively worse, and as a victim of neurasthenia, he applied to the Nervous Department of the Medico-Chirurgical Hospital, 1901. Dr. Ellwood R. Kirby suggested the wisdom of an X-ray examination, when the large calculus, here shown, was found. The patient was operated upon and made a perfect recovery.

Englisch<sup>1</sup> describes a total of 405 cases of calculi in the urethra or diverticulum. He classifies them in various groups, and discusses each in turn. The stones were in the membranous portion in 149 instances, and in the bulbous urethra in 68 cases.

*Closure of the Bladder, as shown Skiagraphically.* — Leedham-Green<sup>2</sup> found that, whether the bladder was fully distended or not, the outline of the organ was oval, not pyriform, and the urethra was sharply cut off from the bladder without a suggestion of a bladder neck. There are reasons, therefore, for believing that the sphincter of the bladder plays a more important part than Finger and Guyon credit it with, and that under ordinary circumstances it is by this muscle that the bladder is closed, whether distended or not.

#### F. PROSTATIC CALCULI.

F. Frank Lydston<sup>3</sup> reports that a farmer aged 34 was fallen upon by a horse, and the perineum sustained a severe blow. Hæmaturia followed, without obstruction of the urethra, and he was apparently well in 10 days. Six months later there was difficulty in micturition; he passed several small calculi, and has done so at intervals since. Examination revealed an apparent calculus at the bulbo-membranous junction, with enlargement of the prostate. Operation was advised, and through a perineal incision a calculus weighing 720 grains was removed from the prostate. Lydston believes that, as a consequence of the traumatic stricture, a certain quantity of residual urine continually remained in the canal,

<sup>1</sup> Arch. f. klin. Chir., Berlin, 1906, p. 743.

<sup>2</sup> Archives of the Röntgen Ray, May, 1906.

<sup>3</sup> Annals of Surgery, March, 1904.



FIG. 194.—Calculus in the pelvis of the right kidney. (Case of Dr. Laplace.)





FIG. 195.—Vesical calculus. (Case of Dr. Kirby.)

decomposition followed, with the formation of secondary calculi. The obstruction caused dilatation of the prostatic ducts, small secondary calculi were forced into the latter, and one of these became enlarged, forming a nucleus about which was deposited the material which resulted in the formation of the large stone. Stricture of the urethra may at times be detected by injecting bismuth solution and then taking a skiagraph. (For biliary calculi, see chapter on The Alimentary System.)

## CHAPTER VI

### APPLICATION IN THE SPECIALTIES.

#### I. Obstetrics and Gynæcology.

##### OBSTETRICS.

IN radiographing the uterus and its contents much difficulty is encountered, as in this part of the body the rays will have to penetrate many thicknesses of tissues; but, if the abdominal wall is not too fat, fair results may be expected. Another obstacle is, the refusal of the patient to remain in a constrained position for a sufficiently long time to obtain the desired results.

The distance of the sensitive plate from the uterus, the movements of the fœtus, and of the uterus itself, and the respiratory movements of the mother, are obstacles to satisfactory results.

*Pelvimetry.*— A new process of pelvimetry devised by Dr. Henri Varnier<sup>1</sup> demands brief attention. When a radiograph is to be obtained, the operator arranges the X-ray tube at a short distance from the part to be radiographed, usually varying from 16 to 24 inches (40 to 60 cm.). The result is that, since the radiographic negative registers only the projected shadows of the object, the image obtained is somewhat larger than the original, at least for all the parts of the latter not in direct contact with the sensitive plate.

In order to surmount this difficulty, Dr. Varnier removed his source of Röntgen rays to a distance sufficient to permit them to behave practically the same as if they were parallel. He has shown that the rays may come from a considerable distance and the ordinary double anode tubes can be employed.

With a coil of 10 inches (25 cm.) spark and provided with a Ducretet vibrator, he has been able, in an exposure of ten minutes and with a current of 10 amperes at 26 volts, to obtain the outlines of a dry pelvis upon a photographic plate placed at a distance of 25 metres from the Crookes tube, and in an exposure of 20 minutes the same outlines were obtained upon a plate 30 metres distant. It is usually better not to resort to such distances, thus obviating long exposures.

At a distance of five metres the usual instruments of measurement do not show any difference between the dimensions exhibited by the object and the radiograph. For ordinary exigencies a distance of 2.5 metres is sufficient, as shown in the following measurements by Dr. Varnier of a dry pelvis. The error found is of the same nature and

<sup>1</sup>Scientific American, May 1, 1901.



never exceeds 5 millimetres,—*i. e.*, it is practically *nil*. The *modus operandi* is extremely simple. The Crookes tube is placed at a distance of 2.5 metres (98 inches) from the plate, with its cathode perpendicular to the long axis of the upper brim of a normal pelvis, taken as a point of observation.

The following table was compiled by Dr. Varnier from experiments and measurements with a dry pelvis, and in it will be found the difference between the dimensions of the pelvis itself and the radiograph :

MEASUREMENTS MADE	DRY PELVIS		RADIOTYPE		DIFFERENCE	
	mm.	inches	mm.	inches	mm.	inch
Maximum transverse diameter.....	122	= 4.803	125	= 4.921	+3	= +0.118
Antero-posterior diameter (the only measure up to the present).....	114	= 4.488	117	= 4.606	+3	= +0.118
Left oblique diameter.....	118	= 4.645	121	= 4.763	+3	= +0.118
Transverse bi-ischiatic (the part farthest from the plate).....	103	= 4.055	108	= 4.251	+5	= +0.196
Width of the first piece of the coccyx.....	32	= 1.259	33	= 1.299	+1	= +0.040
Distance of the anterior and posterior iliac bones.....	235	= 9.281	235	= 9.251	+0	= + .0
Transverse diameter of the greater pelvis.....	250	= 9.842	250	= 9.842	+0	= + .0

Along the line A B (Fig. 196) taken as a base, he arranges in his frame a 40 x 50 centimetre (15.74 x 19.68 inch) sensitized plate. The dry pelvis is then placed in pronation (*i. e.*, with the front downward) with the line of crests resting upon C D and its antero-posterior diameter in line with E F.

In order to operate upon a living person, it suffices to replace the dry pelvis by the subject to be examined, who must lie so that the pelvis will assume the same position. By using the data given, the measurements may be accurately obtained.

The patient can be made more comfortable by employing the author's tube-holder and table, placing the tube under the table and having the patient assume the dorsal decubitus position; often the Trendelenburg position is useful, because of the gravitation of the abdominal contents toward the diaphragm, thereby lessening the obstruction to the rays.

Contremoulins,<sup>1</sup> of Paris, takes two skiagrams, with the tube in two

<sup>1</sup> Bouchard, "Traité Radiologie Médicale," p. 1010, a contributed article by M. Fabre.

different positions, without disturbing the patient or altering the plane of projection. The first negative is taken and then removed, and a

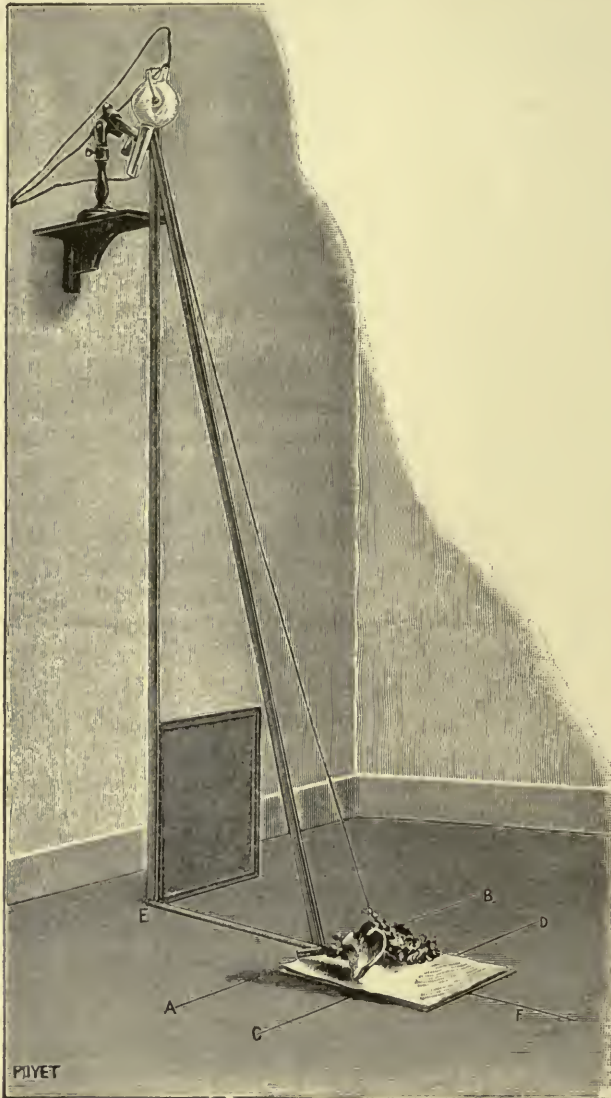

FIG. 196.—Varnier's arrangement for radiography.

second plate is placed in the same position. In each instance the normal point of incidence is indicated on the skiagram. A tracing of the salient points is made, to be ultimately transferred to a zinc plate. Threads are stretched from points in the latter by which the two cones of projection

may be redrawn, their apices corresponding to the two positions of the Crookes tube. The intersection of these cones is an index of the position and size of the pelvic inlet.

Stereo-skiagraphy of the pelvis is the best method to employ in pelvimetry and for the study of pelvic deformities.

The data given in the above table are those used in the special radiographic department of the Baudelocque clinic, founded by Prof. Pinard and Dr. Varnier.

Williams<sup>1</sup> says: "In order to determine the transverse diameter of the superior brim of the pelvis, the following method has been devised by me, by which the two halves of the pelvis are taken separately, but on the same photographic plate. The patient lies on her back on a stretcher, with the plate over the abdomen and the inlet of the pelvis about parallel with the plate. When the right side of the pelvis is being taken, the left half of the plate is shielded by a sheet of lead placed under the plate. The tube is placed by means of a plumb line as nearly as possible directly under the right border of the superior brim of the pelvis, in the line of the pelvic axis—3 centimetres to the right of the median line. If the tube is at least 60 cm. from the plate, the distortion in the photograph will not be great. After the first exposure has been made, and the left side of the pelvis is to be photographed, the sheet of lead is moved so as to cover the right half of the plate and the tube is placed immediately over the left edge of the superior outlet of the pelvis, 3 cm. to the left of the median line. Its proper position being obtained by means of the plumb line, the photographic plate is not disturbed. An exposure is then made of this part, and, thus, a photograph of the two sides of the brim of the pelvis is obtained. By this method the error due to the slanting direction of the rays falling on the pelvic brim and the plate when only one exposure is made for both sides is avoided, and no calculation is necessary to estimate the amount of exaggeration, as in the latter case." This method is applicable to non-pregnant cases. With the gravid uterus the plate cannot be brought in contact with the part.

A skiagraph of the fœtus may be produced quite readily after it has been taken from the uterus. In 1896 Dr. Oliver diagnosed one ectopic gestation, six weeks beyond term, in a woman aged 39 years. An attempt was made to radiograph the mass within the abdominal cavity, but the result was altogether unsuccessful. Operation proved the presence of an ovarian sac, which contained a nine-months' fœtus. After its removal by operation a successful skiagram of the fœtus was produced. Human fœtuses in various stages of development are to-day quite readily and successfully skiagraphed. The older the fœtus the better will be the resulting skiagraph.

<sup>1</sup>"The Röntgen Rays in Medicine and Surgery," p. 379.



*Gravid Uterus.*—I have been able to produce, in a few cases, skiagrams of gravid uteri. Dr. E. P. Davis<sup>1</sup> states, that his experiments showed that it is possible to obtain an outline of the living fetus in the body of the mother, notwithstanding the thickness of the tissues, and the distance at which the Crookes tube is necessarily placed from the fetus. I made several stereo-skiagrams of pregnant women at the Philadelphia Hospital for Dr. Davis, and the result was eminently successful.

Anatomical specimens of uteri, and their contents, removed from the body should occasion no difficulty. By varying the current and the time of exposure, it is undoubtedly possible to obtain a useful picture of the contents of the living womb.

Drs. Henri Varnier and Ed. Pinard have diligently studied the gravid uterus, both in the living and the dead, by means of the Röntgen rays. In the case of a woman dying from uræmia, they were enabled to

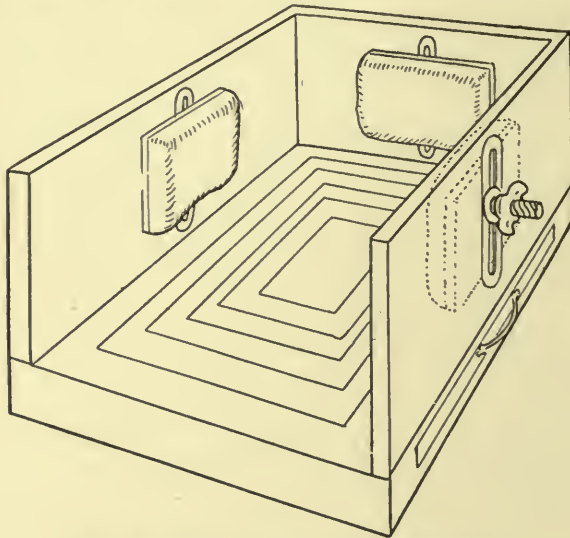

FIG. 197.—Author's head rest for stereoscopic work.

show the head of a seven-months' fetus at the superior strait. In the second case, after death from some form of lung disease, they were enabled to show the contour of the uterus, together with a part of the vertebral column of the contained fetus.

Queirel and Acquavita<sup>2</sup> assert that the evolution of the osseous system is demonstrable, at premature birth, by the skiagraph, and hence the determination of the age of the developing fetus assumes an importance in matters of medico-legal interest.

<sup>1</sup> American Journal of the Medical Sciences, March, 1896, p. 268.

<sup>2</sup> Bouchard, "Traité Radiologie Médicale," p. 1009.

## GYNÆCOLOGY.

So far the X-rays have been of little practical value in gynæcology. Before long, however, correct diagnoses of various tumors, cysts, abnormal positions of the uterus, diseases of tubes and ovaries, etc., will undoubtedly be made by means of the Röntgen rays. At present the shadows produced upon sensitive plates of the various conditions of the pelvic and abdominal organs (except the bladder and prostate) are insufficient in detail. Dr. Eden V. Delphey<sup>1</sup> says, that the main use of the X-rays in gynæcology lies in the treatment of malignant disease, and when a diagnosis is made sufficiently early, the neoplasm and often all the pelvic reproductive organs should be removed by surgical means, so as to get entirely beyond the malignant growth and prevent recurrence. When this can be done, the protuberant portion should be removed and the remainder subjected to the influence of the Röntgen rays.

## II. Rhinology, Laryngology, and Otology.

The X-rays are at present coming into use in affections of the nose, throat, and ear.

## RHINOLOGY.

A screen examination of the nasal bones, when displaced, depressed, or fractured, is well illustrated by this means. If supports, as silver or aluminium splints, are placed under the depressed bones, their correct position may easily be ascertained by a screen examination; the same holds good for exostoses and foreign bodies. Abscesses of the antrum and frontal sinuses may be readily skiagraphed, and I find for these cases head rests (Figs. 197 and 198) most valuable.

Diseases of the frontal sinuses may be skiagraphed in the occipito-frontal and lateral positions. The former is difficult, because of the thickness of the skull. By this view we note on the plate the presence or absence of these sinuses, also their size, shape, symmetry or asymmetry, the number of septa, the presence of contained morbid products, and the extent of the orbital and ethmoidal recesses. The skiagraph in the lateral position is easier of accomplishment, but it fails to show the details above mentioned, because only one side is taken and therefore forbids comparison; but it shows clearly the ethmoidal and orbital recesses and the sphenoidal sinuses. Both views should always be skiagraphed. The dentiascope, or endodioscope, first described by Dr. Macintyre and used for examining the hard and soft tissues about the bones of the face, nose, and larynx, deserves mention. Dr. Macintyre writes as follows:<sup>2</sup> "The fluorescent screen is placed inside of the mouth and the Crookes tube outside, or *vice versa*. Small disks of glass are coated with the fluorescent

<sup>1</sup> Annals of Gynæcology and Pediatrics, Feb., 1903.

<sup>2</sup> Glasgow Hospital Reports, 1898, p. 306.

salt and covered with aluminium, or tongue depressors consisting of flat strips of glass covered and coated in the same way may be employed. By placing the tube outside, I am able to get an image of the septum and other parts of the cavity of the nose, on the fluorescent screen in the mouth. In the same way the roots of the teeth may be seen. If the surgeon desires to examine the tissues externally,—*i. e.*, to pass the

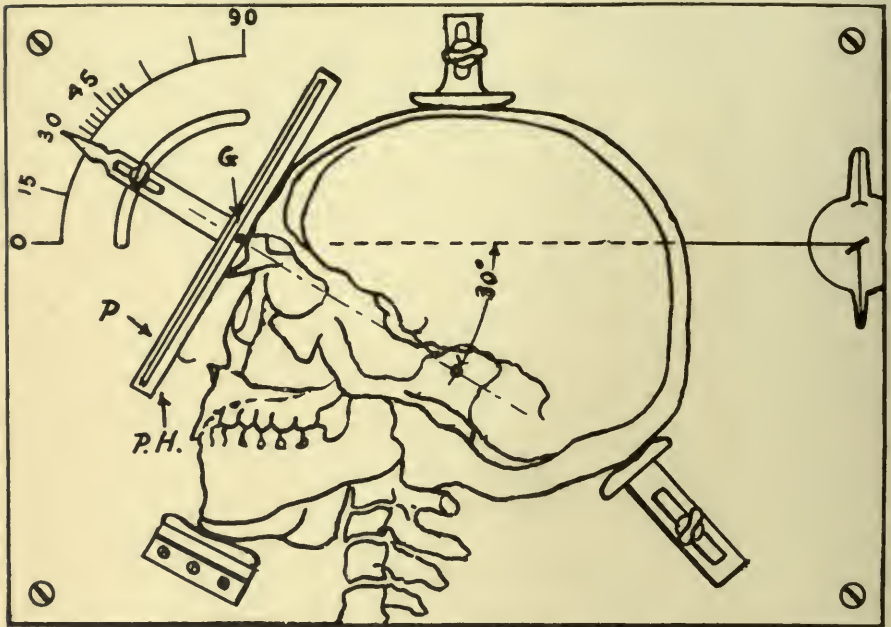

FIG. 198.—AUTHOR'S HEAD REST FOR SKIAGRAPHING DISEASES OF THE FRONTAL SINUSES.—With this device, the patient is seated and his head or face is applied to the board. There are two movable padded head rests, one on the vertex and the other under the occiput; the chin is supported on a rest. P. H. is a plate-holder lined with a transparent material, into which the sensitive plate can be slid or inserted. It is also very convenient for stereoscopic work. This plate-holder can be adjusted according to the angle of the face and forehead, as shown in the scale, and fastened at any angle. I find that a 30-degree angle is the best position for the patient. This angle is formed by the glabella G, the external auditory meatus, and the anode of the Crookes tube. As the facial angle varies in different individuals, it is necessary to adjust the tube accordingly. The more obtuse the facial angle, the more acute should be the angle between the bundles of rays and the base of the skull, or a line connecting the external auditory meatus and the glabella. The more acute the facial angle, the more obtuse should be the angle formed by the tube. The X-rays should form as near a right angle to the plate as possible, always avoiding the shadow of the occipital bone. If the rays are directed through the cervical region, the shadows of the vertebrae will throw irregular shadows over the sinuses. I find that this is unsatisfactory.

rays through the neck,—we can place a small fluorescent screen on one side and remove the Crookes tube to a suitable distance. By this means I have been able to demonstrate the presence of foreign bodies, and need hardly add that they are more easily photographed.”

Monnier<sup>1</sup> is able to diagnose the etiological factors of a chronic

<sup>1</sup> Archives Internat. de Laryngologie, November 3, 1898.



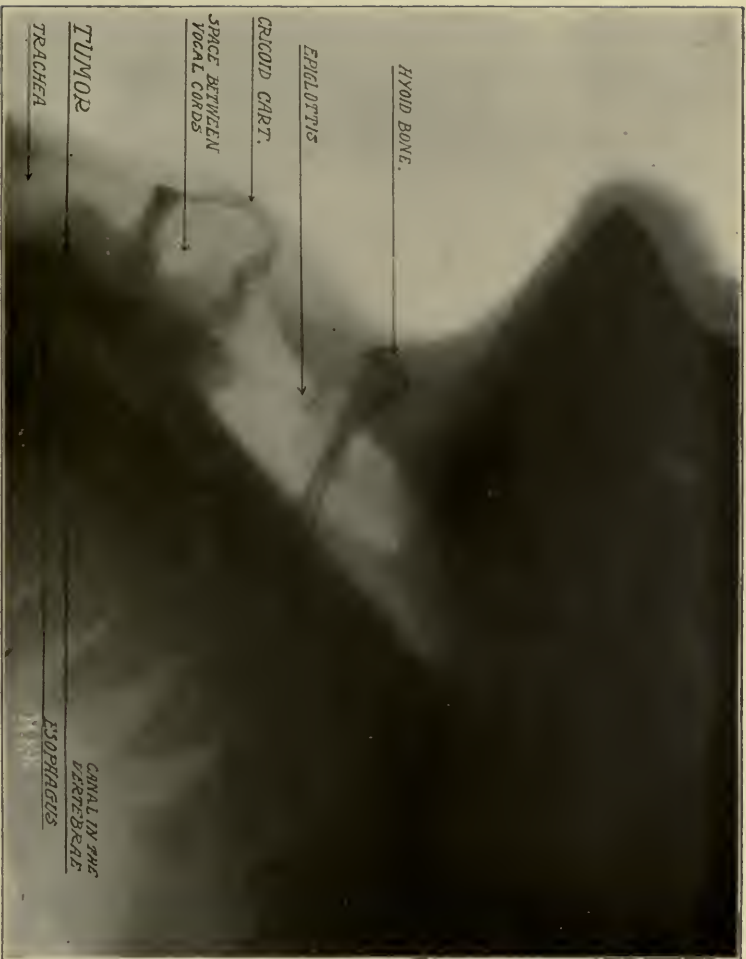

Fig. 199.—TUMOR IN THE TRACHEA.—Skigrammed with patient sitting on a chair, a five by seven plate laid against the trachea, head extended and bent a little toward one shoulder, in order that the rays might traverse the plates between the vocal cords. Fifteen-inch coil, electrolytic interrupter, tube of highest degree of vacuum located ten inches from plate, exposure one second. Metal-hydrocholine developer. It is usually thought that hard tubes are suitable only when penetration of dense structures is desired, and soft tubes for soft-tissue differentiation. I find that hard tubes are well adapted for soft-tissue skigrammy if the exposure is very short and the plate carefully developed.



post-nasal suppuration associated with epiphora. He gives as the cause a piece of a lacrymal sound which had remained in the nasal duct for some twenty years.

#### LARYNGOLOGY.

While the X-rays have accomplished but little in the department of laryngology, they have proved of great service in the detection and accurate localization of foreign bodies in the upper portion of the digestive and respiratory tracts, thus aiding the laryngologist to decide as to the advisability and character of operations for their removal; also in the determination of the ossification of structures in the laryngeal and tracheal cartilages. At present we can ascertain with scientific accuracy the time and the points at which all the cartilages ossify. The X-rays aid in the diagnosis of intra-thoracic growths involving the respiratory tract, either by compression of the trachea, or by some form of vocal-cord paralysis. They are also likely to prove useful in the earliest detection of any tuberculous processes in the lungs. The observer must be trained to this line of observation in order that perfection may be obtained. The delicate variations in the shadows that form on the fluorescent screen can be properly interpreted only by practice. Fig. 199 shows the presence of a tumor in the trachea.

#### OTOLOGY.

The rays have been of slight value in otology. In two cases where foreign bodies had been introduced into the ear, I was able to detect and localize them by means of the X-rays. In each instance the external auditory canal was greatly inflamed and swollen, so as to prevent an ordinary examination of the part with a satisfactory result.

The diagnosis of mastoid abscess by the X-rays is feasible. Three cases examined by me showed the presence of abscesses, and subsequent operations confirmed the diagnoses. In all these cases the negatives showed a dense shadow instead of the porous appearance found normally.



## CHAPTER VII

### APPLICATION IN DENTISTRY.

THE employment of the X-rays in dentistry has opened up a promising field.<sup>1</sup> Thus far skiagraphy has rendered invaluable aid, assisting the dental surgeon in diagnosing perplexing conditions and in confirming conclusions previously obtained. Thus, the position of the roots, the occurrence of fracture of a root, the presence of alveolar absorption, the existence of fluid in the antrum, and many other pathological states and conditions are readily revealed to us through this method of investigation. The structure and evolution of the teeth can be studied in the living subject.

#### I. Apparatus Used in Dental Skiagraphy.

The paraphernalia and technic employed in dental skiagraphy do not differ from those used for other regions of the body. A small coil of 6- or 7-inch spark length is sufficient. For the denser structures, as, for instance, the entire thickness of the maxillary bones, a tube of high vacuum is essential; the same kind of tube should be employed where the skiagram must be taken rapidly, and where the exposure is consequently short, as in cases of children.

#### II. Technic.

Fluoroscopic examinations in dentistry do not yield satisfactory results. The two methods at present employed in dental skiagraphy are the intra-oral and the extra-oral or buccal.

*The intra-oral method* consists in inserting a small piece of film (light and moisture proof) over the alveolar tissue where trouble is suspected, and in adjusting the tube so that perpendicular rays will fall upon the teeth and film. A small sensitive plate, being inflexible, cannot be made to adapt itself to the curvature of the part. Rollins, of Boston, encases the film in an aluminium cover, while Price, of Cleveland, Ohio, uses unvulcanized black dental rubber, protecting the emulsion with a sheet of sensitive bromide paper. Kodak films cannot be used for this

<sup>1</sup>The first skiagraph of the teeth was exhibited by Prof. Koenig, to the Society of Physics of Frankfurt-on-the-Main, in February, 1896.

In April, 1896, at the Congress of Erlangen, Walkoff demonstrated many skiagraphs of the teeth in living subjects. (Bouchard, "Traité Radiologie Médicale.")

Dr. William J. Morton on "The X-rays in Dentistry," which appeared in *Dental Cosmos*, June, 1896, reproduced from his book: "The X-rays, or Photography of the Invisible."

purpose. Formerly I preferred a specially prepared, thick, double-coated film, which I cut to the required size and enclosed in a layer of black paper, after which the paper was so folded as to enclose snugly the film, and the whole placed in a yellow envelope just large enough to accommodate the size of the paper and film; the smooth side corresponding to the sensitive side of the film. Lately I have much preferred Eastman's negative transparent films, which are neatly encased and always ready for use.

Place the patient in the dental chair and adjust the tube. See that the rays fall perpendicularly to the vertical axis of the teeth. If the adjustment of the tube is faulty, the shadows of the teeth will be distorted. In order to include, in the skiagraph, the roots of the teeth place the film against the hard palate. Before its introduction into the mouth, the enveloped film should be reinforced by a couple of rubber bands. Skiagraphic work on the superior maxillary bone is less satisfactory than upon the inferior maxillary, as the film cannot be brought in a line parallel with the teeth. Two films can be exposed at one time. As only one or two teeth can be included, the film should be pressed against the affected part, the exposure varying from two to ten seconds. By this method sharper definition on the negative is obtained, and only a small area is skiagraphed.

*The extra-oral or buccal method* (Fig. 200) requires a plate 8 x 10 to be brought in contact with the jaw at the suspected region. A block of wood is wedged between the widely extended jaws, and the patient is directed to lie upon the affected side, and to incline the head and neck to an angle of about 45 degrees. The tube is now placed on the opposite shoulder, the latter is protected by a sheet of lead (the tube being placed very close to the shoulder), and the rays are sent obliquely at a distance of 20 to 25 inches (50-63 cm.) from the face, to avoid overlapping of the shadows of the jaw. This method produces a picture of great area, and is intended for bicuspids and molars of both jaws. Exposure varies from half a minute to two minutes.

Dr. Sinclair Tousey,<sup>1</sup> of New York City, thus describes, "A new film-carrier and indicator for dental radiography with projection upon a horizontal plane."

"It consists of a stiff card two and one-half inches (6 cm.) wide and five inches (13 cm.) long, covered at one end by a sheet of rubber dam, which forms a pocket into which the film, wrapped in black paper, may be slipped. This end is placed horizontally in the patient's mouth, and held there, by tightly closing the lips and teeth. The part of the card which projects from the patient's mouth has a clamp of aluminium, which may be turned to either side or straight, and carries a thin aluminium rod which is always held at the proper angle to the plane of

<sup>1</sup> Archives of Physiological Therapy, September, 1905.

the film. Diagrams of the teeth are printed upon both the upper and lower surface of the card, and serve to indicate the position to which the aluminium pointer must be turned laterally.

“For radiographing the upper jaw the patient sits erect with a film-carrier in his mouth. The pointer is turned to the position on the diagram where the teeth of chief interest are located, and the X-ray tube in a Friedlander shield is brought into a position to correspond with the position of the pointer. In other words, we have an aluminium rod which points to the spot where the anticathode of the tube should be placed. For the lower jaw, a film-carrier is turned down, and it will often be found desirable to tilt the patient's head somewhat, in order to cause the indicator to point to a spot at which it is practicable to place the X-ray tube. It is hardly necessary to add that, since the incisor teeth are an inch behind the pivot of the indicator, the anticathode must be placed in corresponding relation to the pointer.

“The value of the film-carrier and indicator lies in the fact that it readily and securely holds the film in position, without placing the finger inside the patient's mouth. The proper relation of tube and film are very readily acquired. The picture obtained gives an exact measure of the length of the teeth, and, most important of all, the teeth of the whole side or front of the jaw may be shown on one film. By using an unusually wide film, it is practicable to secure a picture of very good definition, of the teeth of both sides of the lower jaw, and also of the incisor teeth, but the latter, of course, would be a confused overlapping mass. The radiograph of the upper jaw may show all the front teeth, or, if taken at the side, all the side teeth and the aurtrum of Highmore. To get the wisdom-teeth, either upper or lower, the back of the film must be held far back in the mouth, but this is less unpleasant to the patient than the more usual way of pressing a small film against the inside of the jaw far enough back for that purpose. The greater ease with which it is practicable to show the entire vertical width of the lower jaw is an additional advantage.”

### III. Clinical Applications.

*Unerupted Teeth.*—An important condition coming under the dentist's care is the retention or non-eruption of a permanent tooth, owing to the temporary tooth remaining in the alveolar socket, beyond the age considered normal. If the skiagram reveals the unerupted tooth to be of normal shape and so located as to permit of its eruption, the indication is to remove the temporary tooth. Many cases of odontalgia are undoubtedly due to an unerupted tooth; in such cases the etiological factor may be revealed by the X-rays. (Figs. 201, 202, 203, 204, 205, 206.)

*Necrosis of the Maxilla.*—Necrosis of the superior or inferior maxillary bone can readily be shown by careful X-ray examinations. (Fig. 207.)





FIG. 200.—EXTRA-ORAL METHOD IN DENTAL SKIAGRAPHY.—LS, lead screen for the protection of the operator. The arrows indicate the variable positions to which the author's tube-holder may be shifted. The illustration depicts the sensitive plate placed upon a book and the lad's left (suspected side) cheek resting on the plate, the dotted line shows the path of the rays.



FIG. 201.—UNERUPTED TEETH.—Malposition of the wisdom tooth in the lower right jaw and delayed eruption of the wisdom tooth in the right upper jaw, the latter indicated by dotted lines.



FIG. 202.—UNERUPTED UPPER CUSPID TOOTH.—The patient presented a swelling at the ala of the nose with reflex nasal and orbital symptoms. (Case of M. H. Cryer.)

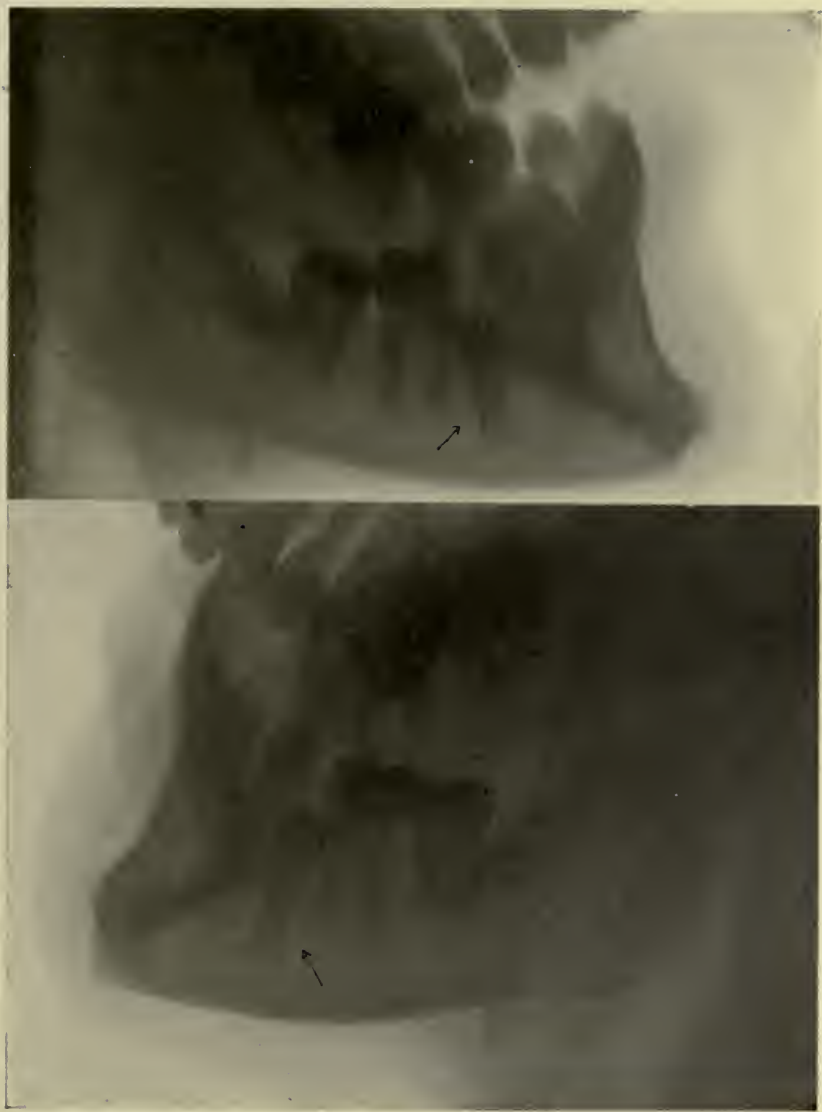



FIG. 203.—DELAYED ERUPTION OF THE UPPER CUSPID TOOTH.—The bridge is separating the first from the lateral teeth on each side.



FIG. 204.—DELAYED ERUPTION OF THE UPPER CUSPID TOOTH.—The temporary teeth are *in situ*. One of the latter was removed, when the permanent cuspid tooth was detected.



FIGS. 205, 206.—Delayed second bicuspids on both sides of the lower jaw, in a girl of 12. The upper picture is the right side of lower jaw, and the lower the left side of lower jaw. (Case of Drs. Cryer and Smith.)



FIG. 207.—PHOSPHOROUS NECROSIS OF THE INFERIOR MAXILLA.—Dotted area shows the portion of bone removed. (Case of Dr. Cryer.)



FIG. 208.—CHRONIC ALVEOLAR ABSCESS OF THE RIGHT CENTRAL INCISOR TOOTH.—Patient, age 18, treated for the above condition for a period of four years, having six sinuses on the labial surface of the gum. X-rays revealed remnants of foreign body at the apex of the root. Dr. C. F. Horgan removed the tooth (right central incisor), and, after cleaning and filling, the tooth was reimplanted. Two years later the patient remained absolutely well, and the tooth is giving good service.



A necrotic condition of the jaw, especially when advanced, as in phosphorus poisoning, gives the skiagram a lighter area than is produced by the adjacent unaffected bone. In a few cases that have come to my notice, I have observed a peculiar condition,—namely, an irregular arrangement of the teeth, failing to remain in the sockets, as seen normally. The light area produced by necrosis is undoubtedly due to a decrease of organic material, replaced partially by an increased amount of inorganic salts. In a case, referred to me by Dr. Cryer, the patient presented a swelling at the angle of the lower jaw. A skiagraph showed the absence of true osseous tissue. The part was curetted, and, three months later, at a clinic at the Philadelphia Hospital, the skiagram revealed a regeneration of the osseous tissue.

*Ankylosis of the Inferior Maxillary Articulation.*—This may be true or false, partial or complete, depending upon the cause. Fluoroscopic examinations in this condition are unsatisfactory, except for observing the movements of the temporo-maxillary articulation. The skiagram is taken by the extra-oral method. A negative showing the affected joint in the early stages usually presents an irregularity of the articulating cartilaginous surfaces. In true ankylosis, as when following a fracture involving a joint, the latter may be seen to be wholly obliterated. In false ankylosis, the joint is seen to be much eroded, the fibrous adhesions not being evident unless they have become partially infiltrated with inorganic salts.

*Fracture of the Inferior Maxillary Bone.*—For this injury employ the methods before described. In fracture of the symphysis, the plate should be placed under the chin, the inferior maxilla being fully extended, in order that the rays may penetrate the injured part from above. Some prefer to place within the oral cavity a film, and have the rays pass from the outside, as employed for unerupted teeth. The progress of repair in this fracture, as well as in others involving this bone, may be easily determined by frequent fluoroscopic examinations.

*Broken Instruments.*—Not infrequently a dentist, in his endeavor to fill the root canal, breaks an instrument, the fragment remaining inside the cavity. In his endeavor to remove the particle, he may cause it to become lodged more tightly and further up in the cavity. An X-ray examination will enable him to decide upon a course most suitable for its early removal.

*Root-Canal Fillings.*—An X-ray examination will demonstrate whether a canal has been properly filled or not. Such an examination after the filling of a root-canal would accomplish much toward the prevention of an alveolar abscess.

*Abscess of the Antrum.*—Pus or other fluid in the antrum of Highmore may readily be seen by careful fluoroscopic examinations. The X-rays are eminently practicable in diagnosing various diseases of the antrum. Foreign bodies, as roots of teeth, are located with exactness,

and the relations of the teeth to the antrum or abscesses about them may clearly be demonstrated, also the position and shape of the floor of the antrum, the presence of fluid or pus, etc., which may be contained therein.

*Alveolar Abscess.*—Dead pulp in a tooth indicates a break in the continuity of the pericemental membrane at the apex of the root, and more or less absorption of the adjacent osseous tissue, and occasionally of the roots in long-standing cases. In the majority of instances such an abscess is due to imperfect treatment, but in many cases the canal of the root is so narrow and irregular as to make it almost impossible to fill the canal or cavity to the apex. When a case presents symptoms of a pericemental inflammation and the history is uncertain, the most rational procedure is first to skiagraph the field, thus ascertaining the exact location and extent of the lesion and often its cause. (Fig. 208.)

Tumors, such as sarcomata or carcinomata, that frequently develop in the antrum, can in some cases be demonstrated by careful X-ray examinations. A cavity that is free from pus, blood, other fluid, or tumors shows a clearer and more sharply defined shadow than where one of the conditions just named is present.

*Orthodontia.*—In deformities of the jaws due to or associated with unerupted teeth, the dental skiagrapher can ascertain with great exactness the size, shape, and position of the teeth within the bones.

Occasionally the dentist is called upon to regulate teeth, and before so doing it is advisable for him to know the exact position of the roots, and also to what extent the tooth canals are closed. If the apex of the root is not fully developed, the teeth can be regulated more rapidly and without danger of destroying the pulp.

## CHAPTER VIII

### THE RÖNTGEN RAYS IN FORENSIC MEDICINE.

#### I. The Legal Status of the X-Ray.

##### A. ADMISSIBILITY IN VARIOUS STATES.

EVER since Prof. Röntgen's immortal discovery has been applied as a diagnostic agent in medicine and surgery, the legal status of the X-ray has been argued, denounced, and defended by attorneys the world over. It seems most fitting to quote a few lines from the comprehensive contribution of the Hon. W. W. Goodrich, Presiding Justice, Appellate Division of the Supreme Court of the State of New York,<sup>1</sup> second judicial department.

"The general rule with regard to ordinary photographs has long been that, wherever the person or thing would under general rules be relevant if produced in court, or the jury would be permitted to see it if convenient, a photograph of such person or thing, if properly authenticated, is admissible when the original cannot be seen. Whenever the jury are likely to be materially aided by the opinions, on matters of fact, of persons specially qualified, they should have them, and, for the purpose of illustrating and making clear the testimony of medical and surgical experts, photographs taken by the Röntgen or X-ray process have been admitted as evidence in the courts of several of the states. A reference to these cases will show the present status of the law upon the subject. The first case in which the question arose in this country is unreported, but there is a summary of it in the *Chicago Legal News*. It was decided in Colorado, in 1896, and, in admitting the X-ray photograph, the learned Judge Lefevre said: 'During the last decade at least, no science has made such mighty strides forward as surgery. It is eminently a scientific profession, alike interesting to the learned and unlearned. It makes use of all science and learning. It has been of inestimable value to mankind. It must not be said of the law that it is wedded to precedent; that it will not lend a helping hand. Rather, let the courts throw open the door to all well-considered scientific discoveries. Modern science has made it possible to look beneath the tissues of the human body, and has aided surgery in telling of the hidden mysteries. We believe it to be our duty in this case to be the first, if you please to so consider it, in admitting in evidence a process known and acknowledged as a determinate science.'"

Probably the leading case in this country on the subject under discussion is that of *Bruce vs. Beall* (99 Tenn. 303), decided September 30,

<sup>1</sup> Brooklyn Medical Journal, December, 1903.



1897. Judge Beard, writing for the Court, said: "In the progress of the trial, one Dr. Galtman was introduced as a witness, and he was permitted to submit to the jury an X-ray photograph, taken by him, showing the overlapping bones of one of the plaintiff's legs, at a point where it was broken by this fall. This was objected to by the defendant's counsel. This picture was taken by the witness, who was a physician and surgeon, not only familiar with fractures, but with the new and interesting process by which this particular impression was secured. He testified, that this photograph accurately represented the condition of the leg at the point of the fracture in question, and, as a fact, that by the aid of X-rays he was enabled to see the broken and overlapping bones with his own eyes, exactly as if, stripped of the skin and tissues, they were uncovered to the sight. We might, if we so desired, rest our conclusion on the general character of the exception taken to this testimony, but we prefer to place it on the ground that, verified as was this picture, it was altogether competent for the purpose for which it was offered. New as this process is, experiments made by scientific men, as shown by this record, have demonstrated its power to reveal to the natural eye the entire structure of the human body, and that its various parts can be photographed, as its exterior surface has been, and now is."

It is the opinion of some of the judges of Massachusetts, that X-ray photographs are not admissible as evidence, contending that as cold scientific truths they cannot be regarded as accurate. No one can positively attest to the absolute correctness of the reproduction. The truthfulness of the photograph is a matter of reasoning. In the Philadelphia courts, the skiagram is admitted as corroborative evidence, provided that it has been executed by an expert in the work; the same ruling is in force in the English courts. In Nebraska, the courts of final jurisdiction maintain that skiagrams must be taken by competent persons, who must be able authoritatively and indisputably to assert, that the appearances shown are accurate representations of the part.

In a malpractice suit, *Carlson vs. Benton*, in a Nebraska court, it was decided by the judge that a skiagram could be introduced as evidence, despite the fact that the skiagrapher was not experienced in this special field of work.

In this case, an X-ray photograph of an injured leg, taken after the injury had been treated by the defendant, was offered in evidence. The uncontradicted testimony of three surgeons left no room for a difference of opinion as to the accuracy of the photograph, the court maintaining that to exclude, under such circumstances, the skiagram as evidence, on the ground that a sufficient foundation had not been laid, was an abuse of discretion.

In medico-legal cases the X-rays are of inestimable value to the physician or surgeon in sustaining a diagnosis, to the patient who is instituting the suit, and, lastly, and probably most important, to the judge



and jury, to whom medical terms and expressions are often so wholly unintelligible. A skiagram of good "definition" can be fairly well interpreted by the average layman, and it will often assist an attorney in determining whether a case should be compromised or carried to court.

The courts are always disposed to permit an exposition of scientific methods that will elucidate the intricate questions submitted for judgment. In certain tribunals, where the skiagram is rigorously excluded, fluoroscopic examinations in the presence of the judge and jury are permitted, and the knowledge gained therefrom is counted as evidence.

The physician or surgeon (and this applies especially to the beginner) should always be guarded in expressing a positive opinion, as to the results that may be expected, after a difficult fracture, such as one involving the elbow, or the likelihood of the absence of deformity in a fractured clavicle, or the prevention of limping after fracture of the femur, etc. In any case where serious deformity and inconvenience may or may not result, that physician is wisest who ventures only the truth, explaining the probable results and informing the sufferer and his friends that he will do the very best he can under the circumstances. In those cases where one is quite sure of a correct diagnosis, and the plan of treatment is the one customarily followed, a prognosis may be given with a reasonable degree of certainty. All prognoses may be rendered slightly more favorable when the general condition of the patient is good and there is an absence of any complicating conditions.

In certain cases, the lines of treatment pursued may be perfectly proper, but if the patient is subject to the misfortune of having other maladies, as epileptic seizures, he may, by falling, cause a displacement of a properly reduced fracture, in which case the attending physician or surgeon is, of course, not held responsible.

#### B. TECHNIC OF MEDICO-LEGAL SKIAGRAPHY.

The technic in these cases demands special care, so that the negative shall be sharp and clear. It is not only advisable, but admissible in many of the courts, to have a detailed history of the case jotted down, the health of the patient prior to the injury, the time and the manner in which the accident occurred, and the method of treatment pursued; as well as the character and location of any marks on the patient's body, the length of time that they remained, etc.

The condition of the heart, lungs, and other organs after the accident must not be overlooked. First, the patient should be most carefully examined in a darkened room by means of a screen or fluoroscope, in such a manner that he and his attendants may not observe the result obtained by the examination. The examiner should never be alone when examining the patient, but should preferably have a physician or surgeon, or another X-ray expert, to verify the facts observed. The information

thus gained should remain secret. Following the fluoroscopic examination, a skiagram should be taken and developed later, so that a record of the injury may be preserved. Two plates should be placed one on top of another, so that two negatives may be had for future reference. Occasionally a plate is spoiled during developing, and the patient refuses to undergo a second examination; still the examiner has in his possession a good record of the case. The plate should always be placed in position in the presence of a witness, and it should have a mark upon it, such as a key, ring, or letters, so that the operator may be able to identify the part or side from which the negative was taken. The record should be kept in a book, together with the history of the case and a detailed account of the time of exposure, the distance of the tube, the number of amperes and voltage of current used, the kind of apparatus employed, etc. Negatives of the part should always be produced from directly opposite points of view, and, where possible, the injured and corresponding normal parts should be carefully skiagraphed for purposes of comparison. After developing the plate, no information regarding it should be imparted except to counsel or the attending physician.

The negatives should be prepared prior to going to court. To render them more intelligible to the judge and jury, the names of the bones seen, etc., should be written on them, whether right or left, lateral, antero-posterior, etc. An arrow, or other mark, should be on the negative, to elucidate the seat of fracture, dislocation, or other injury, and also the date of its taking. Under no circumstances should any other mark be placed on the negative.

The injured and corresponding uninjured parts should be printed and mounted side by side. The printing should be of equal and uniform density, and upon it may be written any points that may be of value to the judge, jury, etc., as, for instance, the diagnosis of the case in question. Occasionally a tracing upon the print is permitted by the lawyer for the defendant.

### C. HOW THE SKIAGRAPHER SHOULD PREPARE FOR COURT.

When the X-ray witness is called to court, it is important that he prepare himself thoroughly with the anatomy, physiology, and pathology of the part involved. He should hold a consultation with the medical or surgical expert who has employed his services. In this way a correct opinion of the case can be imparted. The skiagrapher should have with him the negatives and prints, the result of his X-ray examination, together with a set of bones of the part under consideration. When on the witness stand, he should be careful and accurate in his statements. In order that the jury may fully comprehend the statements uttered, his answers should be as free from medical terms and technicalities as possible. Answers should always be brief and to the point. The witness under cross-examination should not lose his temper; instead, he should

make every effort to remain calm and self-composed. Construct your answers according to the findings on the X-ray negative. If asked to answer questions irrelevant to the subject under discussion, or that do not relate to the findings on the negative, the skiagrapher should simply answer, "I don't know."

In our present knowledge there are many things that defy a correct interpretation on the negative, and we must frankly admit that fact.

When selected as an expert witness, the skiagrapher should direct the attorney employing his services, to inquire as to the technic, data, etc., employed in the production of the X-ray negative, and the physician who made the latter should be cross-examined, and not the attending surgeon. The subject of a differential diagnosis should always be brought forward.

The following are some of the claims made by plaintiffs:

That the physician or surgeon failed to properly diagnose the case. That the attendant delayed too long in the reduction of an unrecognized dislocation or fracture, thus seriously inconveniencing the patient and preventing his earning a livelihood. That by tardiness in, or total neglect of, reduction, temporary or permanent disability has resulted in a joint. That ankylosis, neuritis, or palsies have been caused by splint pressure, or that irreparable damage has been the outcome of callus formation in the distribution of an important nerve trunk. The foregoing claims may be prevented if the physician makes it a practice to have early and skilful skiagrams of his cases, if he gives guarded prognoses in all cases, and is careful and scientific in his methods of treatment. "If a physician or surgeon departs from the generally approved methods of practice, and the patient suffers an injury thereby, the medical practitioner will be held liable, no matter how honest his intentions or expectations were to benefit the patient" (Taylor).

The use of the X-rays is so universally commended in the modern works on surgery and medicine, that the surgeon who fails to apply them in doubtful cases, may justly be accused of negligent practice. In medico-legal cases, the X-ray diagnostician is likely to be asked the following questions:

1. Does the skiagram show fractures in all cases in which they exist? This question may be answered thus, not only will a fracture be shown in almost all cases, but the texture of the bone and the relative densities of the surrounding parts will also be shown, and any disturbance in the texture will be noticed. Rupture of ligaments, periosteum, and tendons, diseased conditions of the bones, etc., may also be observed, but cannot be excluded.

2. Does the skiagram show callus formation? Yes, it may be seen from the sixteenth day after the fracture, and up until the time of ossification, which may be as late as three months from the time of the accident. The duration of this callus formation varies, according to the age and health of the patient, whether the fracture is simple or



compound, its location, etc. When the bones are in perfect apposition, callus formation will be hastened. Massage will also facilitate its production. It will be seen from the foregoing that it is not always easy to predict how long it will be before callus will be strong enough to support the parts, but by skilful X-ray examinations the amount and density of the callus may be determined.

3. Another question often asked is, "Is the fracture united or not?" The answer to this question will depend upon the age, general health, local complications, and mode of treatment employed. By pressing upon the bones and at the same time viewing through the fluoroscope, we can tell definitely whether union is firm, and by means of the skiagraph we can tell the amount of callus.

4. In cases of deformity, we may be confronted by the question, "Was this deformity avoidable or not?" The avoidable cases are those resulting from an incorrect diagnosis on the part of the surgeon, or an improper line of treatment. The unavoidable cases are those of oblique fracture where the over-riding of the bones cannot be prevented; extra- or intra-capsular fracture of the head of the femur in the aged, where shortening is inevitable; in compound comminuted fractures, where it is necessary to wire the ends of the bones, resulting in shortening; and in intra-articular fractures often terminating in ankylosis of the joint.

Functional disability and the degree of visible deformity do not bear any definite relation to each other, as the deformity may be great, but the patient nevertheless have good use of the part, and *vice versa*.

It is sometimes necessary for purposes of identification to reveal the age of the patient or of the dead body, or to tell the age of a female child, as in cases of rape, etc.

Advantage is taken of the fact that the epiphyses of the various bones are known to ossify at different ages, and by making X-ray examinations of the bones, and knowing at what period ossification takes place, an approximate estimate of the age of the individual may be determined. The age of a fœtus can also be discovered by this means. The hydrostatic test for the determination of still-born infants may be corroborated by the X-rays, as the lungs will appear opaque if they have never been inflated, whereas if the infant has been viable for some time, they will present more transparency. As an evidence of the existence of death, the X-rays play an important part. After death, the pulsation of the heart is invisible and the organ presents a sharp outline. This will comfort those who are in constant terror of premature burial.

In February, 1899, Dr. J. William White, Chairman of the Medico-legal Committee of the American Surgical Association, sent a circular letter to each of the members asking replies to the following questions concerning the value and medico-legal relationship of the X-rays:

1. Have you found skiagraphy reliable in the diagnosis of (*a*) fractures attended with so much swelling of surrounding tissues that



satisfactory palpation of the fragments is impossible? (b) Fractures about joints? (c) Epiphyseal separations? (d) Fractures of the neck of the femur? (e) Ununited fractures? If, in any of the cases belonging to one or the other of these classes, the skiagraph was misleading, we would like particularly to have a print of it and the clinical history of the case.

2. Have you any reliable cases of recognition of (a) fracture of the base of the skull? (b) Fracture or dislocation of the vertebræ? (c) Fracture of the sternum, scapula, clavicle, or pelvis?

3. Do you know any of the cases in which the testimony of the skiagraph in cases of supposed foreign bodies in tissues, or of tumors, gall stones or kidney stones, has led to ineffective or mistaken operations?

The conclusions arrived at are succinctly stated as follows: "The routine employment of the X-rays in cases of fracture is not at present of sufficient definite advantage to justify the teaching that it should be used in every case. If the surgeon is in doubt as to his diagnosis, he should make use of this, as of every other available means, to add to his knowledge of the case, but even then he should not forget the grave possibilities of misinterpretation.

"There is evidence that in competent hands plates may be made that will fail to reveal the presence of existing fractures or will appear to show a fracture that does not exist.

"In the regions of the base of the skull, the spine, the pelvis, and the hips, the X-ray results have not as yet been thoroughly satisfactory, although good skiagraphs have been made of lesions in the last three localities. On account of the rarity of such skiagraphs of these parts, special caution should be observed, when they are affected, in basing upon X-ray testimony any important diagnosis or line of treatment.

"As to questions of deformity, skiagraphs alone, without expert surgical interpretation, are generally useless and frequently misleading. The appearance of deformity may be produced in any normal bone, and existing deformity may be grossly exaggerated.

"It is not possible to distinguish after recent fractures between cases in which perfectly satisfactory callus has formed and cases which will go on to non-union. Neither can fibrous union be distinguished from union by callus in which lime-salts have not yet been deposited. There is abundant evidence to show that the use of the X-rays in these cases should be regarded as merely the adjunct to other surgical methods, and that its testimony is especially fallible.

"The evidence as to X-ray burns seems to show that, in the majority of cases, they are easily and certainly preventable. The essential cause is still a matter of dispute. It seems not unlikely, when the strange susceptibilities due to idiosyncrasy are remembered, that in a small number of cases it may make a given individual especially liable to this form of injury.

“In the recognition of foreign bodies the skiagraph is of the very greatest value; in their localization it has occasionally failed. The mistakes recorded in the former case should easily have been avoided; in the latter they are becoming less and less frequent, and by the employment of accurate mathematical methods can probably in time be eliminated. In the meanwhile, however, the surgeon who bases an important operation on the localization of a foreign body buried in the tissues should remember the possibility of error that still exists.

“It has not seemed worth while to attempt a review of the situation from a strictly legal stand-point, as different states and different judges vary in their interpretation of the law. The evidence shows, however, that under many differing circumstances the skiagraph will undoubtedly be a factor in medico-legal cases.

“The technicalities of its production, the manipulation of the apparatus, etc., are already in the hands of specialists, and with that subject also it has not seemed worth while to deal. It is earnestly recommended that the surgeon should so familiarize himself with the appearance of skiagraphs, with their distortions, with the relative values of their shadows and outlines, as to be himself the judge of their teachings, and not depend upon the interpretation of others, who may lack the wide experience with surgical injury and disease necessary for the correct reading of these pictures.”<sup>1</sup>

With the exception of the statements that skiagrams of fracture of the base of the skull are unsatisfactory, and that the detection of callus formation and fibrous union in recent fractures is not always possible, there are few, if any, surgeons who to-day would endorse any such conclusions. More exact methods of study and interpretation of negatives, and greater refinements in the necessary technic have made X-ray examinations and applications invaluable aids in medicine and surgery. The very men who in 1899 ascribed doubtful value to the X-rays are to-day its staunchest supporters; indeed the judge and jury will frown upon a practitioner for negligence who has failed to avail himself of this most precise and scientific method in any case of doubtful diagnosis, where, through its agency, practical results might have been procured.

## II. The Physician's Responsibility in Cases of X-Ray Burns.

X-ray burns are divided into two great classes: Those produced during an examination for diagnostic purposes and those brought about by irradiation for therapeutics. Shortly after the discovery of the X-rays, the use of this agent in diagnosis was not infrequently followed by a dermatitis, the result of inadequate apparatus, fewer refinements in technic, and a limited experience in the application of the new agent. But in spite of these various factors, the most successful, the most skilled, and

<sup>1</sup>The American Journal of the Medical Sciences, July, 1900.



the most earnest student of the X-rays, with the best and most modern apparatus, is liable at times to produce a dermatitis, for who can say which of us are victims of idiosyncrasy, or who knows the exact nature, chemical and otherwise, of the X-rays?

When a patient applies for X-ray treatment, the skiagrapher should mention the possibility of a burn, and he should either administer the treatment himself or have it given under his direct supervision.

With idiosyncrasy and no exact measurement of dosage, the X-ray specialist who follows the established rules laid down by his confrères, and by experience, is taking the safest and the only rational course.

This subject is best treated of by a recital of the more important cases wherein damages have been asked by the complainant, urging carelessness, negligence, or incompetency upon the part of the radiologist.

In a suit against Dr. Samuel Lloyd, of the Post-Graduate Hospital, *the patient was warned of the danger of a burn*. Two radiographs were taken, when a diagnosis of appendicitis was made. Later the patient complained of an X-ray burn prior to the operation. The operation disclosed an appendicitis of an advanced type. The suit was to recover \$50,000 damages for the "burn." The contention of the defence was that the dermatitis from which the plaintiff suffered came from the antiseptic preparation for the operation for appendicitis, and not from the rays. The case, however, never came to trial.

In October, 1897, Dr. Frank Boyd<sup>1</sup> was made the defendant in a damage suit for producing a severe dermatitis with the rays, the plaintiff averring that carelessness was largely the cause of the dermatitis, as well as an insufficient understanding of the rays at that early period of their employment. The verdict rendered was in favor of the defendant, the court holding that in this, as in other cases, the physician was bound to use ordinary skill and judgment, placing the case upon the same footing as chloroform anæsthesia.

In the case of *Henslin vs. Wheaton*, the Supreme Court of Minnesota maintains that in an action for negligence and unskilfulness, the rule of liability is the same as that applied to other actions for malpractice, and one of ordinary care and prudence. Being the first case of its kind in Minnesota, the judge remarked that no rule of care in such cases had been laid down. But there can be no doubt that the rule applicable to the care and skill required of physicians toward their patients in other cases applies. That rule was stated in *Martin vs. Courtney*, 87 Minn. 197, in the following language: "The legal obligation of the physician to his patient, where his conduct is questioned in an action of this character, demands of him no more than the exercise of such reasonable care and skill as is usually given by physicians and surgeons in good standing."

The plaintiff testified that the exposure of his person to the rays was

<sup>1</sup> Journal of the American Medical Association, February 12, 1898.

for too long a period of time (30 to 40 minutes), and that the tube was placed too close to his body (two inches, except at one visit, when it was placed more distant).

The foundation was fully laid for the opinion of an expert touching the questions involved in the case. But the expert was not a physician and surgeon, and the defendant raised the objection that only one was qualified to testify against him, under the rule pronounced in the case of *Martin vs. Courtney*, 75 Minn. 255, where it was held that, in an action against a physician or surgeon for malpractice, unskillfulness in treatment being charged, the physician was entitled to have the propriety of his treatment tested by physicians of the same school. The trial court applied that rule to this case, but the Supreme Court was of the opinion that it erred, contending that the application of the rays to the complainant was not for the purpose of treating any disease or ailment from which he suffered, but for the location of a foreign substance, thought to be in his lungs (the gold crown of a tooth).

In the *Courtney* case, mentioned above, it was contended that the apparatus for the generation of the rays, likewise the fluoroscope, has been used very generally by electricians, physicists, skiagraphers, physicians, and others for experimental and demonstrative purposes. It is a scientific and mechanical appliance, the operation of which is the same in the hands of all. It may be applied by any person possessing the requisite knowledge, and there would seem to be no reason why its application to the human body may not be explained by any person who understands it. The rule in the *Courtney* case could therefore have no application to the case being tried. For in the latter, the rays were not applied as a remedial agent, but for the scientific purpose of discovering the presence of a foreign substance in the lungs. A physician, therefore, who applies the X-rays, not for medical purposes, but to locate a foreign substance, is not entitled to have the question of his care and skill determined only by the opinions of physicians of his own school.

A suit of unusual interest has lately been heard in the high courts. A child supposed to have run a needle into his knee received repeated X-ray examinations. No needle was discovered. A severe X-ray burn, resulting in an ulcer, appeared on the inner side of the knee, which took several months to heal. The examinations were made by a mechanic, under the supervision of a medical man who had not a practical knowledge of radiography. It appears also that he did not recognize the ulcer as an X-ray burn, but after its formation continued his examinations. Discovering the cause of the injury, the child's parents asked damages for alleged neglect on the part of the defendant. The trial lasted seven days. Assuming the truth of the statement of the child's relatives, that the tube had been held close to the knee for periods of a half hour, the experts on one side gave their opinion that such application showed negligence. On the other hand it was maintained that the tube never



came nearer the knee than eight or ten inches, and from the radiographs produced, it was held by experts that the distance of exposure must have been eight inches. The jury returned a verdict for the defendants on every count, finding that there was no negligence.

In the United States a suit was brought for \$25,000 damages against Dr. Otto Smith and Professor W. C. Fuchs, of Chicago.<sup>1</sup> The plaintiff, aged 37, broke his right ankle as the result of an accident on September 2, 1895. He was able to attend his business on May 1, 1896, and was then practically as well as ever. He only suffered from slight stiffness and occasional swelling in the ankle. On September 19, 1896, X-ray photographs were made, each sitting occupying from thirty-five to forty minutes, the tube being placed five or six inches from the ankle. While under the exposure the patient complained of sharp, tingling pains. Three days after, a slight redness appeared between the big toe and the adjoining one, which in three weeks had spread over almost the entire dorsum of the foot, later forming a blister. An intensely painful ulcer formed, for which condition amputation of the foot was performed. The jury awarded the plaintiff a verdict for \$10,000.

A rather remarkable case was that of a man named Shelly, who brought suit against Dr. G. W. Spohn, of Indiana, claiming \$10,000 damages for X-ray burns upon his face and left hand. The patient was treated for a cancerous growth on the under part of his tongue. He was warned of the possibility of a burn before the treatment was instituted. After two weeks a slight dermatitis developed on the patient's face, and the treatments were then discontinued. The patient claimed that the doctor directed him to hold down the lower jaw with his left hand during his treatment. It was proved on trial that the only real injury was to the hand, and this was shown to be caused by infection of a wound on the hand. The hand became infected because the patient persisted in wiping the saliva from his mouth, against the advice of his physician. The court decided in favor of the physician.<sup>2</sup>

It will be interesting to note briefly the views entertained and the verdicts rendered by European jurists. A few are subjoined.

Suit was instituted against "Dr. Sch." by a lady whom he treated for a beard-like growth on the chin.<sup>3</sup> A burn developed, involving not only the chin, but also the neck and part of the chest. A verdict for \$75 was found against the doctor. He appealed, to have a truly competent expert summoned to decide, naming Schiff or Freund, of Vienna. He also asserted that he was not responsible for the devastation caused by the burn, as it was treated by other physicians who applied ichthyol,

<sup>1</sup> A summary of the case appears in the American X-ray Journal, St. Louis, Mo., May, 1899, No. 5, p. 566.

<sup>2</sup> Medico-Legal Bulletin, January, 1903.

<sup>3</sup> Allg. med. Ct.-Ztg.

carbolic acid, etc., while experience has shown that strong measures are injurious in such cases, and that X-ray burns should be treated with exceptional mildness.

In France, a trial heard before the Civil Tribunal of the Seine, on March 8, 1901, resulted in heavy damages for injury following the application of the X-rays.<sup>1</sup> In delivering judgment the court found that Madame Macquaire suffered from osteitis of the femur, and was referred to Dr. Renault for an X-ray examination. Three exposures were made; the first lasted forty minutes, the second, which occurred eight days later, consumed forty-five minutes, and the third, which was given fifteen days subsequently, occupied a duration of one hour and a quarter. A slight erythema was noticed before the third sitting. The three exposures, which gave a negative diagnosis, were followed by a deep burn of the abdomen that necessitated treatment for two years. A scientific report of the case was presented to the court by Professor Brouardel, who stated that the operator's apparatus, which at one time was efficient, had outlived its usefulness, and that he had given too long an exposure.

The court, commenting upon the defective methods employed, observed that the defendant was called in not as a medical man, but as an electrical specialist, but that, nevertheless, his medical title had gained the confidence of his patients. A too long exposure was certainly one cause of the accident. The third exposure of an hour and a quarter was inexcusable, in view of the fact that the tissues had already been injured by a previous exposure a little over half that time. The conclusion of the court was that Dr. Renault had committed a grave professional error, and he was ordered to pay 5000 francs damages.

The suit against Professor Hoffa, of Berlin, the famous orthopedist, became widely known not only because of the prominence of the defendant, but more so for the complicated etiology of the injury.

The patient suffered from ankylosis of his hip, presumably after coxitis, for which he was treated by the Röntgen rays under the supervision of an X-ray specialist. Altogether he was exposed six times. No change for the better occurring, the patient consulted Professor Hoffa, who advised a diagnostic exposure in order to ascertain the condition of the hip-joint. The distance of the tube from the abdominal integument was 30 cm., the length of exposure twenty-five minutes. Ten days later extensive dermatitis set in, which caused the patient to bring charges of criminal negligence in the treatment. Professor Hoffa, in defence, claimed that the exposure was made according to the principles adopted by the medical profession, and that furthermore the sensitiveness of the skin was increased by the previous irradiations. The district attorney, after having called upon an expert, who sustained Professor Hoffa, dismissed the claim.

<sup>1</sup>Gazette des Tribunaux, March 9, 1901; and La Semaine Médicale, March 13, 1901, No. 6, p. xlii.



At present, by our greatly improved means, Hoffa would not have burned his patient, even in spite of the preceding irritation, because he would not have been exposed for twenty-five minutes.

We may safely expect that damage suits for Röntgen-ray burns, caused during diagnostic exposures, will become more and more infrequent. But with the employment of the rays for therapeutic purposes, burns have now become a rather common accident. In several instances suits were brought against physicians on the ground that they did not use the necessary means of protection; in most of these cases the severe character of the diseases demanded so severe a treatment that burning had to be contended with. This fact alone is sufficient proof of the perfidious nature of the suits. Where cosmetic considerations alone are concerned, such heroic therapy is injudicious.<sup>1</sup>

A man suffering much distress<sup>2</sup> in the early stage of locomotor ataxia was sent by his physician to a firm of chemists for treatment with the X-rays. The rays were applied ten or eleven times and the physician was never present. The man who administered the treatment often left the patient during the sitting. The machine emitted great sparks and once or twice gave the patient a shock, but being quite ignorant he made no complaint to his physician. His feet began to blister, for weeks he suffered greatly, and his screams were such that lodgers left the house. Eventually, the soles sloughed off and he became unable to walk. He brought an action for damages against the firm. Mr. Chisholm Williams, superintendent of the X-ray department of the West London Hospital, was called as a witness. He said that it was evident that the plaintiff had been placed too near the instrument—12 or 18 inches being the proper distance, not 2 or 3. In cross-examination he admitted that the use of the X-rays is a recent innovation, and that even physicians are burned at times. The plaintiff's physician said that he had never administered the rays, and that he had only studied the subject from books. He said that he thoroughly trusted the defendants, who had often administered the treatment for him, merely telling them the part to which the rays were to be applied. For the defence it was urged that the defendants were not liable for mistakes of the physician. Witnesses were called to show that it is essential that a physician should be present as well as the person who administers the treatment. The defendants stated that they had not studied the properties of the rays or administered them from a therapeutic point of view. The jury returned a verdict for the defendants.

*Medico-legal Aspect of X-ray Sterility.*—Destruction of the procreative capacity by means of applications of the Röntgen rays may perhaps

<sup>1</sup> Quoted from an interesting article on "The Medico-legal Aspect of Accidents caused by the Röntgen Rays," by Carl Beck, M.D., in *American Medicine*, April 16, 1904.

<sup>2</sup> *Journal American Medical Association*, August 10, 1906.

prove of frequent occurrence if the use of the apparatus by anybody and everybody continues to be permitted. The matter was brought up by M. Hennecart at the Röntgen Ray Congress recently held in Berlin.<sup>1</sup> He advocated legislation restricting to physicians the use of the rays on human beings, arguing that it would be difficult to punish laymen in the event of avoidable injury. He met with hearty support in his contention, and, on motion of Dr. Becher, of Berlin, a resolution was adopted calling upon physicians to employ only medical men in X-ray work, pending legislation on the subject.

A committee was recently appointed by the Paris Académie de Médecine to report on the question whether the medical use of the Röntgen rays should be restricted. They emphatically advocate that the medical application of the Röntgen rays should be legally restricted to duly qualified persons. Their conclusions are based on the established facts that the medical use of the Röntgen rays may lead to serious accidents, and that certain practices may prove a social danger, while, on the other hand, only qualified physicians or health officers, or regularly licensed dentists (in the domain of odontology), are capable of interpreting the results obtained from the point of view of the diagnosis and treatment of affections.<sup>2</sup>

<sup>1</sup> Presse médicale, May 13, 1905.

<sup>2</sup> Arch. d'Électricité médicale, February 10, 1906.



## PART III

### RADIOTHERAPY, RADIUM, AND PHOTOTHERAPY.

---

THE invaluable services rendered by X-rays in numerous affections, notably in epithelioma and other cutaneous lesions, are too well known to need elaboration. The action of the rays upon malignant disease of the deeper structures offers to the profession less promise of marked good than in the superficial variety. In tuberculosis, leukæmia, and in diseases and affections of a systemic nature, time alone will be the determining factor. As assertions without proofs must weaken any statement, the following portion of the work is devoted to the therapeutic action of this agent, its uses, its limitations, its disadvantages, from which the reader can glean more information and arrive at more decided conclusions, than by the recital of a number of theories, that at best would be inexact, hypothetical, and abstract.

---

#### CHAPTER I

##### ACTION OF THE X-RAYS ON BACTERIA.

THE results obtained by investigators on the question of the bactericidal power of the X-rays seem confusingly contradictory in many ways.

There are a number of authorities who, from clinical experience with the action of the X-rays on bacteria, firmly believe that the action of the rays upon certain of the micro-organisms is in the main detrimental to their development, and that destruction results from a few or more applications.

In March, 1896, Dr. W. W. Keen<sup>1</sup> reported the results obtained by the action of the rays on the pink-hued streptococcus, bacillus anthracosis, micrococcus prodigiosus, yellow sarcina, the tubercle bacillus, etc. He asserts that after exposures, first, for half an hour, and then twice for fifteen minutes, neither lethal nor inhibitory effects resulted upon the cultures. Dr. Davis, a few months prior to Dr. Keen's report, published exactly similar results, the latter's report confirming what had already been stated by Dr. Davis.

Berton<sup>2</sup> reports that he exposed cultures of the Klebs-Löffler bacilli, on bouillon, to the action of the X-rays for periods of sixteen, thirty-two,

<sup>1</sup>The American Journal of the Medical Sciences.

<sup>2</sup>Bull. Gén. de Thérap. November 8, 1896.

and sixty-four hours, but in no instance was he able to observe any result on the vital manifestations of the various micro-organisms.

Wittlin, Wolff, Grummaeh, and many others have made experiments on various types of bacteria, the results on the whole being negative.

Muhsam<sup>1</sup> reports that general tuberculosis in the guinea-pig is not affected by the X-rays, whilst to a certain extent a localized tuberculosis is hindered in its development.

Sormani<sup>2</sup> reports that he exposed numerous cultures of bacteria for six hours to the action of the X-rays, at a distance of from one to two inches. No alteration in the rapidity or mode of development, in the formation of gas, or in their color, fluorescence, or virulence was noted.

J. Brunton Blaikie<sup>3</sup> concludes that the rays have no visible influence on the growth of cultures of the tubercle bacillus, and that the chemical constitution of diphtheria toxin, like the delicate chemical structure of the retina, is not affected by their vibrations.

Gocht<sup>4</sup> reports the results of Minck's experiments. In his investigations Minck found that sunlight, daylight, and arc-light caused a weakened condition, amounting to injury to the bacteria in cultures. He exposed agar plates of typhoid bacilli to the rays for thirty minutes, without any injurious effects. By these experiments he proved that a fewer number of typhoid colonies developed on that part of the plate exposed to the influence of the rays than on that portion not so exposed. In Minck's later reports he specifies that no bad effects were produced on the typhoid bacteria when they were exposed to the action of the rays for eight consecutive hours.

H. Rieder<sup>5</sup> reports the experiments performed by Selhultze and Beck upon bacteria with color-producing abilities. The micro-organisms were planted in agar-agar soil on Petri dishes and exposed from thirty minutes to two and a half hours to the influences of the Röntgen rays. It was shown that after twenty-four hours' exposure, the bacteria had thrived quite considerably, also that those shielded by lead, from the full action of the rays, produced the same color as those that were subjected to the full action of the rays. In the experiments a coil of 12 cm. spark length was used, and the tube containing the bacteria was 25 cm. distant from the source of the rays. He concludes that the rays are negative as regards chromogenic or color-producing effect of micro-organisms, and that they cause a more rapid sporulation of the bacillus subtilis, while retarding that of the bacillus anthracis.

<sup>1</sup> Freie Vereinig. d. Chir., 1898.

<sup>2</sup> *Giorno della v. soc. it. dig.*, May and June, 1896.

<sup>3</sup> *The Scottish Medical and Surgical Journal*, May, 1897.

<sup>4</sup> *Fortschritte a. d. Geb. d. Röntgenstr.*, B. i., 1897-1898, page 34.

<sup>5</sup> *Münchener med. Wochenschrift*, 1898, No. 4, 101-104.

Drs. Norris Wolfenden and Forbes Ross<sup>1</sup> conducted experiments with the bacillus prodigiosus. They grew cultures on potato, carrying the same to the fifth generation. When exposed to the rays for a period of sixty minutes, there was a great increase of growth as well as of the pigment production. An 18-inch spark producing coil was used, 16 volts, with an amperage from 8 to 10. The culture was placed 6 or 8 inches distant from the vacuum tube. The same investigators observed only very slight changes in the protococcus.

Sabrazés and Riviére<sup>2</sup> report the result of their experiments conducted with the bacillus prodigiosus. The culture was placed 15 cm. distant from the vacuum tube, the dishes being covered with black paper, so as to exclude all possible light. They observed no changes in the chromogenic ability of the bacilli; the morphological characteristics, growth in particular, remained undisturbed by a daily hour exposure for 20 consecutive days. They also performed experiments with the rays on the heart of a frog and also upon the leucocytes, failing, however, to observe any important changes when the exposure lasted from 20 minutes to one hour or even longer.

Schaudinn<sup>3</sup> experimented on various types of unicellular organisms, showing that the protozoa differ greatly in their reaction to the rays. These differences depend possibly on the varying conditions of the nuclei, and on the presence or absence of capsules.

Dr. F. Robert Zeit, of the North-Western University,<sup>4</sup> gives the result of experiments upon various forms of micro-organisms, and arrives at the following conclusions:

"Bouillon and hydrocele-fluid cultures in test-tubes, or non-resistant forms of bacteria, could not be killed by the action of the rays after 48 hours' exposure, and at a distance of 20 mm. from the X-ray tube.

"Suspensions of bacteria in agar-agar plates exposed for a period of four hours to the rays, according to the plans carried out by Rieder, were not killed.

"Tuberculous sputum, even when exposed to the Röntgen rays for six hours, at a distance of from 16 to 22 mm. from the tube, caused acute miliary tuberculosis of all the guinea-pigs so inoculated. Röntgen rays have no direct bactericidal properties."

Lortet and Genod,<sup>5</sup> Fiorentini and Linaschi,<sup>6</sup> report an arrest of development of the bacilli in the guinea-pig.

<sup>1</sup> Lancet, 1898, p. 1752.

<sup>2</sup> Comptes-rend. Acad. d. Sc. Paris, 1897, cxiv. p. 979-982.

<sup>3</sup> Pflüger's Archiv f. d. ges. Physiologie, 1899; Archives d'Électricité Méd., No. 80, 1900.

<sup>4</sup> Journal of the American Medical Association, 1901, xxxvii. p. 1432.

<sup>5</sup> Comptes-rendus, 1896.

<sup>6</sup> British Medical Journal, 1897.



Rieder<sup>1</sup> has reported quite elaborately on this subject. He used Volt-Ohm tubes, and a coil of 12 inches (30 cm.) spark length. The distance of the anticathode from the cultures was four inches, and the exposure was from one to three hours. The cultures were covered by a leaden plate having a central aperture, so that the exposed part might be readily compared with the unexposed area. An agar plate culture of cholera vibrio was then placed in an incubator kept at a temperature of 37° C. after it had been exposed to the action of the rays for forty-five minutes. In the incubator was also placed a control culture plate, which had not been exposed to the rays. On the exposed plate, the colonies were markedly fewer in number than on the unexposed plate. Similar experiments were made with gelatine cultures of the bacterium coli, staphylococcus pyogenes aureus, streptococcus, bacilli of anthrax, and other bacilli. The tubercle bacilli, in meat extract, glycerin, and solution of peptone, were similarly affected.

In consequence of the bactericidal action of the Röntgen rays on plate cultures, he made further experiments on animals. Mice, rabbits, and guinea-pigs were inoculated with the bacilli of anthrax, streptococcus, and staphylococcus, and directly after injection they were subjected to action of the rays. The results being negative, he believed that the rays have no effect on acute infectious processes.

In order to study its action in chronic affections, Rieder experimented on animals with tubercle bacilli. After subjecting them to the action of the rays, necrotic destruction of the skin was observed. This came on very gradually, remained for a considerable period unaltered, and showed little or no tendency to extend. The affected skin was covered with scabs, and slight swelling and encapsulation of the tuberculous foci were likewise observed. In the control cases, the skin showed the presence of ulcers as if made by a thermo-cantery, and these had a decided tendency to increase in area. Disease of the internal organs set in later, in those animals which had been exposed to the rays. That local tuberculosis was arrested by the rays, and in many cases the general infection retarded, was proved conclusively, but nevertheless all the animals succumbed.

Rieder's experiments proved that the bacteria, when grown on agar-agar, blood serum, or gelatine, were killed when exposed to the action of the rays for one hour or more. When bacteria developed in suitable media outside of the body, their ability to develop further can be stopped, or at least discontinued to a degree, or even killed, by exposing them to the action of the rays. He proceeds to say that it may be unnecessary to kill the various bacteria inhabiting the human body, but only to inhibit their growth and reproduction.

<sup>1</sup> Münch. med. Wochenschrift, 1898, No. 4, S. 101; and No. 25, S. 773; 1899, No. 10; and No. 29, S. 250.

In experiments on developed germ colonies he found that cholera micro-organisms were killed after they had been exposed to the rays for a period of two hours or longer. Gelatine cultures of the bacillus coli, which had previously been in an incubator for from 12 to 24 hours and then subjected to the rays, showed colonies in the exposed portion of the dish which proved to be quite as large as those which were protected during the exposure from the influence of the rays, though they were diminished in number.

In another experiment Rieder employed eight dishes of extract of beef, glycerin, and peptone solution, prepared with a thin layer of new tubercle bouillon culture, exposing four dishes to the rays for a period of a little over an hour. These dishes together with those non-exposed were placed in an incubator at a temperature of 37° C. One week following he observed a luxuriant growth of the tubercle bacilli in the unexposed dishes, and in three of the exposed dishes he observed a diminished growth, while in the fourth dish there was hardly any growth at all discernible.

Rudis-Jicinsky<sup>1</sup> states that his results are similar to those of Rieder, hence he also favors the theory that the X-rays have a destructive action upon various bacteria. In the following table are to be seen the results he has obtained.

UNDER X-RAY IRRADIATION.	ACID.	MEDIA.	ALKALINE.
Bacillus anthracis.....	Negative,		Negative.
Bacillus tuberculosis (in sputum)....	Destroyed in 48 minutes,		Negative.
Bacillus tuberculosis (in flask).....	Destroyed in 50 minutes,		Growth accentuated.
Spirillum cholerae (in flask).....	Destroyed in 51 minutes,		55 minutes.
Bacillus diphtheriae (in flask).....	Destroyed in 46 minutes,		48 minutes.
Bacillus typho-abdominalis .....	Destroyed in 45 minutes,		49 minutes.
Streptococcus .....	Negative,		Negative.
Staphylococcus.....	Negative,		Negative.
Micrococcus pyogenes albus.....	Negative,		40 minutes.
Micrococcus gonorrhoeae .....	Destroyed in 35 minutes,		40 minutes.

The destruction of bacteria in cultures studied by careful observers, if not due to the direct action of the rays, is, he believes, brought about by electrical wave discharges. The effect of the X-rays on micro-organisms in tissues endowed with life, is at present an unsettled question. It is admitted that the effects here are different from those upon bacteria in cultures. That there is a decided effect upon streptococci, staphylococci, and certain other pus-producing organisms when in living diseased tissues cannot be doubted.

In the treatment of abscess, frequent irradiations cause the discharge to become sero-fibrinous in character, and greatly relieved of bacteria,

<sup>1</sup> New York Medical Journal, lxxiii., 1901, pp. 364-385.

with a consequent decrease in the virulence. This proves that the X-rays must have an effect upon the bacteria when imbedded in living tissues. Practically similar results may be observed in a superficial ulcer, which upon close microscopical examination shows the gradual disappearance of the pus micro-organisms. Ullman, Sambuc, Mongour, and many others seem to be of one opinion, that the rays cause a phagocytosis; but it is now generally believed that the rays produce an electro-chemic substance (an antiseptic) in each and every cell, which destroys the germs and aids in the healing process.



## CHAPTER II

### THE HISTOLOGICAL CHANGES INDUCED BY THE ACTION OF THE RÖNTGEN RAYS.

AMONG those who have studied most carefully tissue changes the result of the action of the rays are Gilchrist, Oudin, Barthélemy and Darier, Unna, Gassmann, Salamon, Scholtz, and many others. Dr. Kibbe, of Seattle, perhaps the first investigator to report authentically upon this subject,<sup>1</sup> relates the histological changes occurring in a piece of inflamed and discolored skin, removed without the aid of local anæsthesia; the outer layers of the skin, *i. e.*, the rete mucosum, presented the most striking alterations, particularly in the nuclei; the latter were observed to take hæmatoxylin and lithium carmin very feebly, and showed in addition a peculiar granularity, first indicated by the formation of a fine nucleolus, which was seen here and there in the process of division.

Near the stratum granulosum, the bodies of the cells were apparently becoming converted into keratin hyalin, as a first step to the increase in bulk of the stratum granulosum, by a development in their interior of coarse granules, staining deeply with hæmatoxylin and also with carmin. The corium exhibited the ordinary changes found in mild dermatitis, — *i. e.*, capillary dilatation, with collections of round cells scattered throughout its structure, particularly around the hair follicles. No blood extravasations in any of the specimens had been noted under the microscope or macroscopically.

Gilchrist<sup>2</sup> gives the results of his examination from dry, red, exfoliating dermatitic areas. His report is as follows: "Two portions of skin were removed for microscopical study, on the first day. One portion was removed from the dorsum of the phalangeal region of the third finger, and the other from the lateral margin of the head, over the base of the metacarpal of the little finger. Neither stained nor unstained sections demonstrated the presence of any foreign particles, and only showed chronic inflammatory changes. A decidedly large number of brown granules of melanin were found in the desquamating or exfoliating portion. The mucous layer did not appear to be thickened, though it was more pigmented than normal. In the stratum corium, the blood-vessels appeared irregular and dilated, and the pigment cells covering the papillæ were almost as numerous as are usually found in the stratum.

"It was suggested that particles of platinum might have passed from the tube through the glass bulb and have been deeply imbedded

<sup>1</sup>The New York Medical Journal, 1897, lxx. p. 71.

<sup>2</sup>Johns Hopkins Hosp. Bul., 1897, viii. p. 17.

in the tissue, giving rise to pigmentation. Portions of the exfoliating skin were accordingly submitted to Professor Abel for a chemical analysis, who stated that no particles of platinum could be detected."

Gassmann and Schenkel<sup>1</sup> made histological examinations of dermatitic areas, and found that the tissue was not necrotic but consisted of easily stained elements; degenerate forms were observed like those found in pathological tissue, which readily took up the nuclear stains. These presented peculiar aspects, some being drawn out into long threads, others were branched, indented, and grouped into irregular clusters, while there were also a few large lymph-vessels and capillaries distended with blood. Elastic fibres were plentifully distributed, together with collections of crowded mononuclear leucocytes, and a general but minute extravasation of erythrocytes. It is still undecided whether this peculiar tissue may be regarded as an altered subcutaneous tissue or as a newly formed tissue already undergoing degeneration. The healing process, which was very slow, began at the peripheral margin of the diseased area.

Oudin, Barthélemy, and Darier,<sup>2</sup> in a study of alopecia in guinea-pigs, found the prickle cell of the stratum granulosum ten to fifteen times thicker than is normally the case, the individual cells being only slightly altered. Not a single hair root was visible, and there appeared only slight traces of the previous hair follicles. All the hair papillæ, regeneration buds, and sebaceous glands were lacking.

The changes in the dermis were trivial, the white fibrous and yellow elastic connective tissue network being normal in texture. The large and smaller blood-vessels of both the cutis and subcutis were normal; nor were any changes in the structure of the nerve-fibres apparent. These writers conclude that, as a result of intense irritation, the least differentiated skin elements are apparently increased. On the contrary, the modified elements, hair, nails, and glands, undergo retrogressive changes and atrophy. They do not know whether these changes are due to nervous influence or to obliteration of vessels or other circulatory disturbances.

Unna<sup>3</sup> reports his investigations on a brown pigmented skin, obtained from a woman who had been, previous to her disease, exposed to the influence of the rays. He states that no increase of pigment was observed in the epidermis, but that there was a decided increase of coloring matter in the hair and in the connective tissue of the papillary layer; this appeared to be especially pronounced in the immediate vicinity surrounding the capillaries and the more superficial layers of the cutis.

<sup>1</sup> Fortschritte. Ein Beitrag zur Behandlung der Hautkrankheiten mittels Röntgenstrahlen, vol. ii. p. 128.

<sup>2</sup> Monatsch. f. prakt. Derm., 1897, xxv. p. 417.

<sup>3</sup> Deutsch. med. Ztg., 1898, xviii. p. 197.

Scholtz<sup>1</sup> says: "In almost every field were cells with nuclei divided into two or three parts without any attempt at karyomitosiis. The evidences of a beginning degeneration were apparently everywhere. The outlines of the cells were hardly distinguishable, and their protoplasm appeared blended into a homogeneous mass. The nuclei were merely shadows. In the hair follicles and sheaths, the changes in the cells appeared entirely analogous; and the loosening and falling of the hairs can be easily understood when taking into consideration this active cell degeneration.

"The corium was œdematous; the connective tissue fibres did not stain well, and appeared somewhat swollen and homogeneous. The basophilic reaction, of which Unna speaks, could not be demonstrated, though the elastic reticulum was still intact. No appreciable changes were apparent in the small vessels. Evidences of inflammatory reaction were only slightly intimated. The connective tissue cells and the sweat glands showed changes only to a slight degree. The cells of the intima were swollen, projected into the lumen of the vessels, and in some places showed evident proliferation, with a tendency to fall off into the blood current."

Gassmann<sup>2</sup> described the changes occurring in the larger and smaller blood-vessels of a part subjected to the action of the X-rays, as follows:

"Important changes are noticeable in the vessels. The walls of the small vessels and capillaries in the upper zone of an ulcer are changed into an irregular swollen mass, the lumen being sometimes entirely obliterated, and sometimes filled with corpuscles, in which latter case the vessel is surrounded by a collection of infiltrating cells. The intima is thickened and the endothelial cells are swollen, and often detached from the wall.

"The small vessels of the deeper tissues show similar changes of the intima, the lumen being entirely or partly obliterated. In the larger arteries and veins of the subcutis the intima is thickened, there is proliferation of the endothelial cells, filling perhaps half of the lumen. The intima shows numerous vacuoles and crevices. The muscular layer also shows vacuoles; the cells seem to be pressed together, are smaller, and the fibres between them do not stain well.

"Leucocytes are present in the media, and more numerously in the adventitia. Neither the inner nor the outer elastic layers are compact, but both are loose, the fibres separated from each other by spaces and increased in number. Not all, but many, of the large vessels show these changes. The lumina are sometimes empty, though not obliterated, sometimes filled with blood."

<sup>1</sup>Arch. f. Derm. u. Syph. 1902, lix. p. 241.

<sup>2</sup>Fortschr. a. d. Geb. Röntgenstrahlen, 1899, 11, p. 199.



## I. The Action of the X-rays on the Skin, or Röntgen Dermatitis.

That the X-rays have an effect upon normal as well as on pathological tissues is to-day an established fact. They cause changes not only in the superficial but also in the deeper structures. In the former we refer to changes in the several parts of the skin and the subcutaneous tissue; in the latter we allude to possible changes produced in organs such as the lungs, heart, kidneys, and other viscera.

Shortly after the discovery and application of the rays for diagnostic purposes, it was noted that in some of the cases, a dermatitis of varying severity, with epilation of the hair occurred. This untoward incident was the genesis of X-ray therapy.

### A. CAUSES OF X-RAY DERMATITIS.

Many theories have been advanced regarding the etiology of X-ray dermatitis. Prominent among these are the following :

1. Flight of minute platinum atoms.
2. Ultra-violet rays.
3. Cathode rays.
4. Röntgen rays.
5. Electrical induction.
6. Ozone generation in the skin.
7. Idiosyncrasy.
8. Faulty technic.

1. This theory lacks confirmation and is not generally accepted.

2. Stine<sup>1</sup> and Goldstein<sup>2</sup> state that burns received on exposure of the body to the excited Crookes tube are not due to the X-rays, but to the ultra-violet light coming from the tube.

3. Freund maintains that the phosphorescent glow set up by the impact of the cathode rays gives off a certain number of ultra-violet rays. This view is endorsed by Gilchrist,<sup>3</sup> and Foveau de Courmelles.<sup>4</sup> Sir Oliver Lodge<sup>5</sup> asserts that cathode rays do penetrate the tube and accompany the X-rays.

4. By many it is believed that the X-ray radiations are directly responsible for the dermatitis produced. Among the authorities that favor this view may be mentioned Gassmann, Schenkel, Rieder, Forster, and Kienböck.

5. Rollins<sup>6</sup> exposed his hand to a tube whose resistance was so high

<sup>1</sup> *Electrical Review*, November 18, 1896.

<sup>2</sup> *Sitzungsbericht d. k. preuss. Akad. d. Wissenschaften*, Band viii., quoted by Holz knecht.

<sup>3</sup> *Bulletin, Johns Hopkins Hospital*, February, 1897.

<sup>4</sup> *Congr. f. Neurolog.*, Brussels, 1897.

<sup>5</sup> *Archives of the Röntgen Ray*, April, 1904.

<sup>6</sup> *Electrical Review*, Jan. 5, 1898.

that no current could be forced through it with the generator used; nevertheless, the hand was burned, in spite of the fact that no X-rays were produced. He therefore believed that X-ray burns could be produced by electricity, but did not show that they could not also be produced by the X-rays.

Those favoring the above theory are Schall, Leonard, Bordier, Salvador, Gocht, and Apostoli.

6. Tesla<sup>1</sup> believes that burns are due to the ozone generated on the skin and to a small extent to nitrous acid. He therefore interposed a screen made of aluminium wire, connected with the ground, between the tube and the person, and no burn was produced. Before he took this precaution one of his assistants was burned.

Dr. F. J. Clendinnen has made some experiments on the action of X-rays on the air. He found that air which had been irradiated for ten minutes gave a slightly acid reaction with phenol-phthalein. Further tests with diphenyl-sulphonic acid showed this to be due to the production of nitric acid. He holds that the healing and stimulating effects of the X-rays are partly due to this production of nitric and nitrous acids. This would account for the bronzing and pigmentation due to X-rays, since, when nitric acid comes in contact with any proteid matter it turns yellow owing to the formation of xanthoproteic acid, which acid would further be darkened by the action of the ammonia in the skin.<sup>2</sup>

The above theories are not accepted by Oudin, Barthélemy, and Darier.

7. Some individuals show a marked susceptibility to the action of the rays. All operators confirm this view. In some patients, X-ray burns have been recorded where a single exposure of one minute duration was given.

8. The principal factors in faulty technic are :

- (a) Too close proximity of the tube to the part to be irradiated.
- (b) The degree of vacuum of the tube, the soft tube being most prone to produce X-ray dermatitis.
- (c) Prolonged or repeated exposures.

The opinions held by various observers as to the etiology of X-ray burn, as detailed above, may not be endorsed to-day by some of these very scientists. As the study is being more and more unfolded, new theories are from time to time being advanced to account for X-ray dermatitis.

## B. CLASSIFICATION OF X-RAY DERMATITIS.

It is customary to divide X-ray dermatitis into the *acute* and *chronic* forms.

<sup>1</sup> Electrical Review, December 2, 1896.

<sup>2</sup> Intercolonial Medical Journal, October, 1904.

The *acute form* may appear 24 hours after the irradiation, or may not manifest itself for two or three months subsequently; it is characterized by the presence of an erythema. This erythema is attended with intense itching, which in a few days may give rise to vesicle formation. The erythema may be preceded by pigment formation.

As soon as the cutaneous pigmentation has taken place, an effect upon the hair may be observed. The hair loses its natural lustre, the individual hairs become brittle and break off close to the hair follicle upon the slightest friction or combing.

It should be remembered, when there is an erythema, that this in itself is sufficient to cause a loosening and falling of the hair, without injury to the follicle, hair papilla, etc. Hair rich in pigment falls out more readily than hair of a sparser pigment. I have seen two cases where the hair had been removed from the entire scalp by the X-rays, to grow again, and more luxuriantly, in a short time.

In mild cases this is simply a transient erythema, lasting perhaps a few days, followed by an exfoliation of the superficial epidermis. There may be a hyperæsthesia of the skin and a mild burning sensation, though no real pain is experienced. In the hairy portions, epilation may occur without any active inflammatory signs.

In cases of the second degree there is a formation of serous or purulent blebs following the erythema, and bearing a close resemblance to a scald, but differing from the latter, in that it is decidedly slower in healing and less acute in character.

In the worst cases, the process, instead of disappearing in a few weeks, extends to the deeper layers of the skin and to the subcutaneous tissue, resulting in the formation of a leathery slough, surrounded by a brawny indurated swelling with ill-defined limits. The process is exceedingly slow and obstinate, and possesses a tendency to progress. It is generally very painful, usually resisting all treatment in a most remarkable way.

The *chronic form*, found most largely in the persons of operators (Fig. 209), may be regarded as a long-continued form of the acute variety, and produced by the constant irritation of the action of the rays. Following the acute form, the nails become brittle and thinner, and show the presence of linear striations, and later of furrows.

Still later onychia develops, and the nail is frequently shed. The knuckles become sensitive from a chapping of the skin, serum exudes, and an itching sensation develops, which is often followed by numbness and anæsthesia. The skin becomes hard and leathery, warty excrescences form, and from the base of these excrescences a clear serum issues. Frequently these growths become detached and offer a raw, sensitive surface. While the operator's hands are most frequently "burnt," the phenomenon may manifest itself on any part of the body, especially the face and the chest.





FIG. 209.—AUTHOR'S HANDS.—Showing the result of chronic X-ray dermatitis  
(Began in 1899 and the above photograph taken in 1903.)



Kienböck<sup>1</sup> classifies X-ray burns as follows :

Those of the *first degree*, which appear from twelve to sixteen or more days after exposure. The hair loosens, falls out, and leaves the skin smooth, bald, and occasionally pigmented.

Those of the *second degree*, where the exposure has been more intense and appears after a briefer interval than in burns of the first degree. There is localized or general swelling. The hyperemia, at first light, later assumes a darker color. There is marked irritation. These symptoms are followed by loss of hair, and by marked cutaneous pigmentation with subsequent scaling; the skin is smooth and sensitive, of a delicate hue, and devoid of hair; after a time, however, the part again assumes its normal aspect, a slight pigmentation perhaps remaining.

Those of the *third degree*. Blisters and extensive exfoliations are present, the hair fails to grow again, changes in the pigmented spots are permanent, and there is atrophy of the cutis and papillæ, with the formation of painful cicatrices.

Those of the *fourth degree*. This is characterized by a superficial dry necrosis. After a latent period of a fortnight, the skin is darkly discolored, and is the seat of ulceration, which may be of an indefinite duration. The condition may be painless.

The above methodical classification is purely arbitrary. I have seen many cases of dermatitis where the symptoms did not follow these typical stages.

### C. THE LATENT STAGE; FREQUENCY AND SUSCEPTIBILITY IN X-RAY DERMATITIS.

E. A. Codman<sup>2</sup> shows that the latent period in X-ray dermatitis varies from an interval of 24 hours up to the fourth week after the irradiation.

In 9 instances, signs or symptoms were noticed within	24 hours.
In 6 instances, signs or symptoms were noticed within	2 days.
In 6 instances, signs or symptoms were noticed within	3 days.
In 2 instances, signs or symptoms were noticed within	4 days.
In 5 instances, signs or symptoms were noticed within	5 days.
In 3 instances, signs or symptoms were noticed within	6 days.
In 3 instances, signs or symptoms were noticed within	7 days.
In 4 instances, signs or symptoms were noticed within	8 days.
In 2 instances, signs or symptoms were noticed within	9 days.
In 9 instances, signs or symptoms were noticed within	10 days.
In 8 instances, signs or symptoms were noticed within	10-14 days.
In 8 instances, signs or symptoms were noticed within	15-21 days.
In 2 instances, signs or symptoms were noticed within	22-28 days.
In 3 instances, signs or symptoms were noticed after the	4th week.

From this table we may observe that it is impossible to fix an exact time when the first symptoms may be expected, but the majority of cases of X-ray dermatitis make their first appearance from the 10th to the 13th day, the cases occurring later having really started previously, but the symptoms were insufficient to attract the patient's attention.

<sup>1</sup> "Hautveränderungen durch Röntgenbestrahlung bei Mensch und Thier," Wiener med. Presse, 1901, pp. 874-879.

<sup>2</sup> Philadelphia Medical Journal, March 8, 15, 1902.



In seven cases, two of which came under my care, a dermatitis had been set up from two to eight hours after exposure. There are two cases on record where dermatitis did not appear until the thirty-second day, but I believe it questionable whether the X-rays were instrumental in bringing about this belated condition.

In 1898 H. Gocht<sup>1</sup> stated that in the Hamburg-Eppendorf Hospital, out of a total of over 2000 exposures, there was only one burn.

Albers-Schönberg, in the same year, was also of the opinion that the probability of a burn is only very small. He, perhaps the most competent X-ray expert, says that, despite his frequent irradiations for diagnostic purposes, up to that time (1898), he had never seen a burn; and that was at a period when exposures of twenty minutes were customary, with the tube very close to the body.

Hoffa<sup>2</sup> says that the occurrence of the burn is in the proportion of 7 to 10,000, which small figure (0.7 per cent.) is not obtained in the statistics of even the most harmless operation.

It has been said, that the individual "disposition" is an important factor in the relative frequency of X-ray burns, and that this disposition varies according to the types of the pigments of the body. Different parts of the body react variously to the rays, the hairy regions being especially sensitive.

In an examination of 8000 patients for diagnostic purposes, I have met with but three mishaps,—one case each of epilation, vesication, and ulceration.

Sjörögen and Sederholm<sup>3</sup> are strongly impressed with the fact that blondes and brunettes react differently to the action of the rays, as shown in the following :

#### A—BLONDES.

- Case 13, with 21 exposures ; reaction mild.
- Case 4, with 19 exposures ; reaction mild.
- Case 6, with 12 exposures ; reaction very mild.

#### B—BRUNETTES.

- Case 1, with 22 exposures ; reaction strong.
- Case 2, with 20 exposures ; reaction very strong.
- Case 5, with 18 exposures ; reaction present.
- Case 7, with 16 exposures ; reaction strong.
- Case 7, with 15 exposures ; reaction ; second period, strong.
- Case 8, with 15 exposures ; reaction medium.
- Case 9, with 18 exposures ; reaction intense.
- Case 10, with 29 exposures ; pronounced swelling.
- Case 11, with 35 exposures ; very strong reaction.

<sup>1</sup> American Electro-Therapeutic and X-Ray Era, May, 1903.

<sup>2</sup> Quoted by Schürmayer, Fortschritte a. d. Geb. d. Röntgenstr., 1901, 1902, v. pp. 48-51.

<sup>3</sup> Ibid.

Codman<sup>1</sup> says: "Many assertions have been made that the static machine is less liable to the production of injuries by the X-rays than any other form of apparatus, because of the low amperage required; this statement, however, is not borne out by the present analysis.

"In the cases in which the kind of apparatus is recorded, 11 were caused by static machines; of these 3 were severe; 11 were caused by Tesla coils; of these 5 were severe; 42 were caused by forms of induction coils; of these 18 were severe.

"On the other hand, coils have been far more commonly used than static machines or the Tesla apparatus, probably in the proportion of 3 to 1. In the other cases in which the apparatus is not spoken of, it is probable that a static machine would have been used and not mentioned. I believe that X-ray dermatitis occurs with equal frequency both with the coil and with the static machine."

Codman further says: "Unfortunately, the quality of the tube is not recorded often enough to give us effective data. Where it is recorded it is usually stated to be 'soft.' It is the general impression of skiagraphers that soft tubes have more therapeutic influence than hard. It is probable that the distance from the skin and the time of exposure are more important factors.

"Maximum recorded distance from tube to skin at which injury has occurred, was 50 cm. (statement of patient). Minimum recorded distance from tube to skin, 1 cm. Maximum recorded time of exposure, 20 hours (ten exposures). Minimum reported time of exposure, 5 min. (other data not given). Considerable inaccuracy probably exists in the accompanying reports of times and distances. One writer speaks of 'distance from tube to skin;' another from 'tube to plate,' or from 'platinum terminal to skin,' still others say the 'tube was so many inches distant,' or perhaps neglect the entire data."

Leopold Freund,<sup>2</sup> whose experience in this field has been enormous, says: "The dangers of Röntgen therapy are not confined to primary Röntgen dermatitis, which may take months or even years to heal, but include permanent changes in the integument, atrophy, scleroderma, and telangiectases, which may follow prolonged and repeated irradiations. The most to be dreaded is the primary Röntgen dermatitis. Its protracted duration, its painful nature, and the comparative uselessness of treatment, render these cases the bane of both doctors and patients.

"The question arises, What is the percentage of accidental burns in all cases treated by Röntgen therapy? According to Codman, up to the year 1902, the total number of recorded cases of severe burns due to the Röntgen rays is 172. He calculates that such accidents do not exceed one

<sup>1</sup> The Philadelphia Medical Journal, March 8 and 15, 1902, ix. pp. 4-38.

<sup>2</sup> An address delivered before the Wissenschaftliche Versammlung des Wiener Medizinischen Doktorenkollegiums, February 12, 1906.

in 5000. In the hospitals of Boston there were only four cases of burns in 20,000 radiographic exposures.

“Hahn has collected statistics from a number of sources :

Hahn	treated 303 cases, and had 2 Röntgen ulcers.
Schiff	treated 505 cases, and had 3 Röntgen ulcers.
Müller	treated 47 cases, and had 1 Röntgen ulcer.
de Nobele	treated 42 cases, and had 1 Röntgen ulcer.

“Holzknecht gives the number of cases in which reaction occurred, and not the total number irradiated. In 4872 cases of reaction, he got 44 cases of ulceration.

“Many other authors record cases of ulceration, but do not give the total number of cases treated. All agree that unforeseen secondary effects may include scarring, pigmentation, telangiectases, atrophy of the skin and nails, keloid, and sclerodermic changes.”

Between the years 1896 and 1904, Freund treated 369 cases, with a total of 11,808 irradiations. In these 369 cases he had 3 intense reactions.

#### D. PATHOLOGICAL PHYSIOLOGY.

Huntington<sup>1</sup> quotes Rudis-Jicinsky in that an X-ray dermatitis consists of an acute, subacute, or chronic necrobiosis. Rudis-Jicinsky, in a later article, states that “the irritation of the peripheral extremities of the sensory nerves causes a paralysis of the vaso-motors of the vascular area affected, that spasmodic contraction of the arterioles and capillaries follow, and the proper nutrition of the cells is impaired. With these changes, which are directly dependent upon disturbance of the circulation, there are changes in the parenchyma cells of the affected region. The death of tissue follows, caused by permanent stasis in the blood-vessels.”

Lowe<sup>2</sup> mentions the fact (first demonstrated by Lord Kelvin), that a bar of iron, electrified and insulated, can be discharged or de-electrified by means of the X-rays. He seems to be of the opinion that an X-ray dermatitis depends very largely upon a similar action on the trophic nerves of the parts subjected to exposure.

E. A. Codman<sup>3</sup> supports the theory that attributes the lesions to a primary action on the trophic nerves of the blood-vessels and the skin. He says, “the delay in the appearance of the lesions after the exposure, their progressive character, and their failure to react to stimulating treatment, are the strongest reasons for this view.” His reports of the

<sup>1</sup> Annals of Surgery, December, 1901.

<sup>2</sup> British Medical Journal, January 18, 1902.

<sup>3</sup> Philadelphia Medical Journal, March 8-15, 1902.



microscopic examinations of the excised tissue agree in that the smaller arterial branches are occluded, and the appearances are not unlike those of necrosis and inflammation due to other causes.

Apostoli<sup>1</sup> ascribes the cause of these burns to an electrical stream of high tension issuing from the Crookes tube.

Oudin, Barthélemy, and Darier<sup>2</sup> believe that the changes in the skin are not caused by the local direct action of the rays on the cells of the cutis and epidermis, but that the influence is transmitted indirectly through a tropho-neurotic action, having its seat entirely in the central nervous system.

Destot<sup>3</sup> also regards these changes as having a tropho-neurotic origin. Kaposi explains them by a paresis of the blood-vessels, whilst Bordier is of the opinion that they originate in a disturbance of nutrition.

Kienböck believes in a chemical action leading to disturbances of metabolism, by which the cells of the tissue are led to react in the form of a Röntgen dermatitis.

Freund maintains that, through the destruction of tissue elements, certain products arise whose absorption leads to constitutional symptoms. This would explain the appearance of fever at the commencement of severe Röntgen dermatitis, before any excoriation or ulcer affords the opportunity for local infection.

L. Jankau<sup>4</sup> believes that an electrolytic analysis of the cells takes place from irradiation, whereby the tissues are chemically affected, and inflammation is provoked.

Gassmann and Schenkel<sup>5</sup> have examined histologically this form of dermatitis. They found that the tissue was not necrotic in the ordinary acceptation of the term, but consisted of various characteristic elements easily stained. The chief of these were bundles of collagen fibres of normal appearances, their nuclei being readily stained by the usual methods. Here and there were seen degenerate forms, like those found in pathologically altered tissue, which readily received nuclear stains. These were of peculiar aspect, some being drawn out into long threads, others much branched, indented, or grouped in irregular clusters. There were also a few large lymph-vessels, and capillaries distended with blood. Elastic fibres were found in abundance, with here and there collections of crowded mononuclear leucocytes or a slight extravasation of blood. The adipose tissue was unaltered.

Unna<sup>6</sup> alone has had an opportunity of examining microscopically a dermatitis erythematosa set up by X-rays in the human skin. He found

<sup>1</sup> New York Medical Journal, October, 1897.

<sup>2</sup> Monatschrift f. prakt. Dermatologie, 1897, xxv. p. 417.

<sup>3</sup> Compt.-rend. Acad. d. Sc., Paris, 1897, cxxiv. pp. 1114-1116.

<sup>4</sup> Internat. photog. Monatschr. f. Medicin, 1898, vol. v. pp. 1-7.

<sup>5</sup> Fortschritte, vol. xi. p. 128.

<sup>6</sup> Fortschritte a. d. Geb. d. Röntgenstrahl., B. xi., H. 3, pp. 118-119.

the elastin altered, and the bands of collagen swollen, whence he concludes that the Röntgen rays attack even the more resisting tissues of the skin. He thereby explains their cumulative action.

Sequeira<sup>1</sup> speaks of a few cases where the scar tissue that remained contained many vascular places, designating them as telangiectases. I have seen three such cases, though I could not study the condition in detail as I would have liked.

In a previous paragraph it is mentioned that the changes resulting from the action of the X-rays are usually atrophic in form. On the other hand, there is a hypertrophic tendency about the joints of the phalanges and especially on the dorsum of the hand. The condition spoken of as hyperkeratosis is characterized by an over-development of the horny layer of the epidermis. These keratotic areas are nothing more than elevations that have a broadened base, and which frequently project above the outer surface of the skin in the form of small "peaks."

Usually the bases of the keratotic peaks are not inflamed, though I have seen three cases where the opposite condition was true. Cases are reported where there have been three keratoses distributed over the entire anterior surface of the thorax, the dorsal surface of hands and feet, and over the thighs. Between the keratotic peaks, the skin was usually atrophied and pigmented.

Johnston<sup>2</sup> speaks of the keratotic peaks as "precancerous patches," he believing that these points are very prone to undergo epitheliomatous changes. He reports a case where a surgeon developed numerous keratoses on the back of both hands, the result of extensive use of the rays. Two of the larger peaks were excised and studied microscopically; the first revealed the cutis in a state of subacute inflammation, accompanied by an intense lymphocytosis with a proliferation of fibroblasts.

#### E. DURATION.

The duration of chronic dermatitis is often prolonged over months and years, running an uninterrupted course. Cicatrices often remain after the lesion has healed. In the cases of X-ray operators, chronic dermatitis leaves the nails disfigured and deformed, and they never again regain their normal appearance and condition. The skin of the hand remains tough and indurated, with the subsequent occurrence of atrophy.

The bones suffer no change, though the knuckles are enlarged, and there is hypertrophy of the periarticular tissues (as is evidenced in my own hands).

Movements of the fingers, in flexion and extension, are painful and limited. Itching, paræsthesia, and anæsthesia are present to a greater or

<sup>1</sup> The British Dermatological Journal, 1902, xiv.

<sup>2</sup> The Philadelphia Medical Journal, February 1, 1902, pp. 220-221.

lesser degree; this renders the operator nervous, irritable, and generally ill. Months and years of rest and change of occupation may fail to show any improvement in the condition, the skin remaining thickened, dry, and shining; there being present numerous red patches, with the joints flexed and sensitive.

When the X-rays were first brought to the notice of the medical profession, the number of experimenters in this fascinating field were numerous. To-day, many of these enthusiastic votaries have become its victims, and it is a painful duty to inscribe the names of the following as among the more prominent workers who have perished,—martyrs to a noble cause: Mr. Clarence Dally, Thos. A. Edison's assistant, of New Jersey; Mrs. E. Fleischman Aschheim, of San Francisco; Dr. Louis A. Weigel, of Rochester, New York; W. C. Fuchs, of Chicago; Dr. A. Barry Blacker, of London; M. A. Radiquet, of Paris. The number of operators that have been disfigured, maimed, and injured would form a deplorable list of tremendous proportions.

#### F. PREVENTIVE MEASURES AGAINST X-RAY DERMATITIS.

As a prophylactic measure, the patient's susceptibility should be carefully ascertained by interrupted small doses of the rays. The character of the tube must be considered. Soft tubes produce a dermatitis more readily than do hard tubes, because the latter afford less absorption. Another matter for thought, is the distance of the tube from the patient. The more distant the tube, the less will be the danger of burning the patient. In treating the deeper-seated structures, the surrounding healthy parts should always be screened from the rays by thin sheets of lead. For filtering off the soft and unnecessary rays, advantage is taken of the use of a piece of leather or aluminium (grounded) applied over the part to be irradiated. As a prophylactic measure the treatment first employed by Dr. C. L. Leonard, of Philadelphia, may be mentioned. He employs the compound stearate of zinc powder, with ten per cent. ichthyol, in cases under treatment, believing that it not only relieves the symptoms of acute dermatitis, but also allows a stronger dosage to be employed.

#### THE PROTECTION OF THE OPERATOR.

For his own protection, the operator should never use his hand to test the intensity of the rays. While the patient is undergoing treatment or examination, the operator should be in a communicating room or behind a lead screen or in a sentry box, where he can observe the fluorescence of the tube from a mirror suspended at a convenient angle from the ceiling. The best place for the operator to have his lead protection, is behind the anode. The absence of the operator from the room is always advisable because its atmosphere becomes ionized by the rays.



To discover the presence or absence of the rays, the operator may employ an electroscopie or photographic plate, and wherever they are detected that region is unsafe for the operator. (Fig. 210.)

The Crookes tube should be covered with an opaque rubber shield, or, as some recommend, with lead glass containing an interval of ordinary glass, for the passage of the rays. Müller paints the active hemisphere

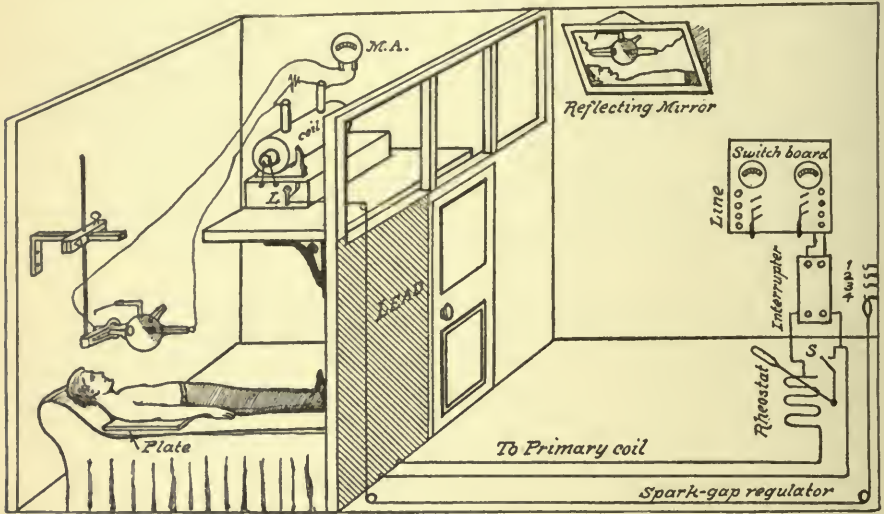

FIG. 210.—Author's scheme for the operator's protection.

with a black opaque material and employs diaphragms of various sizes. The operator should still further protect himself by wearing special opaque rubber gloves and an apron, the latter to prevent injury to the testicles. Spectacles of lead glass are worn by some to protect the eyes. It is far better, however, for the operator to be out of the room and dispense with such protecting devices.

#### G. TREATMENT OF X-RAY DERMATITIS.

Treatment of the *acute form* may be similar to that employed in any other acute inflammation of the skin.

Slight erythema may disappear within a few days, but when the irritation is excessive and accompanied by intense itching, soothing remedies, as, zinc oxide ointment, compresses of ice, boric acid, etc., may be employed. When the vesicles burst and the skin resembles the lesion of pustular eczema, a warm normal salt solution proved soothing and efficient in one of my patients. Carbolic acid, bichloride of mercury, and other antiseptics produce irritation. I used orthoform on my own hand, with the result that a general inflammation resulted.

Too much medication is dangerous. Dry dressings are to be preferred. My treatment of acute X-ray dermatitis consists in cleansing the part with sterile water, covering it with sterile gauze, and in enjoining absolute rest of the part. The general health should be inquired into, and the patient's diet should be simple and non-stimulating.

For the intense itching, immersion in hot water and the employment of dilute solutions of cocaine are to be recommended. If the operator uses a dilute solution of carbolic acid for this purpose, he should remember that its too frequent application may increase the irritation and even produce gangrene. Normal salt solutions and sterile gauze dressings brought about rapid relief in an acute case under my care in the Philadelphia Hospital.

Treatment of the *chronic form* is the same as for the acute form, plus other measures. The latter include the employment of picric acid, various ointments containing boric acid, zinc oxide, calcium salts, aristol, orthoform, etc., with lanolin, cold cream, vaseline, etc., as a base. Some recommend powders of the above in place of ointments. Some urge the use of a poultice as an analgesic. When the warty excrescences appear, it is good practice to file them down with a small strip of sandpaper. When the knuckles are thus involved, I advise the use of a digital (palmar) splint, which, however, must not be worn too long, lest ankylosis set in. I also advise touching the fissures in the skin with a ten per cent. solution of argyrol. As salicylic acid is very stimulating, its use is contraindicated. Continuous moist dressings should not be used, as maceration of the skin is sure to ensue. When the skin appears dry and parched, nothing is so valuable as the nightly application of lanolin.

It is worthy of remark that frequently a chronic X-ray dermatitis, apparently cured, breaks out anew and with increasing severity. In such cases I employ an application of twenty per cent. of zinc oxide in lanolin for several days. If continued too long over-stimulation will occur. The internal administration of arsenic and the iodides is most valuable. Alcohol in all forms is strongly contraindicated.

The following treatments are appended :

F. Engman<sup>1</sup> says that in acute cases of the second degree or milder, where infection and ulceration are not complications, he has controlled the intolerable itching, assisted repair, and kept the surface aseptic, by the employment of the following formula, which has yielded him excellent results.

R Boric acid.....	12 drams	(46½ grammes).
Zinc oxide, starch, bismuth subnitrate, of each,	1 ounce	(31 grammes).
Olive oil.....	1 ounce	(30 c.c.).
Lime water.....	3 ounces	(90 c.c.).
Rose water.....	12 drams	(43 c.c.).

<sup>1</sup> Interstate Medical Journal, July, 1903.

The powder should be well triturated in a mortar and the lanolin added. The olive oil and lime water are thoroughly mixed, and slowly added to the powder and lanolin, keeping constantly stirring; after which the rose water is added, and the whole beaten up in the mortar into a light creamy paste. If there is much pruritus, 1 or 2 per cent. of carbolic acid can be added to the mixture. This creamy paste should be spread on several thicknesses of absorbent gauze, and applied to the surface, and a sheet of gutta-percha tissue placed over it, to prevent evaporation. It is very soothing because of the great percentage of water it contains, and acts almost as a lotion without the disagreeable effects.

Mr. H. Lyle, Senior Surgeon to the Liverpool Hospital, believes X-ray burns to be reasonably amenable to treatment. The method recommended is the free application of an ointment, composed of one dram of lead oxide, two drams of carbonate of zinc, one dram of glycerin, half a dram of olive oil, to one ounce of benzoinated lard.

Unna<sup>1</sup> advises that the hands be bathed from one-quarter to three-quarters of an hour in warm water with superfatted soap, to be followed by the application of one of the following ointments :

R Ung. Hebræ rec. par.....	25.0 grammes	(386 grains).
Sol. calcii chlorati.....	10.0 grammes	(154 grains).
Glycerini.....	5.0 grammes	(77 grains).
Adipis lanæ.....	10.0 grammes	(154 grains).

or

R Ung. Hebræ rec. par.....	35.0 grammes	(540 grains).
Acidi salicylici.....	2.5 grammes	(39 grains).
Sap. kalini.....	2.5 grammes	(39 grains).
Vaselini.....	10.0 grammes	(154 grains).

Dr. Nogier<sup>2</sup> recommends for the burning, itching, and pain in acute dermatitis :

R Water.....	3 ounces	(90 grammes).
Gélose.....	20 grains	(1.25 grammes).
Glycerin, oxide of zinc, of each....	3 drams	(12 grammes).

Norman Walker<sup>3</sup> uses the following :

R Prepared chalk.....	3 drams	(12 grains).
Olive oil.....	2 drams	(8 grains).
Prepared lard.....	1 dram	(4 grains).

<sup>1</sup> Fortschritte auf dem Gebiete der Röntgenstrahlen, vol. viii., No. 2.

<sup>2</sup> Archives d'électricité médicale, Sept. 25, 1906.

<sup>3</sup> British Medical Journal, 1901, ii. p. 852.



Dr. J. Hall Edwards<sup>1</sup> advises the use of the following :

R Sulphate of zinc.....	5 grains	(0.32 grammes).
Tincture of lavender.....	60 minims	(4 c.c.).
Glycerin.....	60 minims	(4 c.c.).
Water.....	1 ounce	(30 c.c.).

Ft. lotio.

He likewise advises the application of olive oil several times daily to the hands, to be followed with hot water and superfatted soap.

Since the above was written, I have been using Eichhoff's superfatted resorcin soap, but the results are unsatisfactory, as the soap removes the epithelial layer and renders the irritated remaining layers most tender. Oudin recommends a peroxide of hydrogen dressing in cases of erythema and excoriations.

M. W. Brinkmann advocates Bier's method of inducing passive hyperæmia,—*i. e.*, by constriction of the venous circulation above the diseased area.

Professor Lassar, of Berlin, applied radium over the ulcerated spots of my hands, but I could derive no benefit from the treatment, as I could not continue it. But I am doubtful as to its ultimate efficacy.

In passing, it is interesting to note that in the treatment of X-ray burns advantage has been taken of the caloric power of the red rays and of the absence in these rays of chemical properties. The experiments of Finsen, Schenk, and Graber have abundantly proved that white light is a stimulating agent of considerable power, and Bar and Boullé<sup>2</sup> describe at length, the case of a pregnant woman treated at the Infirmary of Saint Lazare, who suffered from blenorragia, accompanied by abdominal pains. She had been pregnant about three months, when the rays were applied to the abdomen in the hope of producing a blister and thus allaying her intense pains. An ulcer formed which baffled all treatment. Two months after delivering two healthy infants the woman was placed in a sunny corridor, and each day the rays of the sun were sent through red glass and allowed to fall on the abdomen. Over the ulcerated area was placed a transparent sheet of celluloid. At night the ulcerations were covered with an inert powder. Gradually the crusts produced by the X-rays sloughed off, and, fifty days after this treatment was begun, the healing was hastened by cauterization with silver nitrate.

Freund and Huntington advise excision of the ulcer in obstinate cases and that the operation of skin grafting be resorted to. I concur in this advice. Apostoli and Oudin recommend the effluve from a static machine and a resonator respectively. I do not believe that, at the present day, there is any agent known for the cure of X-ray dermatitis. All of the proposed measures are merely palliative.

<sup>1</sup> The Archives of the Röntgen Ray, October, 1903.

<sup>2</sup> Bulletin de la Société d'Obstetrique de Paris, 1901, vol. iv. pp. 251-266.

## II. Remote and Indirect Action of the Rays.

Peculiar sensations attending and sometimes subsequent to irradiation are often complained of by the patient. These include nervous disturbances,—*i. e.* dizziness, somnolence, and tinnitus. The circulatory disturbances are increase in the pulse rate, palpitation, and cardialgia. Digestive disturbances manifest themselves in nausea, vomiting, and occasionally in diarrhoea. These symptoms may occur in both the patient and the operator. It is my own belief that some of these symptoms may be manifestations of psychical influences.

### GENITO-URINARY SYSTEM (STERILITY).

That the Röntgen rays are capable of inducing at least temporary sterility should never be lost sight of. Long ago the possibility of this unfortunate occurrence was emphasized by Albers-Schönberg.<sup>1</sup>

The experiments of Halberstaedter<sup>2</sup> disclosed the fact that marked macroscopic and microscopic changes occurred in the ovaries of rabbits exposed to the rays. "The histological change most in evidence was the complete disappearance of the Graafian follicles, in about fifteen days. Whether this loss is permanent and whether or not regeneration can take place, has not yet been determined. It was also found that the ovaries seemed more sensitive to the effects of the rays than the outer skin of the abdomen, and, when compared with control experiments in male rabbits, developed degenerative changes in shorter time and with fewer exposures. How far these observations in animals apply to human beings cannot be definitely stated, nor is it known how permanent the effect may be. Of course the question of individual susceptibility must also be taken into account, but since the wearing of an apron impervious to the rays, or the encasing of the focus tube so as to prevent the escape of all rays except those intended for a particular region under treatment, and to avoid applying the rays to 'danger zones,' would seem to obviate all danger in this direction."

Albers-Schönberg<sup>3</sup> called attention to the fact that in male rabbits and guinea-pigs, in which the abdomen was exposed to the action of the X-rays, azoöspemia was gradually developed. Frieben<sup>4</sup> found that this was due to the disappearance of the epithelium in the seminal tubules, which resulted in an atrophy of the testes.

Before the January (1905) meeting of the section for Genito-Urinary diseases of the New York Academy of Medicine, the statement was made by F. Tilden Brown and Alfred T. Osgood that men, by their presence in

<sup>1</sup> Münch. med. Wochen., 1903, i. 43.

<sup>2</sup> Berliner klin. Wochensch., January 16, 1905.

<sup>3</sup> American Journal of Surgery, April, 1905.

<sup>4</sup> Münch. med. Woch., 1903, No. lii. p. 2295.

an X-ray atmosphere incidental to radiography, may, after a period of time, be rendered sterile.

This statement was based upon discovering that ten X ray workers, who had consulted them, were the subjects of total azoöspemia, although none of them had suffered from any venereal disease or traumatism involving the genital tract, none of them presented physical signs of abnormality of these organs, and none was conscious of or gave a history of functional derangement.

Since that time the number of cases has increased and there now are records of eighteen cases in whom total azoöspemia or oligo-necrospemia has been demonstrated. All of those examined who have done extensive X-ray work for a period of more than three years show no spermatozoa in their seminal fluid, while a few of the men who have been engaged in the work for a shorter time and have exercised care in avoiding direct exposure to the active tube show varying states of oligo-necrospemia. Several cases have been examined whose exposures have been infrequent and short (once or twice a week, for from five to fifteen minutes), whose seminal fluid presents normal characteristics, with abundant actively motile spermatozoa.

These men are in robust health, and from 22 to 40 years of age. Twelve of them have operated X-ray tubes for one-half to four hours at least three times a week, for the greater part of each year during the past two to six years. Six of them are the subjects of more or less severe X-ray dermatitis of the hands.

This sterility has been produced without the slightest subjective or objective sign, illustrating its insidious development. In no case has even a transient erythema of the scrotum been noted, and in no case has there been evidence of deterioration of sexual activity. One-half of these men are married, and no one among them has had a child since he undertook this work.

Philipp<sup>2</sup> reported the exposure of the testes of two men who recognized the danger of producing sterility. One was a tuberculous subject, and he was exposed for 30 days to the rays, duration of each séance 10 to 15 minutes. At the end of this time, the semen was apparently normal, and the spermatozoa normal. Later a resection of the vas deferens of each side was performed, and six months after no spermatozoa were found in fluid withdrawn from the epididymis. This demonstrated merely a marked resistance of these organs, in this case at least, to the injurious action of the rays.

The second case was treated for pruritus ani. Total time of exposure 195 minutes. The patient then disappeared. After several months he had a slight recurrence of pruritus. Seven months later, examination

<sup>1</sup> American Journal of Surgery, April, 1905.

<sup>2</sup> Fortschritte auf dem Gebiete der Röntgenstrahlen, 1904, Bd. viii., Heft 2, p. 114.



of seminal fluid showed complete azoöspemia. Only one examination seems to have been made.

Bergonié and Tribondeau<sup>1</sup> have extended their experiments on the seminiferous tubes to the action of the rays on the spermatozoa themselves. The result was entirely negative.<sup>2</sup>

In conclusion, let me remark, while many operators say that X-ray workers after a time are permanently sterile, I am personally acquainted with six well-known active specialists in this field who during the past year became fathers of healthy children.

<sup>1</sup> Arch. d'Électricité Médicale, November, 1906.

<sup>2</sup> For a comprehensive study of this subject, the reader is referred to the following papers: Heineke—Mitteilung aus den Grenzgebieten der Medizin und Chirurgie, 1905, Bd. xiv., Hefte 1 und 2, pp. 21-94; Münch. med. Wochenschrift, 1903, No. xlviii., p. 2090, and 1904, No. xviii., p. 785; Freund, Elements of General Radiotherapy; Senn, New York Medical Record, August 22, 1903; Krause, Fortschritte auf dem Gebiete der Röntgenstrahlen, 1905, Bd. viii., Heft 3, p. 209; Halberstaedter, Berliner klin. Wochenschrift, January 16, 1905; Selin, Fortschritte auf dem Gebiete der Röntgenstrahlen, 1903, Bd. vii., Heft 6, p. 322.

## CHAPTER III

### CHANGES INDUCED IN VARIOUS DISEASED TISSUES BY THE RÖNTGEN RAYS.

THE following are the changes noted in psoriasis by X-ray exposures. We abridge the reports of Scholtz.<sup>1</sup> The diseased area was exposed to the rays from May 31 to June 6, five times, of ten minutes duration each, at 40 cm. distance. June 8, the scales had completely fallen off and the affected area was completely smooth and colored with dark brown pigment. The healthy skin in the vicinity was also slightly colored. At this time a piece of the cutis was excised containing both the healthy and the diseased tissue.

“Microscopically, the typical changes occasioned by the disease had almost completely vanished. Only the horny layer and the stratum granulosum were still somewhat thickened, and there was some infiltration of the papillæ and also around the subpapillary vessels of the corium. The epithelial cells themselves again showed the usual changes. The healthy as well as the diseased tissues were peculiarly pigmented. In one place in the corium, especially in the papillæ, were cells, some long, some stellate, with irregular nuclei, whose protoplasm was abundantly filled with round, large, yellowish-brown particles of pigment. Moreover, the cells of the rete, especially in the deeper layers, contained in their protoplasm fine particles of the same color; while a fine network of particles of pigment, lying close to each other, appeared interwoven around these cells.”

Scholtz also studied the changes taking place in lupus. A rather deep area of lupus was on the breast, which was deeply infiltrated, thickly set with tubercles, and covered with a thin crust. X-ray treatment, February 8 to March 7, at intervals, in all ten exposures, at 35 cm. distance. After a few weeks a severe dermatitis of the exposed surface appeared, with subsequent superficial necrosis. Excision March 17.

“Microscopic examination showed the epithelium in a degenerated homogeneous condition. The cutis, especially in the lupus area, was infiltrated with round cells and pus cells. The form and typical structure of the tubercles had disappeared, and were to a certain extent absorbed. In their place were collections of numerous cells, single and multiple; nucleated with swollen washed-out protoplasm; and among them mononuclear and especially polymorphonuclear leucocytes in great numbers. The giant cells contained an unusually large number of nuclei, and

<sup>1</sup> Arch. f. Derm. u. Syph., 1902, lix. p. 241.

measured 100 to 200 microns in diameter. Most of them no longer show regular outlines, but, instead, a pale, irregular mass of multinucleated protoplasm. The altered epithelioid cells, which are often polynuclear, showed the same appearance."

Grouven<sup>1</sup> gives a report of his studies of lupus of the cheek treated by the rays. He studied sections of the diseased tissue which had been continuously treated by the rays for a period of ten weeks. He noted a very large production of connective tissue, some of the fibres running through the tubercles themselves. In brief, Grouven speaks of the healing of lupus tissue as an active hyperæmia giving rise to diapedesis of the leucocytes, first observed at the periphery of the tuberculous masses, gradually extending into the interior of the tubercles. There is a conversion into spindle-cells, resulting in the complete production of new connective tissue; *i. e.*, the cells of the tubercles undergo fatty degeneration, absorption, and finally are wholly replaced by connective tissue newly formed.

Scholtz<sup>2</sup> speaks of the results of his investigations with leprosy of the nodular type, after having been treated by the rays. He exposed a leprosy area until sufficient hyperæmia was produced. He believes that "some time after the disappearance of this reaction the part of the nodule which had been treated seemed to be a little sunken, but no further change appeared. Five weeks later the nodule was excised. Microscopically, the leprosy infiltration was slightly reduced. The numerous bacilli seemed to show more granulations than the unexposed region, but were well stained and undiminished in number, the action of the rays having no apparent influence upon them." He<sup>3</sup> has also studied cases of cancer treated by the X-rays, and found that in one case he was able to obtain sections in the stage of commencing reaction, and also after the formation of a superficial necrosis. Under the influence of the rays the microscopic examination showed that the cancer cells degenerate and are destroyed. However, the degenerative processes are recognizable, especially in the deeper carcinomatous points, only after a relatively more intense action of the rays, and the appearances were very often difficult to distinguish from the normal retrogressive processes.

Freund<sup>4</sup> states that in lupus and epithelioma the improvement observed is due to cellular infiltration and proliferation, and to the influence of the rays in promoting the formation of connective tissue and cicatrices. In his opinion the X-rays possess no bactericidal qualities.

Chas. Lester Leonard<sup>5</sup> is of the opinion that the X-rays have both

<sup>1</sup>Fortschr. a. d. Gebiete d. Röntgenstrahlen, 1902, Bd. v. p. 186.

<sup>2</sup>Arch. f. Derm. u. Syph., 1902, lix. p. 241.

<sup>3</sup>Ibid.

<sup>4</sup>Lancet, August 2, 1902.

<sup>5</sup>American Medicine, October 4, 1902.



stimulating and alterative effects on normal tissue. There may be caused a retrograde metamorphosis, on tissues of low vitality, ending in fatty degeneration. He adheres in general to the tropho-neurotic theory.

The lesions in Shand's<sup>1</sup> case were recurring superficial abscesses of 18 months' standing, the pus containing the staphylococcus pyogenes aureus. Improvement began under X-ray treatment, a relapse occurring when treatment was discontinued. Irradiation was again begun and continued until a permanent cure resulted.

Rinehart,<sup>2</sup> after stating that he gets no results from X-ray treatment unless inflammatory action is induced, says: "It then remains to be decided whether the inflammation causes the death of the cancer and tuberculous deposits, or whether the effect is produced by the light itself. My own experience is, that it is the light. Simple inflammation has often been caused by caustics, in and around these sores of lupus and epithelioma, without producing the death of the process. A light sufficiently strong to produce an inflammation of the healthy cells of the part treated is of sufficient strength to destroy cells of lower vitality, as cancer cells are known to be. Whether the effect upon the skin is produced by the ultra-violet rays remains to be proven. That the low-vacuum tube produces more effect upon the skin than the high-vacuum tube, might help to substantiate the statement that the effect is from ultra-violet rays, as they are given off more freely from the low-vacuum tube."

Hallopeau and Gadaud<sup>3</sup> call attention to the sclerogenic action of the X-ray, to which they properly attribute the unguinal dystrophics and the vascular dilatation produced thereby.

Herzog<sup>4</sup> treated transplanted sarcomas in two rats. The skin over the tumor became necrotic in each case. In one, the tumor changed to a cyst filled with a perfectly clear fluid material, and after the fifth exposure the whole tumor came away, leaving a clean surface.

Walker<sup>5</sup> has studied sections of rodent ulcer healing under treatment by the X-rays, and describes the new growth as undergoing fibro-myxomatous degeneration.

Blackmar<sup>6</sup> concludes that the X-rays cause a breaking down of malignant and non-malignant growths, the disintegrated material being absorbed. He considers the waste products from a rapidly disintegrating cancer exceedingly dangerous when thrown into the general system, unless the patient is in vigorous health.

<sup>1</sup> Australasian Med. Gazette, May 20, 1902.

<sup>2</sup> American Journal of the Medical Sciences, July, 1902.

<sup>3</sup> La Presse Méd., July 16, 1902.

<sup>4</sup> Journal of Medical Research, June, 1902.

<sup>5</sup> British Med. Jour., May 10, 1902.

<sup>6</sup> American Electrotherapy and X-Ray Era, May, 1902.

Morton<sup>1</sup> believes that the effect of the X-rays in the cure of disease is due to a primary chemical reaction, affecting in turn the metabolic processes. He claims that under proper conditions the X-rays build up tissue, in proof of which he cites the case of a young woman suffering from enlarged axillary glands. In six weeks, the neck, shoulders, chest, and breast of that side had developed so markedly that the patient afterward desired the opposite side treated in order to restore symmetry.

Beck<sup>2</sup> states that an adeno-carcinoma, subjected to the X-ray treatment, showed beginning colloid degeneration, changes of the same nature being observed in the epithelium of the skin covering the tumor. Specimens of the affected skin showed thickening of the intima of the small blood-vessels; fibrous tissue in reticular arrangement being deposited. The same observer elsewhere states that he regards as most important, the nutritive changes in the walls of blood-vessels and the results incident to such changes.

Loeb,<sup>3</sup> after seven exposures of ten minutes each during eleven days, transplanted sarcoma in a rat and found mitoses in the cells. The tumor continued to grow, and pieces from it were successfully transplanted into other rats. Degenerative changes were present in the centre of the tumor, but Loeb believes that these changes occur in many tumors without exposure to the rays.

A. G. Ellis,<sup>4</sup> in regard to tissue changes, occasioned by the X-rays, reports upon the findings in four cases, which were carefully examined. He observed necrosis of cells and trabeculæ of a varying degree. There was also marked fatty degeneration. In three cases there was increase of elastic tissue before and after exposure. In one case there were fewer areas of lymphocytic infiltration after exposure, and about equal numbers before and after in others. A tendency to occlusion of the vessels, by deposits on their inner surfaces, was marked in some cases. Entire absence practically of infiltration of polymorphonuclear leucocytes was noted. These findings, he remarks, hardly warrant conclusions, but a few thoughts suggest themselves. The blood-vessel changes, on which Beck and others lay stress, seem hardly to account for the accompanying tissue necrosis, though endarteritis is probably induced by the X-rays. He thinks the possibility is suggested of their being similar lesions from the same influence instead of standing in relation of cause and effect. The presence of immense numbers of cocci and bacilli in the tissues in one case after twenty exposures, would argue against the bactericidal power of the rays. It should be said, however, that the pathogenicity of these organisms was not proven.

<sup>1</sup> Medical Record, May 24, 1902.

<sup>2</sup> New York Med. Journal, May 24, 1902.

<sup>3</sup> Journal of Medical Research, June, 1902.

<sup>4</sup> A. G. Ellis, in American Journal of the Medical Sciences, January, 1903, from which many of the above statements have been taken.

Vose and Howe,<sup>1</sup> from a study of the effects of X-rays on cancer, believe that, "Cutaneous cancer treated by the X-rays undergoes degeneration not peculiar to this form of treatment or distinguishable histologically from degeneration from other causes. The vascular changes are limited to an endarteritis; new formation of blood-vessels occur, if healing takes place, as in the process of repair elsewhere; there is an increase of elastic tissue. Taken as a whole, the clinical cases show that the only cure of cancer by the X-ray is by destruction and exfoliation. This at once limits its value to superficial cases. This destructive process is a slow one, and acts very superficially."

<sup>1</sup> Journal of Medical Research, Boston, January, 1905.



## CHAPTER IV

### TECHNIC OF RÖNTGEN RAY THERAPY.

THE production of a dermatitis, the result of the use of the X-rays as a diagnostic measure, early suggested the possible value of the new agent for therapeutic purposes. Treatment with the X-rays depends largely upon the character of the lesion. Thus the same method of treatment would be of no avail if applied indiscriminately to the malignant and benign, to the superficial and to the deeper tissues, etc. Effective technic in treatment is dependent not only upon a good understanding of how to use effective apparatus accurately, but also upon the experience and ability of the operator to apply, to each individual case, the quality and dose that that particular case demands.

In observing the progress of disease, so far as a cure is concerned, and also for comparative study of several diseases, a life-sized photograph of the affected area should be taken before the actual treatment is commenced. The plate employed should be isochromatic in type, in order that the color value of the tissues may be recorded as exactly as possible. To be accurate all these photographs should be taken in precisely the same manner. The prints made from the resulting negatives should be of equal density.

When an open wound is to be treated, care must be exercised not to infect it; if it is well protected by a sterile dressing, this should not be removed, unless ointments are smeared thereon which might offer obstruction to the rays, such as zinc oxide, boric acid, bismuth, iodoform, etc. I would urge that all lesions be covered with several layers of gauze while treatment is in progress.

#### I. Apparatus and Method of Treatment.

The apparatus necessary for intelligent and effective treatment is practically the same as that employed for skiagraphic purposes. The current for exciting a tube is generated by a static machine, an induction coil of the Ruhmkorff type, or a Tesla high-frequency apparatus. Some operators prefer the static machine, believing that it does not produce a dermatitis, but this has been proved a fallacy. Regarding the size of the coil for therapeutic purposes, one that is of seven or eight inch (18 to 20 cm.) spark producing power will suffice.

When using a coil for therapeutic purposes, the frequency of prolonged exposures, often required, is liable to injure the insulation of the coil. It is considered advisable to switch off the current and allow the coil and the tube to cool every ten or fifteen minutes, during prolonged

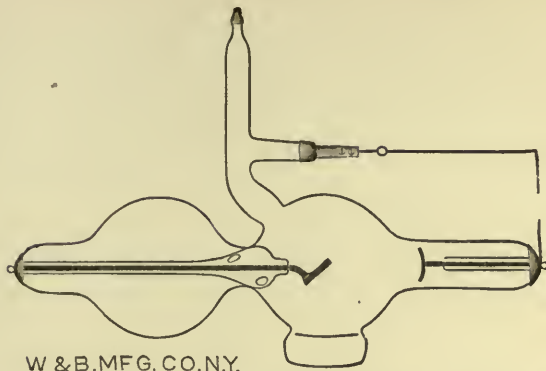

W & B. MFG. CO. N.Y.

FIG. 211.—PIFFARD TREATMENT TUBE.—The whole tube is made of lead glass, except at the lower opening, to permit the passage of the rays for therapeutic purposes. This is a protective measure for the operator, and also limits the area irradiated.

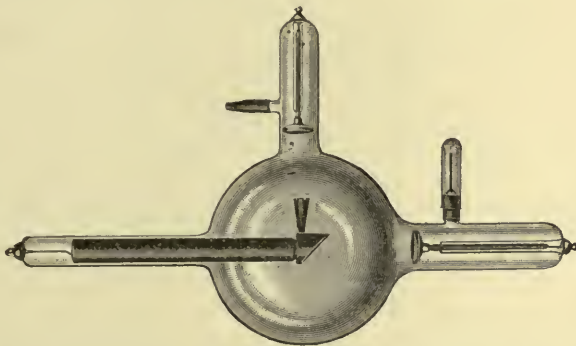
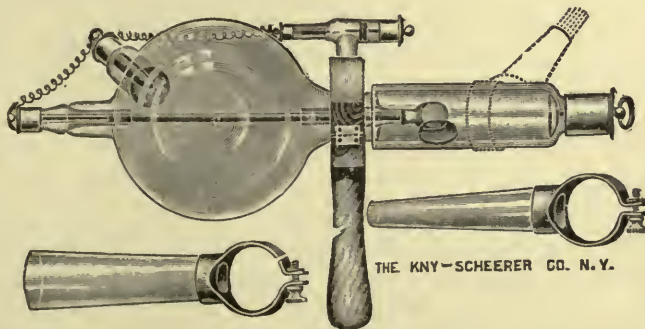

FIG. 212.—THE BI-CATHODE TUBE OF KOCH OF DRESDEN.—Koch asserts that where much inverse current must be overcome, this tube acts both as an X-ray and a ventril tube. He believes that, the anode being of a heavy design, a large quantity of current may be employed with a shortened exposure. (Kny-Scheerer Co.)



THE KNY-SCHEERER CO. N. Y.

FIG. 213.—THE KNY-SCHEERER TUBE.—The anode is placed into the tubular extension, the latter being encased by a cylinder of lead-flux glass. A set of two specula of lead glass further serve to localize the X-rays.

treatment; but, the current being of small amperage, the injury to the coil at most would be slight. The mechanical or the liquid interrupter may be employed, but the mechanical, being the cleaner and easy of manipulation, is commonly used. The electrolytic interrupter has met with little favor, as the enormous current transmitted to the primary is totally unnecessary, and is detrimental to the life of the tube and the coil.

#### CROOKES TUBE.

The tubes employed for therapeutic purposes (Figs. 211, 212, 213, and 214) are practically similar, in degree of vacuum, to those employed for diagnostic purposes. They are self-regulating, or those in which the vacuum can be altered by automatic appliances. Tubes are also classified according to their degree of vacuum, as "soft," "medium," and "hard." The rays coming from a tube of low vacuum produce an early and rapid

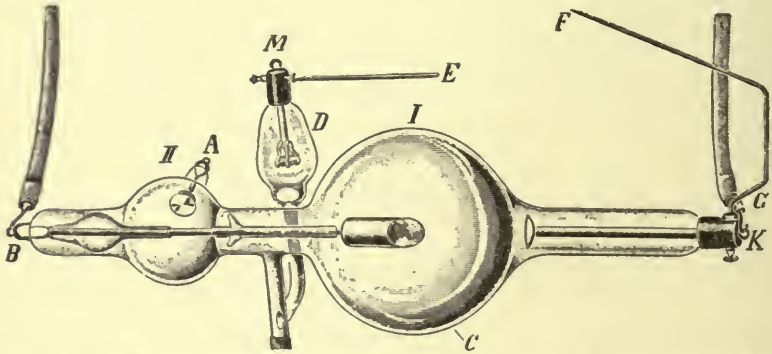

FIG. 214.—Dr. J. Ronsenthal's tube for therapeutics, as employed by him in the hospitals of Munich.

tissue change. When a softer tube is employed more tissue change results, because under such conditions the rays are considerably less penetrating and more readily absorbed by the tissues, than with a hard tube. This is the accepted view of most X-ray operators. When the suspected lesion is deep-seated, as in cases of carcinoma of the uterus, stomach, or abdomen, a "medium" tube should be used. The connection of the Crookes tube with the oscilloscope is explained at Fig. 215.

#### PROTECTION OF HEALTHY PARTS.

Prior to the application of the rays (as in cases of superficial ulcers, epithelioma, etc.) the surrounding normal tissue should be protected against the influence of the rays. This may be accomplished by shielding the surrounding integument by leaden sheets,  $\frac{1}{2}$  of an inch (1 mm.) in thickness, covered with adhesive plaster, and grounded, in which an aperture has been cut, to permit the passage of the rays. The aperture should be of the same size as the superficial lesion. This



precaution, however, does not apply to lesions that are deep-seated, the risk of setting up an integumentary inflammation weighing but little in comparison with the gravity of the condition.

An ingenious device is the protective tube shield, which conforms to

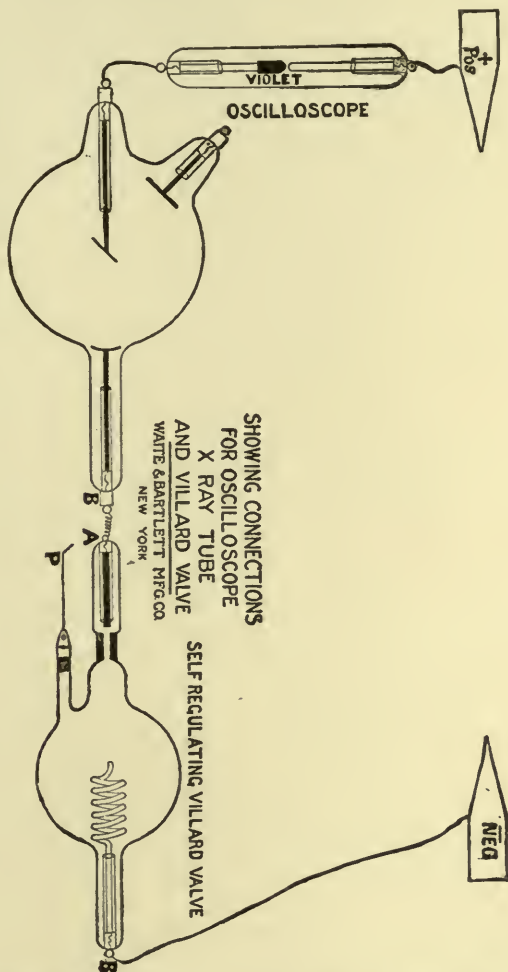

FIG. 215.—CONNECTION OF THE TUBE AND VILLARD VALVE WITH THE OSCILLOSCOPE.—Piffard, of New York, uses the oscilloscope as an index of the inverse current. When the inverse current is excessive, a violet glow will appear on both terminals of the oscilloscope; if the current is unidirectional the glow will be manifest only on one terminal of the oscilloscope. The oscilloscope is in reality a Geissler bulb.

the size and shape of the Crookes tube, and is provided with different sized cylinders, or localizers, allowing either a large or small surface to be acted upon by the rays.

## POSITION.

The position of the tube is of little importance, except that the anodal field must face the lesion. The satisfactory application of the rays to such conditions as carcinoma of the cervix uteri, diseases of the oral cavity, the larynx, stomach, and rectum is a matter of much difficulty. If the tube is placed within a cavity, or in such a position as to send the rays directly to the seat of the lesion, better results are to be expected than if the rays need penetrate some intervening tissue. For this reason tubes of special shape have been designed by Caldwell of New York, and Cossar of London, for the express purpose of treating diseases of the rectum, vagina, and oral cavity. The tube devised by Caldwell has a long cylindrical projection which fits into a metallic protector. The latter has an opening which corresponds to the area undergoing treatment. The Cossar tube is constructed of lead glass comparatively opaque to the rays, except at the end of the projection, which is made of ordinary glass, and permits the rays to reach the diseased area only.

## DISTANCE OF THE TUBE.

The distance of the tube from the part depends upon the quality of the tube, upon the size of the area to be treated, and whether a rapid reaction is desired or not. It is measured from the target of the tube to the exposed surface. The nearer the tube, the more intense the action. Theoretically, some claim that the distance of the tube from the part should be directly as the height of its vacuum and inversely as the distance of the part to be affected is from the surface. Some operators prefer a short distance with short or less frequent exposures. This I believe to be a matter of personal experience, and can only be determined by a most careful study of each and every case seeking treatment. The anode of a hard tube should usually be placed from twelve to fifteen inches (30 to 38 cm.) from the surface, and a soft tube from six to eight inches (15 to 20 cm.). On the other hand, the tube should be placed nearer to the body, the farther the diseased part is from the surface.

Dr. William S. Newcomet<sup>1</sup> has devised a frame covered with lead, containing openings in three of its sides, and employed by him for X-ray therapeutics. The sizes of these windows may be modified by the insertion of few or many lead diaphragms. The Crookes tube is placed within the frame, with the active hemisphere directed towards the openings. As three patients can always be treated simultaneously, much time is saved by this device. But patients must be selected that demand the same quality of the rays, as exemplified in large hospitals.

<sup>1</sup> American Medicine, March 5, 1904.

Dr. H. P. Wells, of St. Louis, has very kindly sent me the following description of his ingenious method, for the multiple connection of Crookes tubes in series, as a means of economy of time and current.

"It has been found practical," he writes, "to connect in series more than one Crookes tube to be operated from a single coil or static machine, and thereby increase the usefulness of such equipment to meet the needs of those doing much clinical work and with whom the question of time and expense are matters of consideration.

"The tubes are connected so as to maintain the proper direction of flow of current in both of them, that is, the anode-terminal of one tube is connected to the cathode-terminal of the second, etc.

"It is hardly practical to use more than two tubes on the average coil or static machine, as the resistance and consequent strain on the machine increases by arithmetical progression with the number of tubes in the circuit.

"It is possible to maintain each tube at any desired resistance by adjusting the shunt spark-gap on the regulating device of the tube, each tube regulating itself independently of its fellow.

"The only apparent difficulty in the way of the multiple connection of the tubes, is the strain thrown on the interrupter, especially of the mercury jet type. I believe that a perfected form of mechanical interrupter will prove least troublesome and give the best results under the higher resistance in the secondary.

"Economy of current is effected, because we use the latter in the second tube, which ordinarily is dissipated in the form of heat in the rheostat when only one tube is used."

This method has also been employed in the London Hospital, where they also run a series of coils from the same interrupter and on the same primary current.

#### THE DURATION OF EACH EXPOSURE.

This depends on whether a coil or static machine is used, and upon the patient's susceptibility and the character of the case. Operators differ in the length of time of exposure. Some resort to frequent but short exposures with ascending doses, others employ longer but less frequent exposures. If the integument remains normal, the séances are lengthened, twenty minutes being the maximum. All other things being equal, the usual time of exposure with a coil is less than with the static machine.

#### FREQUENCY OF THE EXPOSURE.

This depends upon the character of the lesion, the rapidity of action desired, the length of each exposure, the susceptibility of the patient, and on the distance of the tube. At the very beginning of treatment,



it is advisable to expose the patient two or three times a week for the first two weeks, and then to discontinue treatment for a similar period, watching in the interval for the development of any untoward symptoms. Some prefer to give a treatment every other day, asserting that this procedure is productive of the best results. This necessitates very close watching of the patient's susceptibility, but if caution is observed not to over-expose the seat of disease, then the applications may be brought more closely together for almost an indefinite length of time. Periods of rest for tissue restoration, other than that just mentioned, should never be attempted, as under this plan all is lost that may have been gained through the treatment of the previous days or weeks.

#### FILTERS.

Concerning the law of the absorption of the Röntgen rays, Walters<sup>1</sup> finds that, after these rays pass through silver, palladium, cadmium, zinc, and antimony, they are soft instead of hard. In other words, these metals absorb the hard rays, while aluminium, copper, and the metals at the extremes of the scale of atomic weights absorb the soft rays. The second layer of any specified substance absorbs less rays than the first. This principle, he believes, can be applied practically in interposing a substance similar to the skin in the treatment of deep-seated growths without sacrificing the skin.

Drs. G. E. Pfahler and J. F. Schamberg<sup>2</sup> conducted a series of experiments upon rabbits, in which use was made of silver, leather, and aluminium, for the purpose of establishing their values as filters. They found leather of decided advantage for filtering out the soft, medium, and hard rays. They were impressed with the fact that the susceptibility to the rays varied in different animals, which doubtless is also true of man. It has been my practice for some time past to employ aluminium and leather filters, but I decidedly prefer the former.

#### THE DOSAGE.

By "dosage" is meant the quantity and quality of the Röntgen rays used during each exposure. This depends upon whether the condition is superficial or deep, malignant or benign. Some believe in exposing the part until tanning or bronzing occurs, but in dark-skinned individuals, in negroes, and in mucous membranes no tanning is observed; hence in these instances this sign cannot be depended upon. I have noticed that itching often indicates the beginning of a reaction within the tissue. If the treatment is continued after the development of these signs, erythema, vesication, or dermatitis may develop, whereupon the

<sup>1</sup> Fortschritte auf dem Gebiete der Röntgenstrahlen, Berlin, April 13, 1905.

<sup>2</sup> Journal of the American Medical Association, September 15, 1906, p. 888.

operator should cease treatment. These effects do not necessarily mean carelessness on his part and may occur in most skilful hands.

Although the clinical manifestations are a guide in determining the amount of reaction obtained, yet they do not indicate the exact amount of the X-rays used. The possible methods of determining the "dosage" are fully detailed and discussed in a special section.

## II. Methods of Measuring X-Ray Dosage.

Since Röntgen's discovery, scientists have lacked a practical and exact unit of X-ray dosage. The establishment of a standard unit is difficult, because of the idiosyncrasy of the patient, and because no one can make any positive statement as to the number of treatments that any one case may demand, the personal equation entering so largely into the consideration. We cannot deduce the amount of physiological and biological action of the rays on the tissues by the measurement of their chemical and physical properties. The question arises: What standard shall we adopt, so that the unit may be accurate, practical, and precise? Recently the Röntgen Ray Society of London appointed a committee for the purpose of formulating a standard unit for the measurement of all radiations; they arrived at no definite conclusion and asked for the earnest coöperation of American scientists.<sup>1</sup>

### A. MEASUREMENT OF ELECTRIC CURRENTS.

*The Current going to the Primary Coil.*—The voltage and amperage of a current that goes to a coil depends upon the variety of the interrupter and the construction of the primary coil. The secondary or induced current depends upon the variety of the current or winding of the coil, because the same coil and interrupter may give a different quality of the rays, depending upon the make and the vacuum of the tube. Wertheim Salomousson's experiments show that electric energy is absorbed in the rheostat and in the interrupters. Wehnelt considers that 30 to 80 per cent. of the energy derived from a battery is absorbed by the electrolytic break. Salomousson's wattmeter showed that 61.2 and 65.4 per cent. of current was lost. Since this percentage of lost energy evidently varies under different conditions of operation, it follows that the induced secondary current is not proportional to the primary current when an electrolytic interrupter is used.

*Milliamperage of the Secondary Induced Current.*—The milliamperemeter was first advocated by D'Arsonval, who used it with a Villard tube, and proved that the production of X-rays is proportionate to the intensity of the current, and has shown photographs in support of this

<sup>1</sup> At a meeting of the American Röntgen Ray Society held at Niagara Falls, August, 1906, I urged the appointment of a committee to confer with a like committee of the Röntgen Ray Society of London, which was agreed to.

assertion. The milliamperemeter measures the current passing through a tube; but does not tell us how much energy is expended in the production of the rays.

Salomonson asserts that X-ray production is a function of watts expended in the tube rather than of the current traversing it. If his theory is correct, and I believe that it is, then we should know the amount of energy or watts expended in heating the anode.

The milliamperemeter measures the resistance of the tube. There are degrees of vacuum where no X-rays are produced, yet the milliamperemeter indicates a passing current. The resistance of a tube often depends upon the shape and angle of the anode (platinum), upon the surface of the cathode, and upon the focal distance of the cathode. A valve tube makes the current unidirectional, as shown by the oscillograph; the latter also shows absence of constant movement in the needle, whilst the milliamperemeter shows the slight changes in the vacuum by the deflection of the needle. It should never be forgotten that the reading of the milliamperemeter is not necessarily an absolute index of the amount of X-ray production in the tube. Thus, we read the milliamperage and we know that the current is passing from the secondary into the tube; but how much of the current going through the tube is expended in the production of the X-rays? So much depends upon the make, shape, size, etc., of the tube and upon the relation existing between the cathode and anode that the answer is difficult, if not impossible. However, Salomonson<sup>1</sup> described and exhibited a new instrument for measuring the energy of a variable current of high potential. The milliamperemeter usually used for measuring the current in the secondary circuit indicates the mean current, whereas what we really require is the *mean square* value, and with an oscillating current these two values are not proportional.

The dilatometer devised by Professor Salomonson measures the energy expended in the secondary circuit directly. It consists of a paraffin oil thermometer, which is heated by the current passing through a slate resistance. Slate has a high and fairly constant electric resistance. The heating effect of even a small current is therefore readily appreciable. The heat is communicated to the surrounding paraffin, and the consequent expansion in the paraffin is shown in a capillary tube attached to the vessel. The rise of the meniscus in this tube will therefore be a measure of the total energy expended in the circuit during the time the current has passed through the resistance. The dilatometer sums up the values of the energy for each instant since the current was started; its readings will therefore be proportional to the mean square of the current, and the rise of the meniscus per unit time will give the mean square intensity of the current. The dilatometers are standardized by means of

<sup>1</sup> Archives of the Röntgen Ray, April, 1906.



an electro-dynamometer and a stop-watch, a small steady current being passed through the two instruments.

Experiments with these instruments showed that the efficiency of a Ruhmkorff coil is the same for all intensities of current in the primary, *provided that the resistance in the secondary circuit remains unaltered.*

*Spintermeter.*—Measuring the length of the spark-gap (parallel) on the secondary coil or induced current was the earliest method employed. The length indicates the internal resistance of a tube to the passage of the current; the longer the spark-gap the higher will be the vacuum. But it is a fact that the variation in the supply of current in the primary coil or interrupter will change the length of the spark-gap, with the same tube in circuit. The pointed rods of the electrodes, the composition of the rods, the atmospheric conditions, such as moisture, etc., the construction of the coil, interrupter etc., the source of current and also the amount of the current, will alter the length of the spark-gap. Two different tubes with the same current and same spark-gap may give different degrees of radiation, because the size of the electrodes may be different and different metal may be used, etc. Bécélère, of Paris, employs a graduated rod capable of sliding to and fro. On this sealed bar he observes the number of inches or centimeters. This is a convenient form of measurement, and every coil is thus supplied and is universally employed. This method is often misleading, as I have seen a tube with 3- or 4-inch (7.5- or 10-cm.) spark-gap, where the rays were far less penetrating and in some instances cathodic rays were produced.

The data given by the spintermeter holds good only for the special apparatus that the operator employs and not necessarily for other forms of this apparatus.

## B. THE PENETRATION METHOD.

By this means we measure the penetrative property or quality of the rays directly outside of the tube.

*The Radiochromometer of Benoist* (Fig. 216).—M. L. Benoist devised this instrument, which is based upon the principle that different metals possess different degrees of transparency as regards their penetration by the X-rays. A silver disk in the centre of this device having a thickness of 0.11 of a millimeter, is used as standard. Around this disk are placed layers of aluminium, beginning with one layer and up to 12, like the dial of a clock. These 12 sectors are designated by lead numbers, so that one can recognize them by their position without seeing the number. This apparatus can be used either with the fluoroscope or on a photographic plate. One of the sectors will match the tint of the central disk. A lead diaphragm is provided for bringing one sector into view, and the diaphragm is then rotated until the tint of the sector corresponds to the tint

of the centre. M. Benoist<sup>1</sup> improved upon this apparatus. His device resembles a telescopic arrangement, whereby the numbers and the tints on the screen appear enlarged; it is also furnished with a glass to protect the operator while testing the rays. By rotating the lead diaphragm one can examine each sector successively. Dr. Geo. Pfahler<sup>2</sup> places a mirror

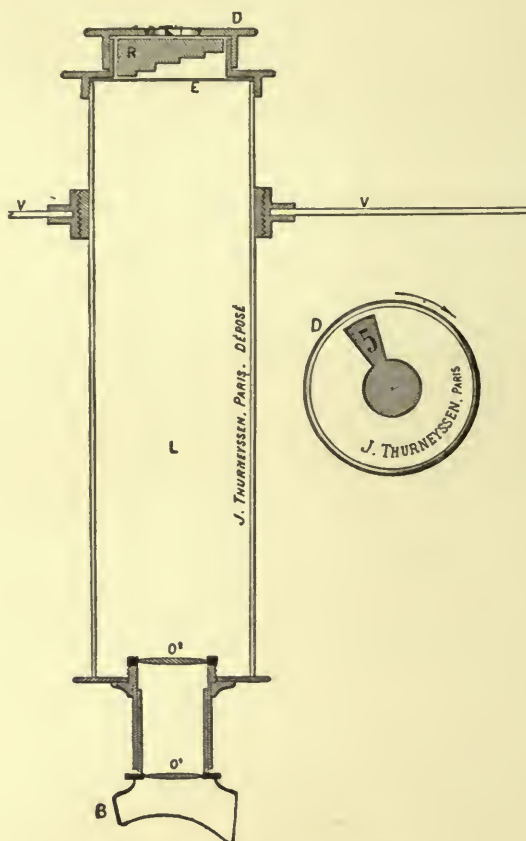

FIG. 216.—Benoist's radiochromometer.

at an angle of 45 degrees, utilizing the principles of the reflecting fluoroscope (Figs. 217, 218), thus preventing the rays being directly projected upon the face or hand, and in this way minimizing the danger of burns. Dr. Lacaille<sup>3</sup> has devised an apparatus which is simply a Benoist radiochromometer associated with a lunette, of similar disposition to that used

<sup>1</sup> Archives d'électricité médicale, April, 1906.

<sup>2</sup> Archives of Physiological Therapy, June, 1906.

<sup>3</sup> Bulletin Officiel de la Société Française d'Électrothérapie et de Radiologie, July and August, 1905.



FIG. 217.—The improved benoist radiochromometer.



FIG. 218.—The same, with its parts connected.

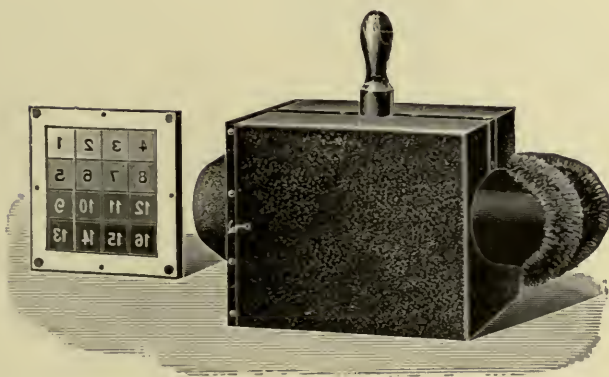

FIG. 219.—The skiameter.





by Brandt in his posometer. Such a lunette is formed of two parts: a box 6 x 8 x 10 centimeters and an eye-piece placed close to it at an angle of 45°. The box in his apparatus presents two interesting points: (1), on the bottom and placed at an angle of 45° is a mirror in which, when looking through the tube, one can see the inferior surface of the upper wall of the box; on said inferior surface is affixed a pasteboard disk covered with barium platino-cyanide; (2), on the superior surface of the same upper wall, exactly above the platino-cyanide disk, is the radiochromometer, the shade of which is projected by the X-rays on the little screen, and reflected in the mirror. With such a disposition the operator is not directly exposed to X-rays.

All radiochromometers give only penetration power, but we know that there is a great difference between the penetration and fluorescence, and also between photographic (chemical) and physiological (therapeutic) effects.

*Skiameters and Penetrometers.*—The principle of these devices consists in the use of an obstacle to the passage of the rays. (Fig. 219.) Many different metals have been used to determine the penetrative power of the rays, but as with Benoist's device these forms of apparatus do not indicate the intensity of the rays. Two different tubes which have the same penetrative power may differ in their chemical and physiological effects.

*Crypto-radiometer of Wehnelt.*—This apparatus (Fig. 220) consists of a fluoroscope with a sliding or telescopic arrangement and provided with a sheet of lead to protect the hand of the operator and a single "V"-shaped piece of metal which gradually increases in thickness.

It is claimed by Wehnelt that his apparatus is more accurate and allows of a wide range of comparison because of the wedge-shaped character of the piece of aluminium.

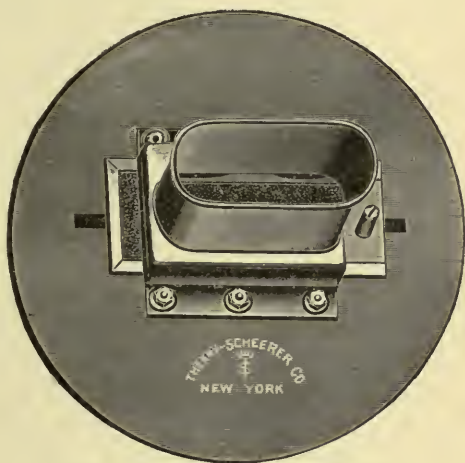

FIG. 220.—Crypto-radiometer of Wehnelt.

### C. THE PHYSICO-CHEMICAL METHOD.

Because of its accuracy and precision, I believe that physico-chemical measurement more nearly approaches the ideal than the other procedures in vogue. This method has been ably illustrated by Holzknicht. He

based his theories and constructed his apparatus upon the principle that certain salts suffer a change of color when exposed to the cathode rays. Other substances, when heated and irradiated, undergo a change of color, as the chloride of lithium, which becomes a greenish-yellow, and carbonate of potassium, which changes to a heliotrope. On exposure to the air, or at a high temperature, the colors of these salts are seen to disappear. He also proved that X-rays and Becquerel rays possess this property, and that they are all transformed into ultra-violet rays at the point of impact with the surface.

*Chromoradiometer of Holzknrecht.*—Guido Holzknrecht, of Vienna, presented this device for the consideration of the profession in 1902. Holzknrecht's studies on this subject led him to fuse certain salts and to expose them to the action of the rays. He employs a small capsule containing the reagent covered with celluloid. This reagent, which is colorless and whose composition has heretofore been kept a secret, has been analyzed by a French chemist, Mr. Lind,<sup>1</sup> and M. Bordier describes it as follows: "The reagent consists of 99.77 per cent. potassium sulphate, the remainder being potassium sulphite or hyposulphite, or possibly potassium tri-, tetra-, or penta-thionate. The mixed mass is impregnated and held together with copal varnish. This capsule (which is placed over the cutaneous area to be treated) has a dirty-yellow color due to the copal varnish, and under the influence of the X-rays the color changes to a greenish tint, gradually becoming deeper as the quantity of the rays is increased. After, or often during, the irradiation this capsule is brought near to a standardized scale which is graduated in Holzknrecht units, from 1 H. to 24 H., the color scale being graduated from a greenish-yellow to a deep green, which serves as a standard of comparison for judging the color of the capsule after irradiation. The unit is indicated by H. This method has certain disadvantages: The treatment is interrupted in order to compare the color of a reagent with that of the scale, and this is repeated until a tint is obtained which corresponds to the precise dose required. As more than one sitting may often be necessary (in the interval between the two exposures), this reagent must be kept in darkness. This graduated scale holding the numbered capsule is kept in a light-proof box. Although this method would seem very correct in theory, nevertheless, in practice we meet with many difficulties. The standard scale suffers changes in color, or it may fade in the course of a year. Subsequent to exposure the capsule gets darker and must be compared immediately. The comparison of the capsule with the scale is very difficult. Different individuals and different parts of the body exhibit different degrees of susceptibility, and the various diseases display individual peculiarities to the action of the rays.

*Radiometer of Sabouraud and Noiré.*—In 1904 Drs. Sabouraud and Noiré introduced a method largely employed in France. It consists of a

<sup>1</sup> Archives of the Röntgen Ray, June, 1906, p. 6.



small disk of paper over which is spread a layer of platino-barium cyanide; this salt assumes a brown color under the action of the X-rays. M. Villard pointed out that under the influence of increasing doses of the rays, platino-cyanide passed from a bright green to brown, and at the same time the fluorescence gradually decreased. Upon a two-page leaflet is the standard-color pastille, marked "A" (which is an unchanged green color), and another one marked "B," which is brown, and indicates the maximum dose the skin can tolerate without producing dermatitis, and causing only epilation. The comparison should be done in a dimly lighted room, because, if the pastilles are exposed for too long a period to the light, they regain their original green color. The pastille should be placed in a pastille-carrier, 8 cm. from the anode, and midway between the part under treatment and the anode. The standard color pastille "B" corresponds to a dose of 10 X, or 5 H in Holzknacht units. Sabouraud himself admitted that the test, however, is less sensitive than by the Holzknacht method, and that the color may change by the action of heat, light, moisture, etc. It is asserted by some that the location where the pastille is placed under the active hemisphere may not be equally irradiated, because the rays are unequally distributed over the active hemisphere.

*The Chromoradiometer of Bordier.*—Bordier<sup>1</sup> describes a new method, based on the principle that when platino-cyanide of barium is exposed to the rays, it undergoes a change of color due to the dehydrating action of the X-rays, also that the same discoloration occurs when this chemical is placed in an atmosphere artificially dried by sulphuric acid or when exposed to a gradually increasing temperature. Under the action of light dehydration may also occur. He describes his apparatus and reagent as follows: "The Bordier chromoradiometer differs from its predecessors. The barium-platino-cyanide, suspended in a thin layer of collodion, is placed on the skin itself, or at all events in the same plane as the part to be irradiated. The pastilles are square, with a diameter of 6.5 millimetres. The back of the square is adhesive, to facilitate its attachment to the skin. A scale of colors is supplied with tints Nos. 1, 2, 3, 4, corresponding to the principal reactions required in radiotherapy.

"Tint No. 1, a pale yellowish-green, is the shade that the pastille takes when exposed to the maximum dose of rays compatible with the complete integrity of the normal skin. With this dose of X-rays the hair falls out some twenty days after exposure, and grows again within the succeeding twenty days. This is the weak normal exposure of Kienböck's, corresponding to a skin reaction of the first degree, accompanied by temporary loss of hair.

"Tint No. 2, of a sulphur-yellow shade, is that color the pastille assumes when the skin has been exposed to an irradiation calculated to

<sup>1</sup> Archives of the Röntgen Ray, June, 1906, p. 9.

produce a strong reaction, *viz.* erythema, tumefaction, and at the end of the reaction marked desquamation. This No. 2 tint corresponds to a mild form of Kienböck's reaction of the second degree.

"Tint No. 3 is almost of the color of gamboge. It corresponds to a reaction of the skin of the second degree; it is a true dermatitis. Latent period is eight to ten days. This is Kienböck's strong normal reaction.

"Tint No. 4 is of a chestnut color, and corresponds to a reaction of the third degree, which is accompanied by necrosis and ulceration of the skin. This is the strongest dose ever required and should never be applied to the normal skin. He obtained tint No. 4 after irradiation of a specimen of radium of a radio-activity of 100,000 for a week, at a distance of a millimetre from two pastilles."

Very soft tubes are not desirable for these reagents, as they produce ultra-violet rays which will be confused with the X-rays. He reports cases that were cured at a single séance. He believes in giving one massive dose rather than fractional doses, so common in this country. This method is also subject to the same objections that I have mentioned before.

*Quantimeter of Kienböck.*—In 1905 Dr. R. Kienböck introduced this new method of direct dosimetry, and asserted that, in 1900, he demonstrated that the changes noted on a photographic plate are an accurate measure of the therapeutic dose; admitting,<sup>1</sup> however, that Stern<sup>2</sup> published a paper on photo-radiometry, and suggested the use of photographic films, to be compared with a "normal scale;" but at that time (1905) Kienböck was unaware of the fact. He describes his instrument as follows:<sup>3</sup> "My quantimeter (Fig. 221) consists essentially of two parts, a strip of photographic paper, which is easily applied to the irradiated skin, and a normal scale of graduated tints, with which it is to be compared. The paper is covered with a sensitized film of chloro-bromide of silver in gelatine. After exposure, the strip may be developed in a dark room or by means of a small light-proof box. The development can be carried on in daylight in the consulting room. The film is then compared with the standard scale, either at once or after drying. The developing solution is of constant composition, and should be used at a temperature of 18° C., or 64° F., for a period of exactly one minute. After fixation, the strip of paper may be immediately compared with the scale." The unit of Röntgen light which we call X is equivalent to one-half of a Holzknecht unit and to one-tenth of the Sabouraud-Noiré maximum dose. The formula is as follows: 1 S-N maximal dose = 5 H or 10 X.

This reagent enables us to measure the penetration or the degree of hardness of the Röntgen light. In comparison with other dosimetric

<sup>1</sup> Archives of the Röntgen Ray, June, 1906, p. 17.

<sup>2</sup> Journal of Cutaneous Diseases, December, 1903.

<sup>3</sup> Archives of the Röntgen Ray, June, 1906, p. 17.

methods, the quantitative method has the advantage of greater exactness and the possibility of estimating small differences of dosage. This method gives a permanent registered record. The disadvantage of this method is the difficulty which is encountered in comparing and distinguishing the slight differences of tint on the scale. Careful development is necessary and always tedious. When massive doses are given the color will be darker and will be more difficult for making comparison with the scale. The degree of the sensitiveness of the emulsion of the paper may frequently differ.

*The New Radiometer of Freund.*—Freund's method was used in 1904, and is based on the color changes occurring in a two per cent. solution of

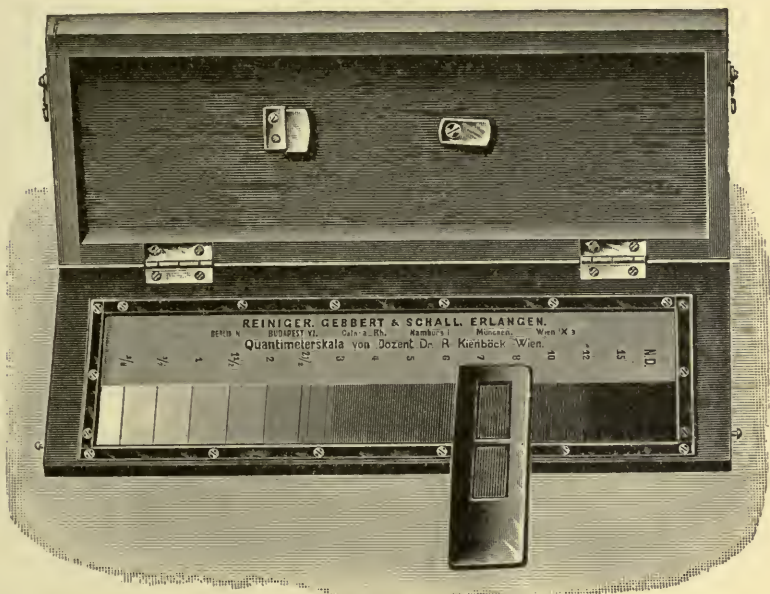

FIG. 221.—Kienböck's quantimeter.

pure iodoform in chloroform. This solution normally retains its color unchanged for 48 hours, and is so very sensitive that a difference of tint may be observed between two portions of the solution, one of which is exposed to the rays for three minutes, while the other portion is screened from the action. Slight heat and light will alter the color of the solution, and, although this method is most accurate and sensitive, the solution is too unstable for practical and clinical purposes.

The iodoform ( $\text{CHI}_3$ ) is decomposed by the X-rays, with the liberation of free iodine, imparting a claret-color to the solution. Freund's solution shows a change of tint in six minutes, equal to that attained in ten minutes by the use of Holz knecht's pastilles.



*Precipitation Test.*—Schwartz,<sup>1</sup> of Vienna, demonstrated a method of measuring the strength of the Röntgen rays, based on the precipitation of calomel in a mixture of ammonium oxalate and corrosive sublimate. This mixture is a clear fluid which, sheltered from the light, keeps indefinitely. Exposure to daylight or to the Röntgen rays causes the precipitation of calomel. The amount of precipitation is determined by centrifuging in a graduated capillary tube. Three millimeters of the precipitate in the capillary tube correspond (approximately) to the strength of a Holzknicht unit. This technique with the usual methods of testing the strength of the latter has the disadvantage of being a subjective test of color.

#### D. THE IONIZATION METHOD.

Prof. Röntgen, in his second announcement, stated that he had already made this discovery, and, probably prior to this, J. J. Thomson found that the X-rays would discharge both positively and negatively electrified bodies, by experiments on Hankel's electroscopes or electrometer. Thomson stated that the discharge varied somewhat with the intensity of the rays by the relative luminosity of the fluorescent screen, and in several instances by the relative darkness produced upon the photographic plate. This method is based on the principle that X-rays have the power to ionize the gases through which they travel.

*The Ionization of Confined Gases.*—Milton Franklin<sup>2</sup> states that, "so far as I have been able to ascertain, this method has not been systematically used to measure the intensity of the X-rays. This method has been commonly employed to measure the radio-activity of radio-active substances. Air is rendered a conductor of electricity by this ionizing agent, and the measurement of the amount of current flowing through it, under given conditions, gives an absolute index of the activity of the radiation. It is necessary only to charge the electroscopes by applying a rod of vulcanite, sealing-wax, resin, or other suitable material, which has been previously electrified by friction, and then to time the transit of the filament under the influence of X-rays. The rate of discharge will vary directly as the activity of the radiation."

The working of the instrument is as follows:

"The electroscopes is charged by having brought into contact with the knob, a rod of vulcanite which has been electrified by friction. The knob is brought into communication with the filament while the vulcanite is in contact, and released as soon as the filament has assumed a horizontal position. The electroscopes is brought to the same distance from the tube as the plate or patient (in any position), and, while the tube is running, the shutter is opened, and the time, in seconds, occupied by the

<sup>1</sup> Wiener klin. Woch., May 31, 1906.

<sup>2</sup> New York Medical Journal, April 22, 1905.

filament in transit, is noted. The number of seconds is the exact coefficient of energy of the rays, and when compared with any other reading made, under any circumstances whatever, with a similar instrument, the ratio of energy of the two radiations will equal that of the two times.

“In this method, with an electroscopie of the gold-leaf pattern, the relative activities of two radiations may be compared with great accuracy and expedition, and if one of them is the standard unit of activity or bears a known ratio to the standard, the value of the other, in terms of the standard, will be readily deducible. Atmospheric variations must be taken into consideration. The number of seconds which it requires for the filament to traverse the field, is the coefficient of the strength of the rays. All calculations and variations due to the atmospheric absorption must be eliminated at once.”

*The Radio-active Standard of Phillips.*—Phillips<sup>1</sup> utilizes the principle of Franklin's method of ionization, and suggests radium as the standard unit. He describes the *modus operandi* as follows: “The method consists in attaching two similar discharge vessels one to each of the plates of the electroscopie. The needle, a thin strip of silvered mica, is only electrified inductively, and the forces acting upon that end of it which comes to rest above the centre of the gap are able, when the rods are electrified equally, to produce a condition of equilibrium. The horizontal rods are connected with the standard radium; when the rods are equally charged, the needle is steady, but gives no deflection. \* \* \* We may also conveniently compare the activities of various substances, by noting the time taken for a gold-leaf electroscopie to discharge between certain potentials. To do this with anything approaching accuracy, however, the motion of the leaf must be observed with a reading telescope.” He calls the absolute unit the Becquerel, or one Curie, while the commercial unit might be appropriately known as one “ray.”

Dr. Henry G. Piffard<sup>2</sup> takes a brass ball, about one and one-quarter inches in diameter, and supports it about four inches from the wall of the tube just within the circle of rays issuing from the anterior hemisphere. The ball is then connected by a cord about eight feet long to the charging device of the electroscopie. As soon as the current passes through the tube the aluminium needle or foil indicates the charge, and the angle is easily read off on the scale. For this purpose he found Braun's electroscopie (which is graduated in volts) or his own (which is graduated in degrees of an arc) very convenient. The angle varies directly with the current passing through the tube, and also shows whether the tube is running steadily or not, and indicates any notable change in the vacuum.

<sup>1</sup> Archives of the Röntgen Ray, June, 1906, p. 27.

<sup>2</sup> Journal of the American Medical Association, Sept. 15, 1906.

## E. THE PHOTOMETRIC METHODS.

These methods consist in comparing the fluorescence of a platino-barium cyanide screen with an artificial light, either with a fluorescence produced by radium or a radio-active salt.

*The Radiometer of Courtade.*—This instrument consists of a lead shield containing two similar openings, and covered by a fluorescent screen. The radium, which serves as a standard of fluorescence, is placed behind one aperture. The degree of fluorescence on the second screen, produced by the X-rays, is equalized with that of the standard by altering the distance of the Crookes tube. This distance will be a measure of the amount and the quality of the radiation. This method is not thoroughly or absolutely correct, because the intensity of the fluorescence of all the platino-barium cyanides is subject to great variations, when exposed for a long time to the action of radium or the X-rays.

*The Guilleminot-Courtade Method.*—Founded on the same principle as the radiometer of Courtade, Guilleminot employs a sample of radium as his standard of comparison, whose activity is 50,000. He considers the unit of quantity of the X-ray is, that quantity falling on one square centimetre of the surface in one minute of time. This unit he calls the unit "M." For example, if the Crookes tube has to be placed at a distance of 3 metres, in order to produce an equal illumination of the screen, then the intensity of irradiation of the field at 3 metres from the tube is said to be unity. From this it is easy to calculate the number of units "M" absorbed per minute at a distance of 10, 15, or 20 centimetres. Thus, in the above example the number of units absorbed per minute at 10 centimetres distance is 900, "M" = 3 metres (300 cm.); then  $\frac{300 \text{ cm.}}{10 \text{ cm.}} = 30$ , therefore 30 cm. x 30 cm. = 900, while at 15 cm. it is 400, etc.<sup>1</sup> This is open to the many objections mentioned before, the platino-barium-cyanide changing its color of fluorescence, etc. This does not give us the amount of absorption in the tissue, but we infer that from calculations deduced.

*The Fluorometer of Williams.*—This instrument<sup>2</sup> depends upon the distance that a tungstate of calcium screen must be held from a given vacuum tube, in order that the illumination from it may equal that from a radio-active substance which has been measured by a standard source of light. "I found," says Williams, "that when a tungstate of calcium screen with the radium (Curie) lying upon it was placed over a vacuum tube in a dark room, and the X-rays allowed to strike it, the radium was less bright than the luminous screen; but that as the screen was moved farther away from the vacuum tube, the brightness of the screen diminished until a point was reached at which the screen was less bright than the

<sup>1</sup> Archives of the Röntgen Ray, June, 1906.

<sup>2</sup> The Röntgen Rays in Medicine and Surgery, 1903, p. 640.



radium, and that then by gradually approaching the screen nearer the vacuum tube a point was found at which the radium and screen were about equally bright.

“I experimented with several tubes in this way, and found that the distance at which the screen and the radium were about equally bright was different with different tubes, the limit of variation being between 10 and 41 centimetres; and the distance was constant for the same tube under the same conditions. As, by means of a photometer, the amount of light given off by the radium can be measured in terms of a known standard, so the amount of fluorescence produced on a tungstate of calcium screen by a given tube and the brightness of which a given screen is capable may both eventually be referred to the same standard. The fluorometer may serve as a basis, with a given apparatus, for determining the length of exposure when X-rays are used as a therapeutic agent, and likewise when they are employed for taking radiographs.”

This instrument has the objection that the durability of tungstate of calcium varies with different tubes, and also because the vacuum of the tube changes during exposure and requires constant attention.

*The Method of Contremoulins.*—With this method, instead of employing radium, the standard fluorescent screen is illuminated by an acetylene light. This is open to the same objection as stated above.

*Selenium Photometer.*—In 1905 Ruhmer Levy presented, at the Berlin Congress, a new instrument for measuring the X-rays. A selenium cell is clamped in position at a fixed distance from the anode, a current from a couple of dry cells is passed through the selenium, and its intensity is read off on a milliamperemeter. The X-rays alter the resistance of the selenium, and the variation of the current is therefore a measure of the quantity of the rays.

Dunham's instrument<sup>1</sup> consists of a selenium cell, which is placed inside of a wooden pill-box and surrounded by tungstate of calcium. This and a voltmeter are placed, in series, in a direct current of not less than 60 volts. When this is placed before an X-ray tube, the tungstate of calcium is caused to fluoresce and the light derived from the fluorescence causes the resistance of the selenium cell to be reduced. The fluorescence is much less powerful than a 15-candle-power lamp. This lowering of resistance in the cell allows the current to flow more readily, and this can be directly measured by a very sensitive voltmeter. The next instrument depends for its action on the fact that a 2-per cent. solution of iodoform in chloroform is very easily and uniformly affected by the X-rays. Its appearance when so treated varies from a light pink to a very dark reddish brown. The second instrument is as follows: The selenium cell and voltmeter are put in series as before, but no fluorescent salt is used. The wooden box is removed and the cell placed in a light, tight box. The

<sup>1</sup>Lancet-Clinic, Cincinnati, August 25, 1906.

resistance of the selenium cell is reduced by the electric lamp beyond a partition. The light must pass from a lamp to the cell through the bottle because of the small aperture. To make this doubly certain the opening is fitted with a small cylinder so that the rays must pass as desired. When it is desired to measure a given dosage, all that is necessary to do is to fill the bottle, place it in the box, and make the reading. The solution is clear and practically all the light passes to the cell. The resistance drops and the voltage as read on the meter goes up. The bottle is now removed and laid on the surface of the patient near the part to receive the irradiation. After the treatment it is quickly placed in the box and the reading taken. The quantity of X-rays will be read by the difference of the voltage before and after the exposure.

Dr. George C. Johnston<sup>1</sup> takes advantage of the fluorescence produced on the tungstate of calcium or other screen as indicating the quantity of the X-rays emitted. The fluorescing screen is placed in a light, tight box, and facing it is a selenium cell. Such a cell, when kept in total darkness, may have the resistance of several hundred ohms, yet on permitting light to strike the cell resistance falls almost instantly, and this alteration bears a direct relation to the intensity of the light. If there is placed, in series, with such a cell a galvanometer or ammeter of sufficient delicacy, a series of current such as an ordinary dry battery and a variable rheostat providing a means of introducing more or less ohmic resistance into the circuit, and the rheostat, the measuring instrument, and the selenium cell be balanced, the point will be found at which the ohmic resistance of the rheostat, the communicating wires, the selenium cell, and the measuring instrument will exactly balance the electro-motive force of the battery.

If, however, the container, having within it the screen and cell, be placed in the path of the X-rays, the screen will become luminous in proportion to the distance from the source of the rays and the quality of rays striking it. The container will be illuminated; the selenium cell under the influence of this light will change its ohmic resistance in proportion to the light, and the current flow will be measured and indicated on the dial of the galvanometer.

*Fluorescence of the Tube and the Appearance of the Electrodes.*—This method does not afford a reliable means of determining the penetrability of the rays, as the fluorescence depends upon the kind of glass composing the tube. In a dark room this fluorescence will be more clearly discernible. Behind the anode there may often be noticed annular patches of fluorescence, indicating a high vacuum. In studying the appearance of the electrodes, a phenomenon sometimes noticed is, the emission of a fine smoky stream around the edge of the cathode; indicating a high degree of vacuum. A low vacuum in the tube can be recognized by a conical

<sup>1</sup>Journal of the American Medical Association, September 15, 1906.

stream of cathode rays of a blue color. The appearance of a cherry-red heat at the anode indicates that the tube is working properly, and that rays of a high degree of penetrability are being produced. However, this will vary according to the thickness of the platinum anode and the strength of the current. It should not be forgotten that the same tube will fluoresce differently with the different amounts of current, which will produce more or less penetrating rays.

*The Thermometric Method.* — Köhler places a thermometer into a depression in the Crookes tube, whereby he gauges the variation of temperature as indicative of the quality and quantity of the rays.

### III. Natural Fluorescence in the Human Body and its Artificial Production.<sup>1</sup>

Fluorescence may be defined as a property possessed by certain substances of absorbing visible or invisible rays and emitting visible light. Fluorescence and phosphorescence are not, however, synonymous, in that the former is evidenced only when the exciting cause is acting, and that the latter continues after the cessation of the exciting force. Long ago it was asserted and proved that a natural fluorescence existed in the tissues of the human economy. The crystalline lens, the cornea, the aqueous and vitreous humors are all fluorescent. Again, it has been demonstrated repeatedly that the liver, heart, lungs, spleen, kidneys, brain, muscles, nerves, etc., contain a fluorescent material, in many respects resembling quinine, to which the name of "animal quinodin" has been applied. Half a century ago the view was advanced, and still very largely obtains, that an intimate relation exists between the decrease of animal quinodin and malarious affections; therefore the apparent wisdom of exhibiting quinine to augment the fluorescence of the devitalized tissue to its normal point. Based upon these views, experiments were instituted and malarious patients were treated in darkened rooms with purple hangings, in the belief that the sporulation of the plasmodium of malaria could not occur in the absence of light, and especially red light, corresponding to the Finsen treatment of smallpox. Thus, from the deductions of various observers and experimenters, the administration of fluorescent substances has been tried, and the blood thus affected has been the subject of an interesting study both by the X-rays and with radium. The fluorescent substances must of course be harmless, and a radiation employed capable of offering a fluorescence deep within the tissues. Sunlight, electric discharges, the ultra-violet rays, the X-rays, and the

<sup>1</sup> This subject has been most exhaustively and elegantly investigated by Dr. William James Morton, of New York City. For a clear exposition of the study, the reader is referred to Morton's original paper, "Fluorescence Artificially Produced in the Human Organism," *Journal of the American Medical Association*, April 1, 1905, from which parts of the above article have been taken.



Beequerel rays are all capable of exciting fluorescence and phosphorescence within the human body. For a study of the physiological action of light upon animals and plants, the reader is referred to the chapter devoted to "Phototherapy."

#### APPLICATION IN DISEASE.

As a therapeutic agent, Dr. Morton says: "I employ quinine bisulphate in doses of from five to fifteen grains daily, according to the natural physiologic tolerance of the patient; fluorescin, a 1 to 30 aqueous solution, from six to twenty drops, three times daily, one hour after meals; esculin, from five to fifteen grains daily.

"In treatment of an extremely obstinate case of lupus, one patient has now taken ten drops of the fluorescin solution three times daily during the last three months and, employing the X-ray, not only has his lupus healed over large areas, but he also has gained thirty pounds in weight in the three months. Both in hospital and in private practice my cases of lupus heal more rapidly and get permanently cured by this method and in less time than by any other method I have used.

"I have ready to report six patients with tuberculous glands of the neck, two already subjected unavailingly to numerous surgical operations for removal, who are now perfectly well. One case of tuberculosis of the hip-joint is making marked improvement.

"In tuberculosis of the lungs the method is giving good results, not yet ready to be reported on *in extenso*.

"In from one to three days after beginning treatment a reaction occurs. The afternoon temperature in a recent case rose from normal to 103° F. The cough, night sweats, and lassitude increased. Examination of the sputum at this time revealed an enormous increase of the number of tubercle bacilli. This reaction lasted about a week and then the temperature gradually fell to normal, with corresponding improvement in the other symptoms. The patient then entered on a stage of steady gain in weight and comfort and personal appearance. The case is under most rigid observation by skilled consultants and will be reported on later."

Morton asserts that the fluorescence is much increased if radio-active water is used to prepare fluorescent solutions. He administers a half ounce of radio-active water in the morning, and again in the evening, believing that this liquid absorbs and holds the emanations of radium, becoming a secondary source of radiation; the charged water exciting the fluorescence. He successfully combats those scientists who deny the possible existence of a radio-active fluid.

As is usual in such studies, the mass of literature, good, bad, and indifferent, upon the subject in hand is most confusing. I append Dr. Morton's résumé: "The excitation of fluorescence within tissue is a

species of phototherapy and dependable on the same basis for curative effects. The term sensitization is not accurate, for it is not known what the term means. There is no proof that fluorescent substances make the cells or other micro-organisms vulnerable to the exciting radiation.

“What the fluorescent light lacks in intensity is compensated for by propinquity to tissue.

“The method here outlined consists of a medicinal saturation of the entire blood system with a fluorescent solution, and submission of parts or of the whole of the patient to the Röntgen and Becquerel radiations, and to electric discharges.

“The method naturally includes filling cavities with fluorescent solutions, as well as using these solutions medicinally.

“The curative effects obtained by this method are probably due to the fluorescent light. This method permits of an improvement in skiagraphic effects and of fluoroscopic examinations.

“Following the suggestions of the use of fluorescent solutions in diagnosis and treatment, the method has proved of value in determining the position and size of the stomach and other cavities of the body.

“The thoracic cavity presents on the fluoroscope a degree of illumination greater than that produced by the X-radiation alone.

“The method is useful in tuberculosis of the lungs, and in other cases of tuberculous deposits, as well as in cancer.”

*Influence of Photodynamic Substances on the Action of X-Rays.*—Kothe<sup>1</sup> is enthusiastic over the enhanced action of the X-rays after the tissues have been previously injected with a one per cent. or per thousand solution of eosin, an hour before exposure. He describes experiments on animals, and with lupus and warts in the clinic. The injection of eosin enables the course of X-ray treatment to be much shortened, the exposure need not be so long, and the reaction occurs sooner and is more intense than without the eosin. The eosin injections also permit the energetic reaction to be restricted to a circumscribed area, while the uninjected, sound tissue around or above scarcely feels the action of the rays.

Theoretically this method of treatment seems very plausible. Practical tests of its value have fallen far short of the early expectations. This is probably due to the fact that such quantities of fluorescent salts as can be absorbed are so widely distributed and diluted in the fluids of the body that no appreciable effects can be produced. The same dilution, approximately, employed experimentally outside the body fails to give any reaction on photographic plates. The effects produced on the patient by the administration of quinine are probably due to its anti-toxic action, counteracting the toxins resulting from efficient Röntgen treatment and the consequent break-down and absorption of diseased tissues.

<sup>1</sup> Deutsch. med. Woch., Berlin, vol. ix., 1904.

## CHAPTER V

### THERAPEUTIC VALUE IN DISEASE.

#### I. Cutaneous Affections.

##### LUPUS ERYTHEMATOSUS.

IN the first case of lupus erythematosus treated with the X-rays,<sup>1</sup> the method employed was precisely the same as that used in cases of lupus vulgaris. The result was a rapid disappearance of the cellular infiltration in those areas exposed to the direct action of the rays. Immediately surrounding this area a ring of pigmentation forms, which, however, quickly disappears. The skin remains perfectly flat, regular, and practically normal after the rays have been discontinued.

Jutassy<sup>2</sup> reported a case of lupus erythematosus in which he effected an absorption of the infiltrating cellular elements, deposited by the capillaries of the corium and of those of the corpus capillare. A partial recurrence of small extent was observed in those portions which the rays had difficulty in reaching.

Hahn and Grouven<sup>3</sup> report successful results obtained in cases of lupus erythematosus, as do likewise Sjögren,<sup>4</sup> Sartin,<sup>5</sup> and Török and Schein.<sup>6</sup>

##### LUPUS VULGARIS.

That the X-rays are most beneficial in the treatment of lupus vulgaris is to-day the consensus of opinion among dermatologists. Freund and Schiff were the first to give a detailed account of the favorable influence of the X-rays in this disease. The rays seem to have a selective action on the tubercles, and in continued treatments cause a sloughing off of the hardened, gummy masses, which in time are replaced by healthy scar tissue. The deduction of Freund in two cases treated by him as early as 1897 is, "that there is primarily set up an inflammatory reaction within the already discovered diseased tissue by the rays."

After irradiation there results a specific reaction, causing the tubercles to become visible; this is followed by a loosening of the tubercles with an

<sup>1</sup> Fortschritte der Röntgenstrahlen, vol. ii., by Dr. E. Schiff.

<sup>2</sup> Wanderversammlung Ungarischer Aerzte, Aug., 1899.

<sup>3</sup> Aerztl. Verein, Hamburg, 1900.

<sup>4</sup> Fortschr. a. d. Geb. d. Röntgenstrahlen, 1901, v. p. 37.

<sup>5</sup> Lancet, 1901, ii. p. 144.

<sup>6</sup> Wiener med. Wochen., 1902, lii. p. 847.



increase in their size, due to an augmented blood supply, which is succeeded by a shedding of the masses. With the swelling of the tuberculous nodules there is set up a swelling of the already infiltrated lymphatic glands in the vicinity of the tuberculous area.

Birkett<sup>1</sup> treated a boy, aged 15, with a family history of tuberculosis, who had two distinct primary lupus growths in the oro-pharynx, each situated partly on the lateral and partly on the posterior pharyngeal wall. The growths were distinctly nodular in appearance, about the size of a swollen sago grain. Medical and surgical measures were inefficient, and resort was made to the X-rays. A regulating tube with a vacuum equal to a 3-inch (7.5-cm.) spark-gap was employed. Twenty-three daily exposures were given. A recurrence was treated in the same manner, and the results at the present time are most satisfactory.

In cases of lupus the reaction always runs a similar course, the tubercles gradually swelling, turning dark red, and becoming turgescient; at the same time irregular dark spots develop in regions previously unaffected, which subsequently take on the character of lupus nodules. These nodular masses subsequently drop out, leaving behind cavities with a circular punched-out appearance about the size of a pin-head.

The results are on the whole as satisfactory as those obtained by Finsen's method. The latter may give better results, but the procedure is more or less tedious, the apparatus is expensive, and often fails to work satisfactorily. With the X-rays a larger field of affected skin can be treated at one exposure than with the Finsen light.

M. Morris and S. E. Dore<sup>2</sup> state that "the X-rays have a sphere of usefulness, but in cases of lupus they are much inferior as a curative agent to the treatment advanced by Finsen. However, the rays can be applied to cavities which are inaccessible to the Finsen light."

E. Smith<sup>3</sup> reports a case of lupus vulgaris, of fifteen years' standing, successfully treated and apparently cured by X-ray irradiations. The patient was a man of eighty, who had been told that he was suffering with a cancer of the right side of the nose, the inner canthus of the right eye, and the inner thirds of the lids. Twelve treatments were given, marked improvement being noticeable on the second treatment, which was interrupted until the affected area was entirely healed. After the second treatment, healthy granulations appeared and healing promptly followed.

The following case came to me for treatment. The patient was a young man in whom lupus had developed very slowly upon the side of the nose, extending over the bridge to the inner canthus of the opposite eye. There was no pain and little or no exudation. Small nodules

<sup>1</sup> New York Medical Record, December 24, 1904.

<sup>2</sup> British Medical Journal, June 16, 1903.

<sup>3</sup> Buffalo Medical Journal, January, 1901.

distinctly separated from one another were noticeable on palpation. Microscopic examination of the diseased tissue confirmed the diagnosis. After twelve treatments he was permanently cured.

Dr. H. W. Van Allen<sup>1</sup> reported fifteen cases of lupus vulgaris, with 80 per cent. cures. The average time since treatment was discontinued is from one year to eight months. The average time of treatment is six months, the shortest period being three months, and the longest nine months. The most recent case was treated three months ago. The longest time that has elapsed since treatment is three years. Eleven cases were cured; in one there was an apparent cure; one is returning, and two cases were not benefited.

#### NÆVUS.

The removal of hair from hairy nævi was successfully accomplished by Freund<sup>2</sup> (in his first case of hypertrichosis treated by this method) and likewise by Pusey.<sup>3</sup>

*Vascular Nævi.*—Jutassy<sup>4</sup> has given a very interesting report of the successful treatment of an extensive vascular nævus of the face. Over part of the area involved the nævus was flat, but on the cheek and nose there were dilatations forming angiomas from the size of a hemp-seed to that of a bean. The exposures were carried to the point of producing a very acute dermatitis with free vesication; as a result the growth was practically destroyed. There remained over the area a smooth scar of almost normal color. No trace of the angiomas remained. A year and a half later the improvement had been maintained.

Pusey believes that "it is possible that, by setting up an acute reaction in a vascular nævus, there may be produced scar tissue which will be of such a character as practically to destroy the lesions. Of course, the likelihood of so doing is greater the less the dilatation of the blood-vessels. It is surely true that where there are large angiomas the method will not be very effective, though Jutassy's case seems to show that it may be possible to deal with superficial angiomas."

Lassar, of Berlin, states that applications of radium give better results in cases of nævus than do the X-rays. I am using radium and the X-rays alternately, with apparently good results. At present I am treating a young boy who has a nævus covering most of one cheek. For a control test, one-half the growth below the eye is exposed to the rays, the upper part being shielded by lead. No dermatitis has resulted; the exposed area is changing from a deep red to a brownish hue, and offers as a result of lessened vascularity a lighter color on pressure.

<sup>1</sup> Journal of the American Medical Association, September 15, 1906.

<sup>2</sup> Wien. med. Wochens., 1897, xlvii. p. 428.

<sup>3</sup> Röntgen Rays in Therapeutics and Diagnosis, p. 339.

<sup>4</sup> Pest. med. chir. Presse, 1900, xxxvi. p. 73, quoted by Pusey.

## ALOPECIA AREATA.

Ullmann treated a patient by two exposures of fifteen minutes each, on alternate days, the tube being "medium soft," at a distance of 15 cm. The hair in the vicinity fell out; but at the end of three months it began to grow, but was of a darker color. The treatment had evidently stimulated both the growth and pigmentation of the hair, and this result has been permanent.

The treatment of alopecia areata by the X-rays has been reported by Kienböck<sup>1</sup> and Holzkecht.<sup>2</sup> Kienböck reported a case of a young man in whom the affection had existed for three years. After two months of X-ray treatment dark-colored normal hairs appeared, while upon the affected surfaces the growth of hair did not occur.

Holzkecht used the method with some success in several cases. In one case of alopecia areata that had progressed steadily for five months, after six months' treatment with the rays there appeared a fine growth of hair.

*Parasitic Alopecia.*—In alopecia areata of mycotic origin it is possible that the X-rays may prove of use, and in cases of tinea tonsurans simulating alopecia areata this treatment would probably be successful. That X-rays, however, cause temporary atrophy of the follicles is not a valid reason for believing that they would be contraindicated in alopecia areata, for unless a reaction is produced several times, the healthy hair-follicles regenerate.

In treating certain cases of epilepsy, I observed in one bald-headed patient that the application of the rays was followed by a growth of short, stiff hairs.

## HYPERTRICHOSIS.

Freund was the first operator in the field who employed the X-rays in dermatology with success. He artificially produced an alopecia in a case of hirsuties. The patient had previously undergone the usual course of treatment when Freund experimented on the case with the rays. In the beginning, the field was exposed two hours each day, and within twelve days the hair commenced to fall out in large, thick tufts, and a few days later the part was completely bald. This was the first case of this kind cured by the X-rays. It is recommended that any type of hirsuties should be given more numerous but less intense exposures.

Jutassy<sup>3</sup> states that he has employed the treatments as outlined by Freund and Schiff with similar results. In the process of epilation there are four stages prominently defined. 1. In the *stage of exposure* nothing of any importance is discernible. 2. During the *hyperæmic stage* there

<sup>1</sup>Wien. klin. Wochens., 1900, xiii. p. 1053.

<sup>2</sup>Ibid., 1900, xiii. p. 1177.

<sup>3</sup>Orvosi Hetilap, 1898.



may be a scattered or even a complete shedding of the hair, but this is only temporary, as the hair roots are not destroyed. 3. In the *inflammatory stage* there is an acute inflammatory process, with an accompanying slight, transient hyperæmia. Not infrequently this process advances to a pustular stage, and falling of the hair is in many cases complete and permanent. 4. *Regeneration of the hair* occurs after a period of from two to three months and in those insufficiently treated. The absence of any signs of recurrence after a period of about three months indicates that the treatment has been satisfactory, and a prognosis of a permanent alopecia may be rendered. In one case there was produced a permanent alopecia in less than three weeks; seven treatments were given with a 20-minute exposure at each sitting.

Barthélemy and Oudin<sup>1</sup> remark that their conclusions are directly opposed to those arrived at by Schiff, Freund, and a number of noted American and English observers.

Two series of experiments were conducted on women, the hairy field of the pubic region being the part selected. The hair of each of the patients presented dissimilarities in color and thickness. In the first series the exposure was of short duration, while in the second series the exposure was of long duration. In the first two cases, with exposures of ten minutes each, and repeated daily or every other day for a period of from two to four weeks, no satisfactory results were obtained. The third case, frequently exposed for a long time, was followed by an erythema and a profuse shedding of hair. The exposure of the cases of the second series extended from ten to thirty minutes. The results were negative in three of the cases, while in the other three cases there was only a slight loss of hair, which came out very readily upon combing or by pulling upon it. In only two of the cases treated as above was there a complete falling of the hair, one of these cases being accompanied by a wide-spread erythema.

Schiff and Freund<sup>2</sup> reported that in three cases a slight erythema was the sole visible result of the exposures. Prior to the falling out of the hair, the skin was visibly undergoing the process of bronzing. The pigment continued to accumulate until the hair fell out, followed by its rapid disappearance. Previous to shedding, the hair turned snow-white, lost all its pigment, and microscopically exhibited vacuoles. In a single case this phenomenon had been repeated three times, when the recurring dry hairs were again submitted to the action of the rays.

Sjögren<sup>3</sup> observed a rapidly disappearing pigmentation in a brunette of 25 years who was subjected to treatments similar to those outlined by Schiff and Freund.

<sup>1</sup> La Radiographie, 1900, xxxix.

<sup>2</sup> Wiener med. Wochenschrift, 1898, xlvi. p. 1058.

<sup>3</sup> Bibliotheca medica, Heft 8.

After the treatment all the cutaneous roughness and unevenness disappear, and likewise the scarring resulting from a previous folliculitis. The integument becomes smooth and free from all blemishes. Occasionally there may be noted a few flat, colorless depressions, very similar to those following a treatment by electrolysis. The shedding of the hair after a long series of exposures would indicate accumulative action of the X-rays. Forster<sup>1</sup> also expresses a similar belief.

Grunmack has conducted experiments to ascertain the epilatory effects of the rays, but with varying results, due to lack of necessary precautions.

I have treated several female patients who were disfigured with growths of superfluous hair. One woman presented a growth of hair on the neck and forearm. I treated the forearm first, to determine the dosage and the patient's susceptibility, and after ten treatments of 5 minutes each, covering a period of ten months, the hairs were removed, without even a vestige of erythema. In one patient the growth of hair returned, but subsequent treatment permanently eradicated the growth. This X-ray treatment obviates the pain of electrolysis.

#### FAVUS AND TINEA TONSURANS.

The use of the X-rays in the treatment of tinea tonsurans and favus was suggested by Freund.<sup>2</sup> Cases of tinea tonsurans successfully treated by the X-rays have been reported by Schiff and Freund,<sup>3</sup> Török and Schien,<sup>4</sup> and others. Cases of favus successfully treated have been reported by Schiff and Freund,<sup>5</sup> Hahn and Albers-Schönberg,<sup>6</sup> Török and Schien, Kienböck, and others. One case of Schiff and Freund has remained cured for a year. In these cases the reaction needs to be carried to the point of causing complete alopecia and slight cutaneous inflammatory reaction. Theoretically the treatment is ideal. It causes a falling out of the diseased hairs, at the same time destroying the organisms upon which the disease is dependent. The alopecia which it causes is temporary unless accompanied by a greater reaction in the skin than is necessary.

The objections to the method lie in the fact that the process is a tedious one, and that the exposure of a large part of the scalp in tinea tonsurans or favus is a procedure of some risk unless carried out with caution. All that is said of the treatment of tinea tonsurans applies equally well to the treatment of favus.

<sup>1</sup> Wiener klin. Wochenschrift, 1897, No. 3.

<sup>2</sup> Wien. med. Wochens., 1897, xlvii. p. 856.

<sup>3</sup> Fortschr. a. d. Geb. d. Röntgenstrahlen, 1899, iii. p. 109.

<sup>4</sup> Arch. f. Derm. u. Syph., 1901, lvi. p. 132.

<sup>5</sup> Wien. med. Wochens., 1902, lii. p. 847.

<sup>6</sup> Münch. med. Wochens., 1900, xlvii. pp. 234, 324, 363.

Batten<sup>1</sup> proved that with X-rays we can make the hairs fall from the bottom of their follicles, thus overcoming the difficulty of treating this disease. His method of treatment is as follows: A boy's ordinary close-fitting cap is covered on the outside with a continuous, fairly thick layer of white lead, and the latter with linen or muslin; holes are then cut in this white-lead screen to correspond with all the ringworm patches to be treated; through these holes the scalp is exposed to X-rays from a medium or moderately hard tube for ten or eleven minutes, six times within a fortnight. The scalp should be six to eight inches from the anticathode, and the ears, neck, and face protected from the rays by the white-lead cap or similar shield, or by a diaphragm over the tube. Next a simple, penetrating parasiticide lotion should be applied morning and night over the whole scalp, during the period of the treatment. When the patches are quite bald, a mild parasiticide ointment should be rubbed into the scalp once a day, applying the lotion also to the entire scalp. The hair usually begins to grow within seven or eight weeks from the commencement of treatment, and by the end of the third or fourth month it is fully grown.

Adamson<sup>2</sup> states that, when the X-rays are used for the treatment of ringworm of the scalp, the hair of the part exposed to the rays may be made to fall, leaving a smooth, bald area, entirely free from stumps, and when this grows again, after an interval of some weeks, the new hairs are found to be free from ringworm. The fungus has not been killed, but has come away with the old hairs, and by the time the new hair grows not a trace of it is left. Those using this method have, however, always been chary of its application, fearing burns or baldness. But now, by means of Sabouraud's radiometer, such accidents can be readily avoided.

The hair begins to fall about fourteen days after the application, and continues to do so for a few days longer. It begins to grow again in from six to eight weeks, and is fully grown at the end of three months, provided that the length of exposure is not allowed to exceed the limit set by the right use of the pastille, that no area or part of any surface is exposed more than once, and that the part exposed is kept at the proper fixed distance from the anticathode of the tube. By this method there is no danger of permanent baldness or injury to the tissues.

Concerning the value of the X-rays in the treatment of tinea, Sabouraud<sup>3</sup> says that ambulant treatment is to be recommended, and instead of the two years formerly required, the cure is complete in three months. The tube should be fifteen centimetres from the diseased area, and at the same time a scrap of platino-cyanide paper should be exposed to the centre of the tube (equal to five Holzkecht's units), but at a shorter

<sup>1</sup> Archives of the Röntgen Ray, August, 1905.

<sup>2</sup> Lancet, June 24, 1905.

<sup>3</sup> La Presse Médicale, Paris, No. 98, Dec. 7, 1904.



distance (eight centimetres). When the thin sensitized paper has changed to the tint "B" of the radiometer, the exposure is terminated. By observing that the shade of the sensitized paper is below the tint "B" on five Holznecht's units, the operator can be confident that there is no danger of an erythema, burn, or permanent baldness. After the exposure the part is treated with an ointment containing the oil of cade, which is washed off each morning. The entire scalp is then rubbed with a ten per cent. alcoholic solution of tincture of iodine, to prevent reinfection from the hairs as they drop out of the exposed patch. Each patch requires a separate exposure.

#### ECZEMA.

Dr. R. Hahn claims priority in radiotherapy of eczema, especially the chronic type. At a meeting of the Medical Society of Hamburg, July, 1898, he reported two such cases that he successfully treated. Both patients suffered from eczema of the thighs for periods of two and four years respectively. In the first case a cure was effected after twelve applications of the rays. In the second case, after four exposures, the hyperæmic condition of the affected part appeared, followed by a slight dermatitis, which, however, disappeared in three days.

Dr. Margaret Sharpe<sup>1</sup> reported a case that affected a small area of the hand, following a burn, which occurred three years previously. The part had been exposed eleven times, each irradiation consuming fifteen or twenty minutes. The lesion faded away gradually, the part appearing more and more pallid as the result of each exposure. There was absolutely no soreness or any inflammatory reaction.

Drs. Montgomery and Ormsby<sup>2</sup> state that several cases of chronic eczema treated by the rays had given most excellent results. In one case of eczema which was exceedingly stubborn and of many years' standing, located in the skin of the scrotum, in which a vitiliginous condition had appeared on the infiltrated skin, ten daily treatments gave the patient relief from the itching; the infiltration gradually disappeared, and later the normal pigment returned.

Hahn<sup>3</sup> believes that if eczema is a germ disease, then, as demonstrated by Rieder, we may expect the X-rays to influence the bacteria directly. If, on the contrary, it is a nutritional disease, the action of the rays in setting up a dermatitis leads us to hope that the reactions of the tissues will cause alterations in the circulation and nutrition with consequent healing. The point of most interest is the rapidity with which the lesions improved (usually after ten to twelve exposures). The effects immediately observed were a decrease and in some cases an absolute

<sup>1</sup> Archives of the Röntgen Ray, February, 1900, p. 5260.

<sup>2</sup> Journal Amer. Med. Assoc., Jan. 3, 1903.

<sup>3</sup> Fortschritte a. d. Geb. d. Röntgenstr., 1901, 1902, v. pp. 39-41.

cessation of the secretion. In all Hahn had fourteen cases, in nine of which he was able to effect absolute cures. Of the remaining cases three failed to materialize after three, four, and eight exposures respectively; of the other two cases, one died of pneumonia, and the remaining one was treated eighteen times with apparently no improvement.

In cases of eczema I usually give short and frequently repeated exposures—*i. e.*, every other day—for the first two or three weeks. After this period I expose the parts every third or fourth day. By this procedure I have in some cases attained very good results. For a further discussion of cases of eczema successfully treated by the rays, the reader is referred to articles by Albers-Schönberg,<sup>1</sup> Meek,<sup>2</sup> Scholtz,<sup>3</sup> Sjögren and Sederholm.<sup>4</sup>

#### ACNE.

Dr. R. R. Campbell<sup>5</sup> reports fifteen cases more or less completely cured by the X-rays. He used a medium soft tube, moderate illumination, about fifteen centimetres from the patient, with exposures of ten minutes each, usually every other day.

“Miss E. R., age 20, had been under constitutional and local treatment for three months, without any appreciable improvement in the local condition. Early in January, 1902, X-ray exposures were begun. She was given three exposures weekly of ten minutes each, with the tube fifteen or twenty centimetres distant. After two weeks there was manifest improvement, and the exposures were reduced to two sittings weekly; by the end of February no active lesions or comedones could be detected, and the exposures were further reduced to once weekly until the end of March, when all treatment was discontinued. No relapse has taken place. No dermatitis or erythema was produced in this case at any time.”

Altogether I have treated ten cases of acne. In one patient, a girl of nineteen, whose face was covered by the eruption of eighteen months' duration, I succeeded in completely curing the patient in thirty-two treatments. These applications were made three times weekly for two weeks and thence once weekly. The tube was fifteen inches from the face, three inches spark-gap, duration of each treatment, two minutes. The applications were just stimulating enough not to produce an erythema. I do not believe in the production of an erythema in the facial region. Seven of the other cases are apparently permanently cured, and recurrences occurred in the other two, after a period of two years. In one case an atrophic condition of the pitted area resulted.

<sup>1</sup> Münch. med. Wochens., 1900, xlvii. pp. 284, 324, 363.

<sup>2</sup> Boston Medical and Surgical Journal, 1902, cxlvii. p. 152

<sup>3</sup> Arch. f. Derm. u. Syph., 1902, lix. p. 421.

<sup>4</sup> Fortschritt. a. d. Geb. d. Röntgenstr., 1901, iv. p. 145.

<sup>5</sup> Journal of the American Medical Association, August 9, 1902, p. 343.

*Acne Vulgaris.*—This chronic inflammatory disease, which involves the sebaceous glands, usually appears in the form of papules, tubercles, or pustules, simple or combined, and chiefly affecting the head, face, and neck, and occasionally the chest.

Dr. Joseph Zeisler<sup>1</sup> reports thirty-four cases of acne of different varieties and of different degrees of severity. Five of these were instances of acne rosacea and four were indurated cases with pustules of the back and chest.

“The bulk of them were, of course, of the ordinary type of acne of the face, many of them of the very severest and most rebellious nature. The exposures were rather mild in character, the distance of the tube, according to its light, being from twenty to forty centimetres.

“I usually start in these cases with three treatments a week for from two or three weeks. After this exposures are given twice weekly only for a time, and later about once a week. A beneficial action can usually be noticed during the second week, when few new pustules are noted and the comedones seem to shrink and dry up. The accompanying seborrhœa oleosa of the face is very promptly influenced. Some of the severest cases which I have ever treated were cured in from four to six weeks, and have so far remained well.”

A minimum reaction to the rays is not always accompanied by the cure of acne, but a moderate degree of dermatitis should be aimed at. The disadvantages of the treatment are the pigmentation liable to follow in brunettes, occasionally the slight cutaneous atrophy, and the exceptionally severe dermatitic reaction. The X-rays cause the hairs to drop out, and evidently check the secretion of sebum. The parenchyma of the sebaceous glands becomes more indurated, and this explains the lasting benefit derived in nearly every case from X-ray treatment.

Dr. Gautier,<sup>2</sup> of Paris, reported sixteen cases of acne vulgaris and acne rosacea which had been successfully treated by X-rays.

In hospital and private practice I have had numerous cases of this disease. In general the results of radio-therapy were successful when combined with other remedial measures. I have noted that frequent five-minute exposures are more satisfactory than longer and less frequent applications. The tube should be of “medium vacuum,” so that the most beneficial results may be obtained.

*Acne Rosacea.*—Jutassy was the first to treat acne rosacea by the X-rays. Hahn<sup>3</sup> reports two cases of acne rosacea in which he obtained satisfactory results. The redness of the nose and of the adjacent parts disappeared, and had not returned after an interval of several months.

<sup>1</sup> Journal of the American Med. Asso., February 21, 1903.

<sup>2</sup> Compt.-rend. du xii. Congrès international de Méd., Moscow, vol. iv., August, 1897, pp. 385-386.

<sup>3</sup> Aerztl. Verein, Hamburg, 1900.



Hyde and Montgomery and Ormsby<sup>1</sup> state the following: "In a few cases of acne rosacea our use of the X-rays has been followed by a very marked improvement. In two very extensive and very severe cases of acne, which had resisted for months all our efforts at treatment, the eruptive symptoms disappeared completely under the use of the X-rays. In other cases a few exposures have seemed to materially aid the other treatment employed.

"The cases of acne in which radio-therapy is of unquestionable value are those in which the disease is limited to a small area. Here the treatment may be pushed, if necessary, to the point of producing atrophy of the affected glands and follicles. When many scattered glands are involved and new lesions are constantly forming, radio-therapy gives temporary benefit, but could not be expected to prevent recurrence of the lesions unless the treatment be carried far enough to produce general atrophy of the sebaceous glands of the face. But the sebaceous glands have a function to perform, and to produce a general atrophy of these glands of the face must be a questionable procedure until we can determine what effect such a course would have on the skin ten, twenty, or forty years later." (Figs. 222, 223.)

#### SYCOSIS.

J. F. Rinehart<sup>2</sup> speaks of the advantages of the treatment of these cases by the X-ray. The treatment is thorough, painless, and there is but little scar tissue left after healing. He reports a number of illustrative cases, and urges that too much haste to obtain reaction is often productive of marked inflammation.

The treatment of sycosis by X-rays was suggested and first carried out by Schiff and Freund,<sup>3</sup> and there are numerous reports in the literature testifying to its success. Successful cases have been reported by Hahn,<sup>4</sup> Spiegler,<sup>5</sup> Rinehart,<sup>6</sup> Scholtz,<sup>7</sup> Gassman and Schenkel,<sup>8</sup> Török and Schein,<sup>9</sup> and others. The treatment has proved equally efficacious in parasitic and non-parasitic sycosis. In some of the cases the patients have remained well a year after the cessation of treatment. A typical successful case of parasitic sycosis is that reported by Zechmeister.<sup>10</sup> In

<sup>1</sup> The Journal of the American Medical Association, January 3, 1903.

<sup>2</sup> Philadelphia Med. Jour., 1902, ix. p. 221.

<sup>3</sup> Wien. med. Wochens., 1897, xlvii. p. 856; Fortschr. a. d. Geb. der Röntgenstrahlen, 1899, iii. p. 109.

<sup>4</sup> Deut. med. Wochens., 1901, xxvii. V. B., p. 29.

<sup>5</sup> Arch. f. Derm. u. Syph., 1901, lvi. p. 131.

<sup>6</sup> Philada. Med. Journal, 1902, ix. p. 221.

<sup>7</sup> Arch. f. Derm. u. Syph., 1902, lix. p. 421.

<sup>8</sup> Fortschr. a. d. Geb. d. Röntgenstrahlen, 1899, ii. p. 121.

<sup>9</sup> Wien. med. Wochens., 1902, lii. p. 847.

<sup>10</sup> Monatsheft f. prakt. Derm., 1901, xxxii. p. 329.

this case the face was covered with deep follicular pustules. Hyphomycetes had been demonstrated around the roots of the hair. After five strong exposures there was a slight reddening and scaling of the pustules. Ten days later the pustules had vanished, and in two weeks more the disease had entirely disappeared. Three months later there was no recurrence.

Dr. J. Zeigler<sup>1</sup> reports very good results with the X-rays in four cases of sycosis; after two or three radiations, pustules ceased to form, where epilation had taken place new hairs began to show after two months, and no relapse has since appeared.

Schiff and Freund<sup>2</sup> speak of X-ray treatment of sycosis as follows: "When the rays were applied seven times, complete recovery was obtained, leaving the skin smooth and free from all inflammatory contractions. The action of the rays seems to be anti-parasitic, as no recurrence had appeared after the second month."

#### PRURITUS ANI AND PRURITUS VULVÆ.

Dr. J. Rawson Pennington<sup>3</sup> has treated several cases of pruritus ani with the X-rays. In one case, after the third treatment he began to notice a change for the better. The exposures were continued, and the tough, leathery condition soon began to disappear. As it passed away the itching subsided. There has been no itching for the last four months, and the skin is normal to the touch.

In another case the patient had previously undergone treatment for hemorrhoids. Pruritus followed the operation and had been very obstinate since. A few exposures to the X-rays eliminated the trouble.

He also reported a series of thirteen cases of pruritus ani wherein most of the cases were cured by the rays and, though still under treatment, all improved. The skin is left smooth, soft, clean, and pliable. While there is no objection to the use of other procedures in conjunction with the X-rays, none was employed in these cases, proving that the successful results were entirely due to radio-therapy.

Scholtz<sup>4</sup> has seen improvement in a case of pruritus vulvæ, and Sjögren and Sederholm<sup>5</sup> have reported seven cases of pruritus vulvæ which were decidedly relieved by this means.

#### XERODERMA PIGMENTOSUM.

At the Edinburgh Medico-Chirurgical Society, Dr. Allan Jameson<sup>6</sup> exhibited a little girl suffering from xeroderma pigmentosum which had

<sup>1</sup> Journal of the American Med. Asso., February 21, 1903, p. 513.

<sup>2</sup> La Presse Médicale, May 27, 1899.

<sup>3</sup> New York Medical Journal and Philadelphia Medical Journal, February 20, 1904.

<sup>4</sup> Arch. f. Derm. u. Syph., 1902, lix. p. 421.

<sup>5</sup> Fortsch. a. d. Geb. d. Röntgenstr., 1901, iv. p. 135.

<sup>6</sup> Journal of the American Medical Association, February 14, 1903; Lancet, London, 1903, i. p. 105.

been treated by the X-rays. At the age of twelve months she began to develop freckles at the side of the nose. Later telangiectases and whitish spots appeared on her face. The disease had extended to the hands and wrists. When first seen, there was an epitheliomatous growth the size of a sixpence on the tip of the nose and numerous warty excrescences on the face. Thirty-four exposures to the rays, of five minutes each for the face and thirteen minutes for the right hand, were given. The growth on the nose and the warty growth both disappeared. The nose is now whiter than the rest of the face, and there is a marked improvement in the right as compared with the left hand.

#### PSORIASIS.

Attempts to employ radio-therapy in the treatment of psoriasis have thus far given positive results in the hands of Ziemssen and Albers-Schönberg. Jutassy has also made experiments in this direction, but his results are as yet incomplete. Grouven and Hahn<sup>1</sup> have reported most favorable results.

Hyde and Montgomery and Ormsby<sup>2</sup> report their experiments with this disease as follows: "We have treated thirty-two cases of psoriasis with radio-therapy, causing in each case a temporary disappearance of the lesions. From four to ten treatments on a given group of lesions were usually sufficient to cause them to disappear entirely, except for a certain amount of pigment. In lesions in which the thickening was but moderate, the scales often disappeared after the second or third treatment. Relief from itching, when such is present, occurs about the same time.

"In the treatment of psoriasis we use a fairly soft tube and very short exposures, at a distance of ten or twelve inches. It has not been necessary in any case to produce any visible evidences of reaction, not even in erythema or pigmentation. The influence of the rays on psoriasis is in keeping with the fact demonstrated by one of us (Hyde) twelve years ago, and frequently since, that some psoriatic patients can free their skin of all lesions by prolonged baths."

F. S. Burns<sup>3</sup> states that the treatment of this disease by means of the Röntgen rays has been thoroughly tested, and no lesion has failed to disappear under this form of treatment, even though the cases have resisted all other forms of treatment for a considerable period of time. He bases his conclusions on a series of 150 cases.

Morris and Dore<sup>4</sup> state that they have seen good results in chronic patches of psoriasis. From four to ten treatments were usually sufficient, in a given group of lesions, to cause them to disappear entirely.

<sup>1</sup> Niederrheinische Gesellschaft für Natur- und Heilkunde in Bonn, 11, ii., 1901.

<sup>2</sup> Journal of the American Medical Association, January 3, 1903, p. 4.

<sup>3</sup> Boston Medical Journal, October 23, 1903.

<sup>4</sup> British Med. Journal, June 6, 1903.





FIG. 222.—Profile and full view of a patient at the Philadelphia Hospital with acne rosacea.



FIG. 223.—The same after fifty irradiations, which I employed thrice weekly. Distance of tube (soft), 15 inches (38 cm.). Secondary current 2 ma., equivalent to No. 2 scale of Benoist.



FIG. 224.—Epithelioma of the nose, before irradiation.



FIG. 225.—The same after I irradiated the growth at the Philadelphia Hospital.



FIG. 226.—Epithelioma of 15 years' standing, in which radium therapy was employed as a control test, by shielding half the growth with lead. The protected half was subsequently treated with the X-rays. The X-ray treatment brought about a marked improvement. Treatment with radium was negative.





FIG. 227.—Epithelioma of the dorsum of the hand, before irradiation.



FIG. 228.—The same after irradiation.

Dr. E. S. Ferris<sup>1</sup> relates the following case : Patient, age 50, has had psoriasis as long as he can remember. At intervals he has undergone both local and constitutional treatment, the only result of which was an apparent lessening of the scales for a short time. Occasionally, even while under treatment, there was diminished activity manifested by disappearance of scales and a pallor of the red patches, but the papules never disappeared. On October 1, 1902, he presented himself for treatment. "I found the disease involved the skin covering almost the entire body. After trying various treatments and brush discharges, I gave him sixteen X-ray applications to his back only, consisting of three exposures of ten minutes each. On the day following the sixteenth sitting, I found the skin tender and of a dusky hue ; later a more marked reaction was manifested. After ten days all traces of the disease except slight redness had disappeared from the part treated. Even this redness was gone in another week, and the lesion on the chest vanished at the same time. This success encouraged me to apply the X-rays to the other parts involved, with the same happy results. At present there is absolutely no trace of the former trouble ; the skin is smooth and soft and of normal color."

Drs. Sjögren and Sederholm, of Stockholm,<sup>2</sup> state that two cases of psoriasis treated with the X-rays were not in the least benefited thereby.

#### SENILE LEG ULCERS.

In 1904, in the service of Dr. Ernest Laplace at the Philadelphia Hospital, I exposed twenty senile leg ulcers to the action of the rays. The patients' ages varied from 50 to 65. Before treatment the ulcers had an angry appearance and an offensive odor, with no granulations. They were treated through sterile unmedicated bandages.

In most of the cases, after several months' treatment, a slight dermatitis resulted, and the applications were discontinued. The secretion was checked, the odor disappeared, and granulations began to sprout. The areas, which previously had been measured and photographed, showed a decrease in size. Three of the patients are still at the hospital and are almost cured. Of the other seventeen some have since died and others have disappeared from observation.

#### VARICOSE VEINS.

McGuire<sup>3</sup> reports two cases of varicose veins. The first patient was a woman, aged 45, with eczema of both legs, complicated with varicose

<sup>1</sup> American Electro-Therapeutic and X-Ray Era, May, 1903.

<sup>2</sup> Fortschritte auf dem Gebiete der Röntgenstrahlen, June, 1901.

<sup>3</sup> Medical Record, September 1, 1906.

veins and an ulceration on the right leg. The ulcer resisted all treatment until the application of the X-rays. This caused inflammation of the skin, which extended over the whole surface of the leg. The treatment was stopped for four days, when it was again tried. Inflammation resulted, but during the next five days, without the application of the X-rays, the dermatitis gradually subsided and by the end of the week had disappeared. The ulcer completely healed and the varicose veins disappeared. The second patient was a man, 50 years of age, with a large bunch of varicose veins on the right leg. Treatment by the X-rays is gradually reducing the tumor and without causing any great reaction of the tissues. The rays cause contraction and atrophy of the tissues and those of low vitality easily break down.

#### HYPERIDROSIS.

Dr. J. T. Dunn<sup>1</sup> has treated a number of cases of hyperidrosis, and asserts that it is necessary to produce reaction, by short repeated treatments, until complete destruction of the sweat follicles has occurred.

In treating cases of hyperidrosis involving the palmar surface of the hands, it is necessary to be exceedingly cautious, as the reaction is usually easily produced and pain is very severe in such cases. It is his experience that reaction appears after six or eight treatments of ten minutes each when applied to the palms of the hands; and on account of the density of tissue involved, pain is severe if the reaction is excessive.

#### KRAUROSIS VULVÆ.

Dr. G. H. Stover<sup>2</sup> reports the case of a woman, aged 50, who had suffered severely from kraurosis vulvæ for several years. She was told that we knew nothing whatever of the effect of the X-ray in this condition, and with that understanding an exposure was made, a tube of medium vacuum being employed. The exposure was made at 2 P. M. in March, 1903; that evening her suffering was so great that her family physician was called. Some hours after the raying he found the diseased area redder than common, swollen and œdematous, the appearance being much like that of erysipelas. Further radiation was decided against, and after a week or two, when the inflammation had subsided, the affected tissue was excised. Possibly the rubbing and cleansing which the patient had given the parts may have had an unfavorable influence.

<sup>1</sup> American Electro-Therapeutic and X-Ray Era, December, 1903, p. 450.

<sup>2</sup> New York Medical Journal, February, 1904.



## LEPROSY.

H. B. Wilkinson,<sup>1</sup> who has had the good fortune to study extensively the subject of leprosy, reported upon a series of thirteen cases to the Manila Medical Society, October 12, 1905.

He began the treatment of leprosy with the X-rays during January, 1904, with a ten-inch spark machine, with which he used a bifocal tube. That portion of the patient which presented the greatest amount of infiltration was exposed to the direct rays of the tube at a distance of about ten inches. The exposure lasted about ten minutes and was repeated at intervals of several days. His object was to approach as near as possible to the burning point without actually producing a burn. He called particular attention, however, to the fact that a cure resulted in the two cases which were accidentally burned. After two or three successive treatments, a blushing of the skin is often observed, which is later followed by scar formation. A tabulated statement of the thirteen cases treated showed that three were cured, seven improved, and three not improved.

He is inclined to believe that, when a local lesion of leprosy is treated with X-rays, the organisms there localized are killed and their bodies absorbed by the system, thereby producing an immunity against the living organisms. This, as may be seen, would be practically analogous with the immunization of individuals against bubonic plague by injecting into them killed cultures of plague organisms. In his cases he simply grew the culture of lepra bacilli in the human body as a culture medium and then killed them by the use of the X-rays. In support of this theory, he cites the following facts: 1. The treatment of one leprous spot on a patient produces improvement in spots at a distance from the one actually treated. 2. The cure in the distant spots seems to progress parallel to—and to be just as complete as in—the one treated. 3. The best results seem to be obtained only when treatment is pushed to the point of killing or beginning to kill the tissues, which would also probably be to the point of killing the organisms. 4. Cases in which there are massive localized leprous deposits are most rapidly improved. There is an abundance of culture on which to operate and thereby produce immunity more rapidly. 5. In diffuse general involvement of slight degree or atrophic character, where there are only a few scattered organisms, little success is to be expected.

Sequeira<sup>2</sup> reports a nodulated form of leprosy of the skin which has shown marked improvement; the hard masses became soft and flat.

Seholtz<sup>3</sup> treated two cases of leprosy with X-rays without results; de la Camp also obtained negative results.

<sup>1</sup>“Some Observations on Leprosy in the Philippine Islands, with an Account of its Treatment with the X-ray,” *Medical Record*, December 9, 1905, reported by a special correspondent at Manila.

<sup>2</sup>*British Medical Journal*, September 28, 1901, p. 851.

<sup>3</sup>*Arch. f. Dermat. u. Syphilis*, vol. lix., 1902, pp. 443-444.

## II. Malignant Growths.

### A. EPITHELIOMA.

In the X-ray treatment of epitheliomata a number of circumstances must be considered,—the rapidity of the growth, its character, location, and glandular involvement, age of the patient, and the state of health.

When the epithelioma has grown rapidly, I advise an immediate operation and subsequent X-ray treatment. In cases of slow growth I am in favor of X-ray treatment only. (Figs. 224, 225, and 226.) The severity of an epitheliomatous growth is largely dependent on the proximity of the lymphatic chain of glands. Thus, such an ulcer of the upper lip is far less likely to produce metastases than one of the lower lip, and consequently irradiation of the former will yield the better results. Likewise the anterior portion of the tongue affords better results in treatment than the posterior part. Again it is easier to irradiate the external than the internal canthus of the eye, because of the excess of lachrymation produced when the latter is treated. In making a prognosis it is essential to differentiate between the forms of epithelioma very carefully, since these neoplasms vary in their malignancy according to their locality and the depth of the tissues involved.

The results obtained in the treatment of epitheliomata by the Röntgen rays have more than satisfied its most sanguine advocates. That these malignant cutaneous growths can be made to disappear entirely has been the common experience of Röntgen therapeutists.

Carl Beck, of New York,<sup>1</sup> and others make a statement which is slightly at variance with the views of certain noted investigators in this line. They deem it essential to remove surgically all such diseased areas. This they regard as the most valuable form of treatment; notwithstanding this fact, they assert that it is proper to employ the rays after the growth has been excised. It is my belief, and which I have abundantly confirmed, that the X-rays should be applied without any surgical intervention.

W. Merrill and W. Johnson<sup>2</sup> were the first in this country to report the results obtained in malignant diseases by treatment with the X-rays. Their first case, one of cutaneous cancer of small dimensions, was cured in October, 1899. The discharge soon ceased, pain was relieved, and in general the result was satisfactory.

Another case reported was an epithelioma affecting principally the nose and involving the nasal septum. The case was carefully watched, and one year later no apparent sign of recurrence was demonstrable.

In the third patient the cutaneous cancer affected the lower part of the bridge and tip of the nose. The treatment was the same as was

<sup>1</sup> Medical Record, February 7, 1902.

<sup>2</sup> Philadelphia Medical Journal, December 8, 1900, vi. p. 1089.

applied in the other two cases, except that the exposures were shorter in duration and more frequent. After an interval of three years the patient has no sign of a recurrence.

They also reported sixteen additional cases<sup>1</sup> regardless of their length of existence, extent of tissue involved, and previous treatment received; ten patients, or 62.5 per cent., are apparently cured; four other cases, or 25 per cent., show improvement, and three of these give promise of ultimate recovery under further treatment.

Sjögren<sup>2</sup> states that in nearly all his cases of epitheliomata treated by means of the rays, a change for the better might be observed even though apparently no inflammatory reaction developed. He seems to be convinced that in order to bring about an absolute cure one must set up an inflammatory reaction of intense severity. This causes a degeneration of all (or at least the majority) of the embryonic cellular elements, which is the aim.

Wm. Sweet, of this city,<sup>3</sup> reports most satisfactory results obtained from his treatments in three cases of epitheliomata involving the tissues surrounding the eyeball.

William Allen Pusey<sup>4</sup> reports having treated several cases of epithelioma, in which there was no involvement of the deeper orbital tissues, and all resulted in cures where sufficient treatment was permitted. No relapses have occurred, and some of the cases were treated about three years ago.

Wm. M. Sweet<sup>5</sup> believes that it is no longer right to resort to plastic operations in cases of epithelioma in ocular affections, basing his judgment on the successful results of eighteen out of twenty cases treated.

Allen<sup>6</sup> treated five cases of Jacob's or rodent ulcer, which were entirely cured by the application of the X-rays. Two of these involved the lower eyelids, two the nose, and one the centre of the cheek. All these were of long standing and very slow development: one of them, at the side of the nose, had been developing for fifteen years. When once cured by the X-rays, these lesions seldom recur.

De Schweinitz<sup>7</sup> has had four cases of "entire and rapid cicatrization," with no relapse. In two additional cases the results were entirely negative, or possibly the condition was aggravated. In one of the latter, excision was practised with subsequent application of the rays, without

<sup>1</sup> American Medicine, August 9, 1902.

<sup>2</sup> Fortschritt. a. d. Geb. d. Röntgenstrahlen, 1901.

<sup>3</sup> American Medicine, December 13, 1902.

<sup>4</sup> Chicago Medical Reporter, April, 1902.

<sup>5</sup> Medicine, April, 1904.

<sup>6</sup> Trans. Amer. Derm. Asso., 1903.

<sup>7</sup> Personal statements made to Dr. G. Oram King and embodied in an article, "The Value of X-rays in Ocular Therapeutics," Journal of the American Medical Association, September 29, 1906.



recurrence. De Schweinitz concludes the rays should be tried for a certain period, and, if the results are not good, then excision with or without plastic operation should be practised.

Charles Lester Leonard,<sup>1</sup> whose experience has been extensive in treatment of epitheliomas and various skin lesions involving the eyelids, regards it as uniformly and permanently successful. Baker<sup>2</sup> writes that he has had five cases of rodent ulcer, with perfect recovery. One case of special interest had been under observation for ten years; all this time the disease was slowly progressive; not only the eye, but the cheek and temple were involved. The eye was enucleated and, later, X-ray applications were made for a year or more less regularly, resulting in complete cicatrization, with no evidence of recurrence at the end of four years. In a sixth severe case, in which both X-rays and radium were used, a complete cure has been effected, the curative agent being, in Baker's judgment, the Röntgen rays. In eight cases of epithelioma the results have been entirely satisfactory, although in most of the cases the knife was used and followed by the X-rays. There have been no recurrences. Baker had two cases of lupus involving the eyelids, that have been "very greatly improved if not entirely cured by the X-rays."

Hermann Knapp<sup>3</sup> has seen "four temporary results in epithelioma and the like." Stevenson<sup>4</sup> has used the X-rays with success in treatment of lupus of the eyelids only. Newcomet<sup>5</sup> advises me that he has treated about thirty cases, few of which have shown any disposition to recur.

The names of a host of foreign and home workers in ophthalmologic lines or electrotherapy could be added if additional testimony were needed.

J. F. Schamberg<sup>6</sup> treated a case of marked interest,—an epithelioma involving not only the lids, but the conjunctiva as well. A perfect cure was effected, and after two years Schamberg reports no recurrence.

Drs. Hyde, Montgomery, and Ormsby<sup>7</sup> have been very successful in treating fifty-five cases of epithelioma; in a number of the cases the major part of the growth disappeared, in twenty-five cases the lesions have been entirely replaced by scar tissue, and there has been no evidence of recurrence during periods varying from two to nine months.

In surface carcinoma involving deeper tissue their results have not been uniformly satisfactory.

Dr. W. B. Coley<sup>8</sup> reports that out of forty-four cases of epithelioma of the various regions of the face and head only four cases were cured.

<sup>1</sup> Personal statements made to Dr. G. Oram King and embodied in an article, "The Value of X-rays in Ocular Therapeutics," *Journal of the American Medical Association*, September 29, 1906.

<sup>2</sup> *Ibid.*

<sup>3</sup> *Ibid.*

<sup>4</sup> *Ibid.*

<sup>5</sup> *Ibid.*

<sup>6</sup> *Ibid.*

<sup>7</sup> *Journal of the American Medical Association*, January 3, 1903.

<sup>8</sup> *Annals of Surgery*, August, 1905.

Dr. A. D. Rockwell<sup>1</sup> treated two cases of epithelioma, giving forty-five and forty-seven exposures respectively; recovery occurred in both cases.

Dr. G. G. Burdick<sup>2</sup> reports 80 cases of epithelioma, involving the skin only, treated by the X-rays. There were no recurrences. In cases of epithelioma situated at the muco-cutaneous junctions, he advises removal of the glands in the vicinity. After an interval of two years, this method was in 23 cases followed by no recurrence.

Dr. Chas. L. Leonard<sup>3</sup> reported a case of epithelioma of twelve years' standing, which has remained healed for two years.

Dr. Russel H. Boggs<sup>4</sup> treated 12 cases of primary epithelioma; 9 of them were apparently cured, 1 almost cured, 2 very little improved.

Dr. G. P. Girdwood<sup>5</sup> reports 8 cases of typical rodent ulcer; 4 of them completely healed and the other 4 did not. He treated all with the same apparatus and technic. He asks, "Is it simply the difference of constitution, or is there some difference which the microscope does not reveal that should make so great a difference in the result?"

I have had similar failures, and am of the opinion that previous surgical treatment and the special location of the growth are important governing factors. French pathologists believe that different epitheliomas present different histological characteristics.

In the above reports we notice a great diversity of opinion. Some prefer the soft and others the hard tube. Views also vary as to the duration of the séances and their frequency. It is asserted by some that a slight dermatitis is always to be aimed at, in order to obtain the proper action. The great variety of cases encountered will allow of no special technic; the peculiarities of the epitheliomas themselves will frequently dictate the method to be pursued.

Sequeira,<sup>6</sup> who treated 45 cases of rodent ulcer since June, 1901, states that the ulcers healed rapidly and large cavities filled up, but that he had had difficulty with the hard, raised edges. He also observed slight recurrences.

He likewise reported 83 cases of rodent ulcer, 34 of which were healed, and the majority of the remainder were still under treatment. He found that when cartilages of the nose and bones were involved, the condition was unfavorable.

He observed, microscopically, a destruction of the epithelial cells, and in some of them a fatty change occurred and the connective-tissue elements were also stimulated, and this stimulation caused the filling of

<sup>1</sup>New York Med. Journal, April 7, 1906.

<sup>2</sup>Transactions of the American Röntgen Ray Society, 1905.

<sup>3</sup>Ibid.

<sup>4</sup>Ibid.

<sup>5</sup>Transactions of the American Röntgen Ray Society, 1906.

<sup>6</sup>British Medical Journal, September 28, 1901.

cavities and the formation of healthy scar tissue. He also recommends the use of the actual cautery when there is difficulty in causing the hard edge of the growth to disappear.

Joseph T., aged 63, with a negative family history, presented an epithelioma of the dorsum of the hand the size of a half-dollar. (Figs. 227, 228.) Two months before,—*i.e.*, in October, 1902,—after two years of apparent cure, the lesion became painful, ulcerated, and began to spread. The trouble began twelve years ago, with a small papule on the back of the right hand. This grew steadily and slowly, and defied local measures. Patient was subjected to X-ray irradiation, and about two and a half or three years later I reported the lesion healed, but it subsequently reappeared, and at the beginning of the last treatment the ulceration had reached the size of a fifty-cent piece. Surface appears clean, devoid of granulations, with rough and thickened edges. After thirty irradiations the patient improved, but slight dermatitis forbade further treatment. Subsequently the growth was again irradiated, and, at the expiration of sixty treatments in all, the patient made a perfect recovery.

The technic that I usually employ is to irradiate thrice weekly for three weeks, duration of each séance about eight minutes. Crookes (soft) tube, 10 to 12 inches (25 to 30 cm.) distance.

## B. CARCINOMA.

The results sought for in X-ray treatment of carcinoma depend upon several factors:

Depth and rapidity of growth, age and health of the patient, and technic employed.

The deeper the growth the fewer the rays that will reach the cancerous part, most of the rays being absorbed by the skin. We cannot push the treatment as we should desire, for to do so would be to cause a dermatitis that would eventuate in gangrene and necrosis.

In cancers of rapid growth the knife should precede irradiation. To do otherwise is to sacrifice needed radical treatment and perhaps life.

After operation I advise irradiations through the dressings, in order to destroy the cancer cells left by the surgeon. If small subcutaneous nodules should appear four or more months after the operation, they should be irradiated. I have seen very many of these nodules completely removed by this means. Of course the younger and the more robust the patient, the better will be the results of treatment.

I cannot agree with those physicians and pathologists who assert that the X-rays hasten cancerous metastases; their statement, that the rapid disintegration of the cancer-cells (that cannot be eliminated by natural means) must invade surrounding tissue, I believe to be faulty.

Reports of X-ray therapists are widely divergent as to the value of X-rays in the treatment of cancer. I believe that this is largely due



to the use of inefficient apparatus and to errors in diagnosis (benign growths being mistaken for malignant ones), which point to the imperative necessity of examining microscopically, before, during, and after irradiation, sections or scrapings of the growth.

The vacuum of the tube is a matter of prime importance, especially in treating the deeper-seated cancers;—*i. e.*, the vacuum should be high in order to allow of a deeper penetration. In the body cavities,—as the mouth, rectum, vagina, etc.,—I believe in the direct application of the rays, and not by special cavity tubes.

Probably we err too much on the side of safety; apparently the séances are too brief, we too often fearing the production of a severe type of dermatitis. An erythema or slight dermatitis is unavoidable; *per contra*, it is advisable as indicating the particular individual tolerance. I do not endorse the Continental method of massive single doses, but in common with our own operators, I strongly advise and always use short and frequently repeated exposures.

I do not confine treatment to the involved area, as the disease may have invaded surrounding territory. Thus, in treating a mammary carcinoma I irradiate the axillary and subclavian glands on the diseased side and also the opposite breast. This applies to cancer of the tongue, with its associated cervical lymphatics, etc.

*Cancer of the Breast.*—Perhaps, as far as violent malignant disease is concerned, cancer of the breast is more favorably influenced by the X-rays than the same disease occurring in any other part of the body.

Personally, I have encountered quite a large number of cases of carcinoma in various regions. The results obtained varied considerably. Some of the cases showed absolutely no effects under the most persistent treatment, others showed slight improvement, while in only four cases of mammary carcinoma I succeeded in bringing about changes for the better which might be designated absolute cures. I shall report only the cases which gave very good results.

CASE I.—A woman, aged 34, had rapidly developed a carcinoma of the left mammary gland. She readily consented to undergo an operation. Upon palpation we could not discover any enlargement of the axillary glands. The patient's wound granulated rapidly, so that it was apparently healed in the course of four weeks. The pathologist diagnosed the malignant portion as an adeno-carcinoma. Two months after the operation three small nodular masses developed within the old scar; they increased in size and ultimately ulcerated. The patient was advised to undergo X-ray treatment. She was brought to me three months after operation. I exposed the diseased area once daily for one week, inducing by these frequent applications intense inflammation, and from general appearances the area was growing rapidly worse. The exposures lasted for eight minutes each, the tube being twelve inches (30 cm.) distant. The second week all treatments were discontinued. I started on

the third week giving a six-minute exposure every third day, the tube being fourteen inches distant in the beginning, and gradually brought down to eight inches (20 cm.), until the last exposure had been given. The wound had been treated sixteen times before we were able to note any changes. These changes were a lessening of the discharge and the formation of a scab from the drying exudate. The patient suffered absolutely no pain in the beginning of the treatments, but about three weeks subsequently she experienced most excruciating agony. This would lessen considerably after each treatment, and again become worse, when it would subsequently be relieved, and so on. When the discharge had all discontinued, the pain almost entirely subsided. The ulcers seemed to be healing at the edges and the intense induration present also gradually disappeared. In all I gave forty-five treatments and effected a cure. I have watched the patient for nearly sixteen months, and up to the present time no signs of recurrence have been noticed.

CASE II.—The patient was a woman of 62, from whom carcinoma of the breast had been removed. On operation no tuberculous glands could be detected. Six weeks after operation, before the wound had fully healed, the disease recurred, near the seat of the former nipple. The patient received in all thirty-three treatments; irradiation was given every fourth day, lasting six minutes. The disease has not recurred now for eleven months.

CASE III.—A multiple carcinoma occurring in a woman 63 years of age, affecting the breast. The involvement had not been extensive, though sufficient to cause alarm. The tissue between the ulcerated nodules was normal, though the skin was slightly inflamed. The patient had an epithelioma of the lip, fourteen or fifteen years before, operated on, with no signs of recurrence. The patient had been actively treated for four months, and occasionally for the four succeeding months. At first the treatments were given every fourth day, each one lasting from three to eight minutes. By the end of the first four months the carcinomatous field had entirely disappeared, leaving small scars very difficult of detection.

CASE IV.—Mrs. B., carcinoma of the right breast. She was operated upon by Dr. M. P. Warmuth, on September 29, 1903, and X-ray treatment was instituted January 1, 1904. I gave her twenty-five treatments, thrice weekly. Up to the present time there has been no recurrence.

CASE V.—Miss J. L., age 24, a nurse, with cancer of right breast; her mother died of mammary carcinoma. Dr. Warmuth operated in November, 1904, and I instituted X-ray treatment in January, 1905. In the meanwhile she married. On October 10, 1905, she noticed a swelling on the left breast. I gave her ten treatments before the operation and subsequently the left breast was also removed. Post-operative treatment was given for a period of three weeks. She is now in good health.

CASE VI.—Mrs. C., was operated upon by Dr. John B. Deaver, on



November 27, 1905, for cancer of the right breast, and referred to me by Dr. Taylor. I began X-ray treatment one month after the operation, and gave her three exposures weekly for three months, duration ten minutes. Anodal distance ten inches. Both breasts and axillary regions were irradiated. At present I treat her once monthly. She is perfectly well and there is no sign or symptom of a recurrence.

CASE VII.—Mary Moore, age 51, single, housewife. Family history negative. Duration of the present disease ten months (secondary). The trouble began as a small white papule under the left axilla. Three months later the patient was operated upon for the growth, which had increased greatly in size and extent; surgical measures were only partly successful. The patient was treated for three months, thrice weekly. Eventually the part healed, but the patient died from metastatic involvement.

CASE VIII.—Kate Quinn, age 61, married, housewife. She was run down by a bicycle eleven years before coming to me, and a year later there appeared over the site of the traumatism a small growth, that increased in size until it involved nearly all of the right breast; ulceration occurred and spread rapidly. There was no apparent involvement of the adjacent lymphatics. Treatment was instituted June 22, 1904; forty-five exposures were given, each of ten minutes duration. The pain, discharge, etc., disappeared, but four months later the patient expired. Death was due to general infection.

H. Gocht<sup>1</sup> reported two cases of carcinoma of the breast exposed to the influence of the rays. Both of these cases had been regarded as inoperable. No cures, however, were effected, though in one of the cases pain was almost entirely relieved. The other case died before any improvement had been discerned.

George G. Hopkins<sup>2</sup> reported two cases of carcinoma of the mammary glands treated by the rays. The first case was entirely cured after thirty-two treatments had been given. The second case only showed improvements, such as lessening of discharge and pain and partial healing of the ulcer.

Ayers<sup>3</sup> also reported the results obtained in two cases of mammary carcinoma. The first had been operated on, and, before healing had been completed, areas of recurrence of the disease were noticeable. These areas were exposed daily for four minutes during three and a half months. Healing was absolutely complete, with no symptoms. The second case had a great deal of induration, ulcerating at three areas. The axilla had also been much involved. The results obtained were a decrease in size of the induration, considerable lessening of the ulcerating discharge, and the disappearance of all pain.

<sup>1</sup>Fortschr. a. d. Geb. d. Röntgenstrahlen, 1897, i. p. 14.

<sup>2</sup>Philadelphia Medical Journal, 1901, viii. p. 404.

<sup>3</sup>The Kansas City Medical Index-Lancet, 1902, xxiii. p. 18.



Chisholm Williams<sup>1</sup> reports a woman, 42 years old, single, having a scirrhus form of recurrent ulcerative carcinoma of the breast treated by X-rays, twice a week, five minutes each sitting; in all 28 exposures were given. There has been no recurrence during the past four and a half years, and the patient is still in excellent health. He also reports a similar case in which lumps in the axillary region disappeared and remained cured for three years.

Dr. S. M. McCollin<sup>2</sup> reports a recurrent carcinoma of the breast with an ulcerated surface five by eight inches. The patient was relieved of all pain, skin formed over the ulcer, and life was prolonged for nearly one year.

Dr. G. H. Stover<sup>3</sup> says that in his own experience prophylactic treatment has resulted in failure. He believes that this may be due to the treatment not being sufficiently vigorous or continued long enough. He thinks anti-operative treatment is of benefit. Nor is Stover alone in this view, a number of skiagraphers sharing the same opinion.

Dr. R. H. Boggs<sup>4</sup> observed 23 cases of carcinoma of the breast; 15 of these patients were operated upon and a recurrence had taken place when they came for X-ray treatment. Up to the present time, 8 patients have died, 2 have been lost sight of, and the other 13 are living; 7 of these are apparently cured, 2 are under treatment, and the other 4 are gradually becoming weaker. Some of them were treated three years ago, but, of course, this is still too short a time to say that there will be no recurrence.

Dr. Joseph F. Smith<sup>5</sup> says that in carcinoma of the breast he has seen small recurrences along the line of incision or small nodular involvements disappear under the use of the rays. He has not seen any patient in whom a large primary carcinoma of the breast disappeared under the use of the X-rays.

Dr. G. G. Burdick<sup>6</sup> reports a cure of 18 cases of carcinoma. In 14 cases the tumor and enlarged glands disappeared.

Dr. W. B. Coley<sup>7</sup> treated 36 cases of carcinoma of the breast. In only one instance did the tumor disappear, while in every other case there was a recurrence.

Dr. A. D. Rockwell<sup>8</sup> reports that in a case of scirrhus of the breast, after 24 post-operative exposures there was no evidence of return three years later.

<sup>1</sup> Archives of the Röntgen Ray, October, 1906.

<sup>2</sup> Proceedings of the Philadelphia County Medical Society, October 31, 1904.

<sup>3</sup> Transactions of the American Röntgen Ray Society, 1906, p. 150.

<sup>4</sup> Ibid.

<sup>5</sup> Ibid.

<sup>6</sup> Ibid.

<sup>7</sup> Annals of Surgery, August, 1905.

<sup>8</sup> New York Med. Journal, April 7, 1906.

Dr. Lassar<sup>1</sup> stated that he had had only three failures out of hundreds of cases of cancers that he submitted to the rays.

He recognizes<sup>2</sup> the limitations of treatment, stating that one-fifth of an inch is the extent of its effective therapeutic penetrating power.

Comas of Liston has had similar favorable results.

Wohlgemuth<sup>3</sup> witnessed the disappearance of a cancer of the breast in a woman of 75 after 72 exposures thrice weekly.

Unger, of Berlin, and Sjögren, of Stockholm,<sup>4</sup> know of no case of cure of mammary cancer.

Djemil Pasha<sup>5</sup> treated six cases of cancer; three cases were cured and three improved.

W. Johnson and W. Merrill<sup>6</sup> treated seven cases of carcinoma, all of which were inoperable; none showed any improvement beyond relief from pain. They all ended fatally.

*Cancer of the Sternum.*—Ferguson<sup>7</sup> reported a case of scirrhus of the sternum, which had been declared inoperable. The Röntgen rays were applied nineteen times, each exposure lasting twenty minutes. Three weeks after the last treatment the growth had almost entirely disappeared. After the sixth treatment the excruciating pain wholly ceased. Following the healing of the ulcerated field, there was noticed a slight involvement of the axillary glands.

*Cancer of the Œsophagus.*—Pusey<sup>8</sup> records the following case of carcinoma of the œsophagus, treated by the X-rays: "Man, age 56, referred to me by Professor W. S. Halsted, of Johns Hopkins University, May 7, 1902. An obstruction in the œsophagus had been located nine inches from the teeth. At first a clinical diagnosis of carcinoma was made. Subsequently, Dr. Halsted informs me, a piece of tissue was removed through the œsophagoscope and the diagnosis of adenocarcinoma was made microscopically. Vigorous X-ray exposures were begun over the upper part of the chest May 7, 1902, and from that time to the present he has had exposures daily except Sundays, either over the chest or back, the exposures being changed as erythema developed. There was prompt disappearance of the discomfort and pain in the chest, and there was a gradual improvement in his swallowing. Six weeks after beginning the exposures, he had gained nine pounds in weight, his pain had disappeared, and he was having no difficulty in swallowing."

<sup>1</sup> Röntgen Congress, Berlin, 1905.

<sup>2</sup> Journal of American Medical Asso., p. 79.

<sup>3</sup> Röntgen Congress, Berlin, 1905.

<sup>4</sup> Ibid.

<sup>5</sup> Revue de Chirurgie, Paris, xxv., No. 1.

<sup>6</sup> American Medicine, August 9, 1902.

<sup>7</sup> British Medical Journal, 1902, i. p. 265.

<sup>8</sup> The Röntgen Rays in Therapeutics and Diagnosis.

*Cancer of the Larynx.*—W. Scheppegrell<sup>1</sup> reports a case of carcinoma of the larynx in which a complete cure was obtained by the rays alone. The growth involved the left wall and left vocal cord. A high-tension coil was employed, and a tube of medium vacuum was selected in order to gain some penetration. The face and chest were protected, but the neck was freely exposed in the hope that any involvement of surrounding glands might be influenced by the treatment. At first the exposures lasted ten minutes and were repeated daily for twenty days. The anode was brought to a dull-red heat, and the vacuum was maintained about the same, from the beginning to the end of the treatment. At the end of three weeks, congestion seemed more marked and the tumor unchanged; pain, however, had disappeared after the second exposure. Ten days later it was found that the tumor and most of the symptoms had disappeared. Treatment was carried on for ten days, by which time the ulcers were healed. The patient, when seen three months later, seemed in good condition; the aphonia had been practically overcome by compensatory over-action of the other cord.

Dr. D. Bryson<sup>2</sup> believes that not a single case of laryngeal cancer has been reported cured, but few cases have been thus treated. In one case treated by Dr. W. J. Morton for the author, apparently good results were produced on the growth, but the patient died of Bright's disease after twenty applications of the rays.

*Cancer of the Stomach and Bowels.*—Dr. P. M. Pilcher<sup>3</sup> reports an inoperable carcinoma of the stomach in a woman of 56. Three treatments of fifteen minutes each were given weekly; they began August 1, 1903, and at the time of the report the patient was able to eat and was free from pain.

Dr. S. M. McCollin<sup>4</sup> reports a case of carcinoma of the stomach in which the swelling entirely disappeared and the patient was relieved of all clinical evidence of the disease.

Dr. Finley R. Cook<sup>5</sup> reports that in carcinoma of the intestines, where life had been threatened with intestinal obstruction, all symptoms of obstruction have been relieved, the tumor reduced in size, and life prolonged for variable periods.

Pusey says that in carcinoma of the rectum the only hope in the application of the rays lies in the decrease of pain, the checking of the discharge, and the shrinkage of the growth.

*Cancer of the Uterus.*—In applying the rays for cancer of the uterus, I introduce a speculum and protect the thighs and lower abdomen with a sheet of lead, exposing only the vulva. I employ a medium tube, at

<sup>1</sup> New York Medical Journal, December 6, 1902.

<sup>2</sup> The Laryngoscope, December, 1902.

<sup>3</sup> Brooklyn Medical Journal, April, 1904.

<sup>4</sup> Proceedings of the Philadelphia County Medical Society, October 31, 1904.

<sup>5</sup> International Journal of Surgery, October, 1903.



a distance of eight to ten inches (20 to 25 cm.), thrice weekly, exposure ten minutes' duration. The Crookes tube with the speculum attached, encased in a shield (Fig. 229), is far superior to cavity tubes (Figs. 230, 231), as the latter lack the effective quality of the Crookes tube. X-ray workers, however, employ these tubes. If vaginal dermatitis is threatened, the rays may be passed on alternate days through the lower abdomen.

Dr. James P. Marsh,<sup>1</sup> of Troy, N. Y., cited a case of a woman, aged 55, referred to him for hysterectomy because of an extensive carcinoma

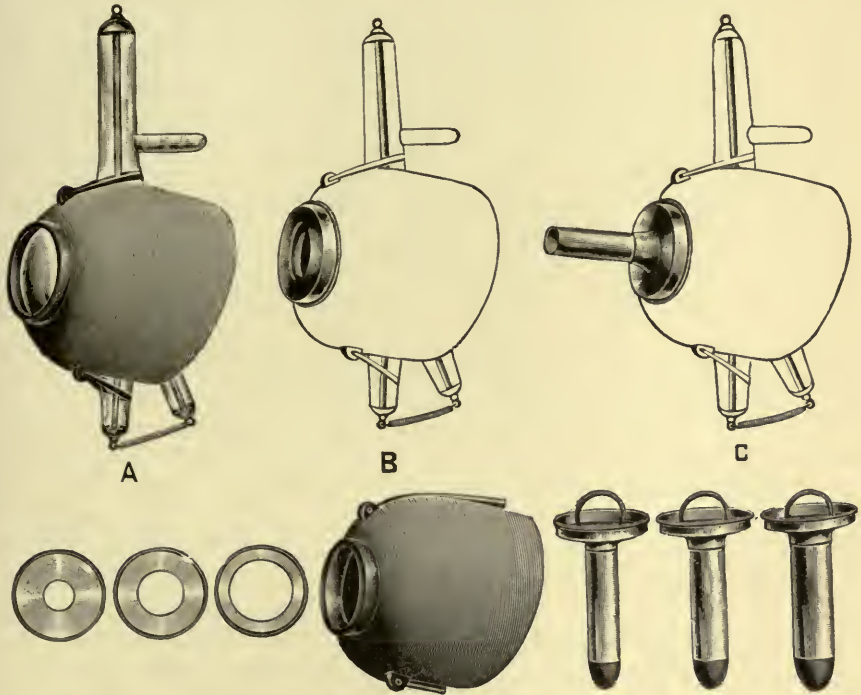

FIG. 229.—TUBES AND RUBBER TUBE SHIELDS FOR THERAPY OF THE BODY CAVITIES.—A, the rubber tube shield, encasing the tube and tied to it; B, showing the size of the opening governed by the diaphragm; C, showing speculum attached. (R. V. Wagner Co.)

of the cervix. He applied the rays alternately over the suprapubic region and the vagina, using a very soft tube. The treatment was given for ten minutes. After twenty or thirty treatments there was a marked improvement in her condition. All of the symptoms had disappeared; she was feeling well and gaining in weight.

*Therapeutic Action of the X-rays in Cancer.*—Dr. John G. Clark,<sup>2</sup> at a meeting of the Medical Society of Pennsylvania, said: "During the

<sup>1</sup> Journal American Med. Association, Jan. 17, 1903.

<sup>2</sup> The Pennsylvania Medical Journal, April, 1904.

last year Dr. Matthew D. Mann, in a personal recital of his own experience, first directed my attention to the possibilities of Röntgen-ray

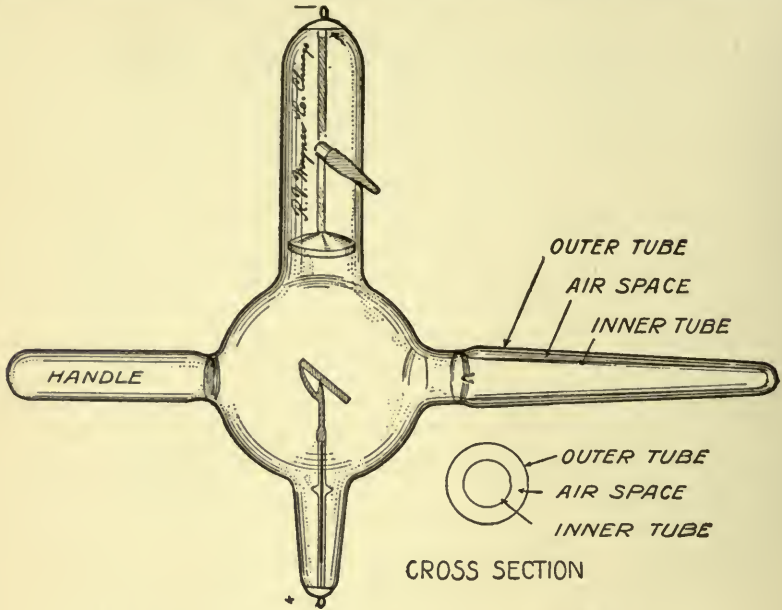

FIG. 230.—Pennington's treatment (cavity) tube. (R. V. Wagner Co.)

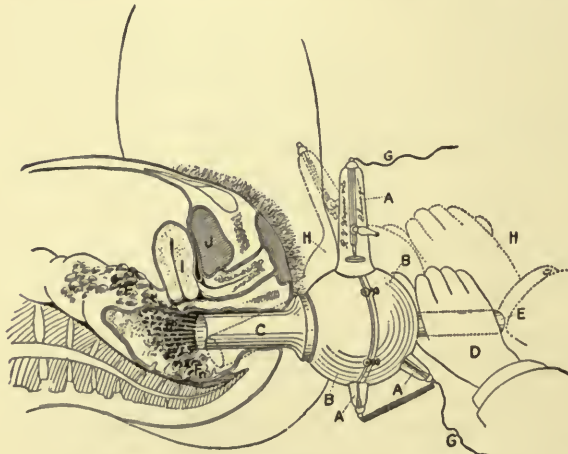

FIG. 231.—Cavity tube applied. (R. V. Wagner Co.)

treatment in inoperable cases and in those in which there is a recurrence after operation. In the literature, which as yet is not at all well defined concerning the active effects of this agent, there appears a diversity of opinions; some claiming that the curative action arises from a

stimulation of the nutrition of the part rather than from an actual attack upon the cancer-cells, whereas, others believe that the rays act destructively upon the cells by diminishing their growth, thus permitting the underlying connective tissue to reassert its functional activity and reconstruct the deficiencies produced by the invasion of the new growth."

Codman, in commenting upon an extensive number of cases treated in the Massachusetts General Hospital, claims that the beneficial effects of this form of treatment arise from the stimulation of the nutrition of the surrounding parts, rather than from a direct specific effect upon the growth.

In the microscopic study of the tissues after the Röntgen-ray treatment, a number of observers agree in general as to the structural changes. They have found a necrosis of the cancer-cells and trabeculæ, at times fatty degeneration, an increase of elastic tissue, and a tendency to the occlusion of vessels by a thickening of their inner walls. To the latter effect is probably attributable the diminution of hemorrhage frequently noted in these cases after the treatment is well under way.

### C. SARCOMA.

What has been said relative to the results obtained in epithelioma and carcinoma applies with equal force to sarcoma. I cannot believe that many X-ray operators have achieved brilliant results with the rays in this disease. I have found that irradiations in sarcomatous affections are too often futile. Below are given some of the more interesting reports upon the subject.

Ricketts<sup>1</sup> reports a case of melanotic sarcoma of the chest wall. The tumor had much decreased in size and the pain had almost totally disappeared. The patient died in the mean time.

Carl Beck<sup>2</sup> reports a case of melanotic sarcoma of the groin and the thigh, recurring after operation. Vigorous X-ray treatments checked the course of the disease.

S. W. Allen<sup>3</sup> reports a case of sarcomatous growth of the tonsil. The operator exposed the swelling to the influence of the rays, with a resulting decrease in the size of the tumor, and at the same time the patient could articulate words with much greater ease. Entire cure had not been attained when this report was made.

F. Williams<sup>4</sup> speaks of a patient who had received fourteen treatments for sarcoma of the arm, each exposure lasting from twelve to twenty minutes, the tumor being exposed twice in one week. The

<sup>1</sup> Journal of the American Medical Association, 1900, vol. xxxiv. p. 76.

<sup>2</sup> New York Medical Journal, 1901.

<sup>3</sup> Boston Medical and Surgical Journal, 1902, p. 431.

<sup>4</sup> The Röntgen Rays in Medicine and Surgery.



induration had disappeared almost entirely, the swelling had diminished considerably, and the venous discoloration over the tumor had given way to the normal hue of the skin.

Scholtz<sup>1</sup> reports the results obtained in the treatment of two cases of multiple sarcomata of the skin. He states that under active applications small nodules of the integument disappeared entirely. Jamieson's case of mycosis fungoides which was treated with the X-rays showed very marked improvement in every respect.

Dr. George Ereyt Shoemaker<sup>2</sup> reports the case of a woman who had sarcoma of the abdominal wall, and probably also of the pelvic viscera, which disappeared under treatment. On operation it was found that the rectum, the uterus, and the left tube and ovary were massed together by an apparent infiltration, but had a certain range of motion. The tumor in the lower abdominal wall was united to this mass by a process of thickened tissue a little to the left of the median line. The whole appearance suggested a new growth, which it was thought unwise to remove. The incision was closed, and a cut made directly into the suprapubic growth. Examination of the piece removed for that purpose showed that the mass was sarcomatous. Treatment by the Röntgen rays was begun after the healing of the upper wound. This treatment continued for about nine months in all. The total number of exposures was forty-nine. The improvement was remarkable. A year after coming under observation the infiltration of the abdominal wall, the pain, and the soreness were entirely gone.

In a case reported by Richmond,<sup>3</sup> the patient had a swelling which crowded the liver and other organs forward and inward. A diagnosis of sarcoma was made. After treatment with the X-rays for nineteen consecutive days the temperature had decreased to normal, night-sweats were lessened, the tumor had apparently ceased to grow and seemed softer, and the patient was generally improved. She was then sent to the hospital, where the treatment was continued, and at the end of nine weeks the growth had entirely disappeared, as far as could be determined by bimanual examination.

McMaster<sup>4</sup> reports five cases of sarcoma in which treatment with the X-rays proved entirely successful.

Dr. L. Webster Fox,<sup>5</sup> of Philadelphia, had his attention called to X-ray treatment in epithelioma of the lids. A year and a half ago he had a case of sarcoma of the orbit; the diagnosis was confirmed by several colleagues and by the microscope. The case received forty-eight

<sup>1</sup> *Archiv f. Derm. u. Syph.*, 1902, lix. p. 42.

<sup>2</sup> *American Medicine*, December 26, 1903.

<sup>3</sup> *Journal of the American Medical Association*, June 10, 1903.

<sup>4</sup> *Canada Lancet*, February, 1903.

<sup>5</sup> *Journal of the American Medical Association*, December 17, 1904.

applications of the X-rays before the disappearance of the growth. There was no recurrence.

J. G. Chrysopathos<sup>1</sup> operated on a woman who had a large, rapidly growing tumor of the right ovarian region; finding it to be a sarcoma (a diagnosis which was confirmed by microscopic examination), he began to treat it with Röntgen rays. She was treated two or three times weekly, and after about eight months was discharged as cured. Neither abdominal nor vaginal examinations offered the slightest abnormality. She is now treated about once every two or three weeks, and has been well for some months.

The tumor in the case cited by Skinner<sup>2</sup> was situated in the lower part of the abdominal wall, in the region of the cicatrix resulting from a laparotomy, performed three years before, for what was regarded as a fibroid uterine tumor. The fibro-sarcoma was of the size of a cocoanut, filling up the entire iliac fossa, extending nearly to the umbilicus and two inches beyond the median line to the left. The tumor was very firmly fixed and seemed to involve the abdominal wall. Erysipelas toxins were used for ten months. During the first two months the growth decreased more than half in size, and for a long time thereafter, while there was no decrease, there was no distinct growth. Later on the influence of the toxins seemed to have become lost, and there was a slow but gradual increase in size. X-ray treatment was then begun. The patient received one hundred and thirty-six exposures within seven hundred and thirty-nine days; two applications were given in the course of every five days at the beginning of the treatment, and later on, one in five days, fifteen days, and thirty-seven days. Twenty-eight months after beginning the treatment, the patient had increased considerably in weight and the tumor had entirely disappeared.

Béclère<sup>3</sup> reports the case of a patient affected with sarcoma of the floor of the orbit who was cured by X-rays. The disease had lasted four years. Two operations had been performed, the last one including removal of the eye. All other methods of treatment had failed, but improvement set in as soon as radiotherapy was employed. Histologically, the tumor was found to be a malignant sarcoma. Béclère reports an additional case of orbital sarcoma cured by X-rays.

Kienböck<sup>4</sup> reports a sarcoma cured by X-rays. This case is of very unusual interest. A growth, having appeared in the nose seven years before, in spite of operations oft repeated, had invaded the adjoining structures and produced exophthalmos on both sides, with subsequent optic atrophy. Pain ceased after the first treatment, and after thirteen

<sup>1</sup> Münch. med. Wochens., 1, 50.

<sup>2</sup> Archives of Electrolgy and Radiology, October, 1904.

<sup>3</sup> Gaz. des Hôp., June 14, 1904.

<sup>4</sup> Quoted by Dr. G. Oram Ring, "The Value of X-Rays in Ocular Therapeutics," Journal American Medical Association, September 29, 1906.

applications the growth (an endothelial sarcoma) entirely disappeared. The eyes resumed their normal appearance and vision partly returned. Crossman<sup>1</sup> reports a similar case which had almost entirely disappeared under the X-rays. Theobald<sup>2</sup> has had one case of marked exophthalmos (unpublished) with the diagnosis of inoperable sarcoma of the orbit—a diagnosis in which two other surgeons concurred. Under the X-ray treatment the case rapidly improved and after a lapse of seven months seemed to be cured.

W. B. Coley<sup>3</sup> treated 167 malignant growths, scattered over many parts of the human body, and arrives at the conclusion that, while the X-rays are of inestimable value in skin cancers, nevertheless the latter often recur, and that undoubtedly surgery is in these cases far preferable. He is opposed to the use of the rays in deep-seated carcinomas and sarcomas, believing their value very slight and temporary. Where the neoplasm had apparently disappeared, metastases quickly occurred. He believes that irradiation is palliative in those cancers that are for any reason inoperable. He asserts that post-operative irradiation rests purely on theoretical grounds and needs further study as to its value or usefulness in these cases.

I believe that in many instances, where brilliant results were achieved in irradiation of sarcomas, in all probability there was a mistake in the diagnosis and a less malignant affection was present, or else the operators were a little too enthusiastic when making their reports.

George C. Johnston<sup>4</sup> reports three cases of inoperable and recurrent sarcoma successfully treated by the X-rays. The diagnoses were made clinically and pathologically. No auto-intoxication occurred.

Djemil Pasha, of Constantinople,<sup>5</sup> reports that a case of sarcoma of the breast seemed rather aggravated by treatment.

Dr. W. B. Coley<sup>6</sup> treated 68 cases of sarcoma. He obtained complete disappearance of the tumor in five of them.

Dr. Russell H. Boggs<sup>7</sup> treated five cases of sarcoma. In two of them the growth was reduced in size, but improvement was temporary. Later, both patients died.

G. G. Burdick<sup>8</sup> treated 34 patients; 18 are considered cured. The tumors disappeared completely and are giving no trouble whatsoever.

<sup>1</sup>Quoted by Dr. G. Oram Ring, "The Value of X-Rays in Ocular Therapeutics," *Journal American Medical Association*, September 29, 1906.

<sup>2</sup>Ibid.

<sup>3</sup>New York Medical Journal, April 7, 1906.

<sup>4</sup>Journal of Advanced Therapeutics, 1904, p. 648.

<sup>5</sup>Revue de Chirurgie, Paris, xxv., No. 1.

<sup>6</sup>Annals of Surgery, August, 1905.

<sup>7</sup>Transactions of the American Röntgen Ray Society, 1905, p. 115.

<sup>8</sup>Ibid., p. 112.





FIG. 232.—SARCOMA OF THE LEG.—1 and 2 show areas of recurrence ; 3 indicates the part that I irradiated.

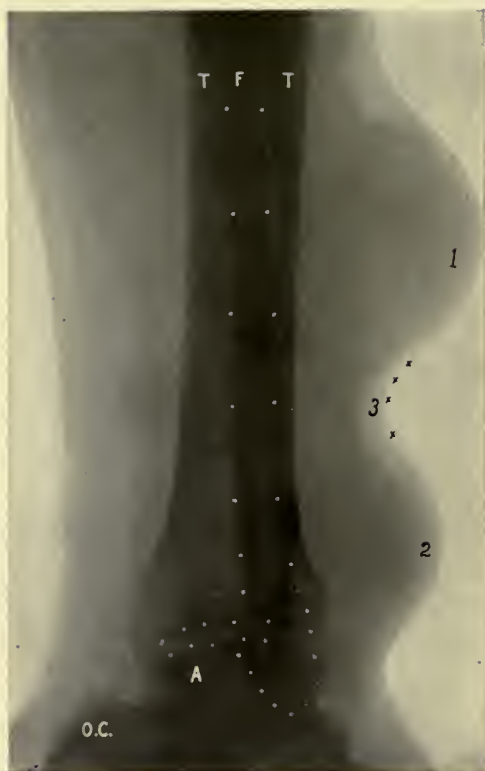

FIG. 233.—Skiagraph of the same.

The patients are following their usual vocations. I think Dr. Burdick has overstated these facts.

Dr. Charles R. Dickson,<sup>1</sup> of Toronto, exposed within one year a case of recurrent sarcoma 48 times to the rays. The symptoms disappeared completely and, though the case was discharged about one year ago, the sarcoma has not shown any signs of returning.

All of my cases ended fatally, although I have seen the same temporary improvements. In one of my cases a sarcoma of the leg showed the slow progress of the disease, and repeated recurrences even under vigorous X-ray treatment were noted.

I treated a patient, aged 30, who in the spring of 1900 noticed a small tumor of the right leg about two inches above the ankle. The neoplasm was removed one month later and diagnosed microscopically as a sarcoma. Three years later there was a recurrence. I then proceeded to irradiate the part. I treated him for six weeks, thrice weekly, each treatment of ten minutes' duration. The patient completely recovered. In June, 1905, the vicinity of the scar became sarcomatous and was operated upon by Dr. Babcock. In September, 1905, he returned to me, as the sarcoma was again recurring around the former seat, and, because he complained of pains in the chest, I skiagraphed the latter and found in the lung sarcomatous metastases. The patient became very despondent and ended his life. (Figs. 232 and 233.)

### III. Constitutional Diseases.

#### A. TUBERCULOSIS.

The value of the X-rays in tuberculous affections is at present undetermined. The varying stages of the disease, the inexactness of the reports recorded, and the particular behavior of the malady in the different structures invaded, make it advisable to append the following reports from experienced investigators.

Bergonié and Teissier<sup>2</sup> give some of the results obtained in experimenting with the X-rays upon tubercle bacilli. They conclude that animals infected with tuberculosis and subjected for varying periods of time to the action of the rays die, for the most part, without any appreciable change in the lesions and without any retardation in the course of the disease.

Dr. Keemon Dunham<sup>3</sup> said that he had found that the X-rays do not affect the tubercle bacillus to any appreciable extent. He believes that the favorable results obtained by treating tuberculous patients are not due to a destruction of the bacillus, but to the stimulation of

<sup>1</sup>Journal of Advanced Therapeutics, 1904, p. 654.

<sup>2</sup>Arch. d'Électricité Médicale, 15, xi., and 15, xii., 1898.

<sup>3</sup>Proceedings of the American Röntgen Ray Society, 1903.



the tissues. He had obtained good results by simply wrapping the patient in a coil of copper wire connected with one pole of a high-frequency current.

Chisholm Williams,<sup>1</sup> in an article read before the members of the Electro-Therapeutic Sub-section of the British Medical Association in 1901, stated that, of the forty-three cases of pulmonary tuberculosis treated by the X-rays, only three had died, the immediate cause of death being pneumonia, tuberculosis of kidney, and lardaceous disease. During the treatment the temperature of the patient uniformly rose, the rise depending upon the duration and strength of the treatment. Night-sweats increased at first, but gradually disappeared. The number of bacilli in the sputum increased early in the treatment, but later on formed clumps, became short and stumpy, took a stain more readily, and later in the treatment began to decrease. The disease has been arrested when the patient can take daily treatments of half an hour or more without showing a rise of temperature during the treatments.

Dr. Russell H. Boggs<sup>2</sup> cited six cases of tuberculosis treated by him with the X-rays. One of the cases has remained cured for over a year. One case died from an intercurrent affection, and the other four are decidedly improved in every way.

Dr. J. D. Gibson<sup>3</sup> cited a case of tuberculosis complicated by a very large cirrhotic liver. After a treatment of six weeks the symptoms were markedly improved. The treatment was discontinued; the patient went home and died. While the rays do not cure, yet they improve every case, even the most desperate and hopeless.

Rudis-Jieinsky<sup>4</sup> states that he has employed the X-rays together with other forms of treatment in 19 selected cases of pulmonary tuberculosis. Of these he states, in one year, one died.

Drs. Boido and Boido<sup>5</sup> report fourteen cases of tuberculosis treated by means of the X-rays. The treatment had been conducted in Tucson, Arizona, which has an altitude of 2300 feet, and a climate that is warm and dry. The fourteen cases reported were all Mexicans, afflicted with pulmonary tuberculosis in varying stages of disease. It is their opinion that in treating such cases it is beneficial to the patient to employ a tube which produces rays that induce a dermatitis, claiming that such rays are of real therapeutic value. In making the exposures the vacuum tube was placed 3 to 4 inches (8 to 10 cm.) distant from the skin. Exposures were made both anteriorly and posteriorly, allowing five minutes for each side of the chest. After these exposures ten of the fourteen cases had been

<sup>1</sup> Archives of the Röntgen Ray, August, 1903, p. 48.

<sup>2</sup> Ibid.      <sup>3</sup> Ibid.

<sup>4</sup> The New York Medical Journal, March 2, 1901, pp. 364, 365.

<sup>5</sup> American Electro-Therapeutics and X-Ray Era, February, 1903.

relieved of the pulmonary pain. The number of exposures varied in each case. Their reports show that three deaths occurred in three years, and the remaining eleven are still living.

J. B. Ransom<sup>1</sup> reports treatment of forty cases of tuberculosis in the lungs and other parts of the body. He specifies that the Röntgen rays, and also the ultra-violet rays, are especially indicated for treating tuberculous lesions located more or less superficially. As regards deep-seated pulmonary lesions the number of such cases treated is entirely too small and the time that has elapsed is too brief to arrive at any definite conclusions. He believes that the Röntgen rays may soon prove to be a valuable therapeutic agent in this class of diseases. He also asserts that pain is relieved and sleep is permitted; the local circulation is stimulated and expectoration is considerably lessened.

Hahn<sup>2</sup> states that Rieder had applied the X-rays to the thorax of a patient suffering with a chronic form of pulmonary tuberculosis, and the results obtained were not encouraging in any way as was primarily expected.

G. E. Pfahler<sup>3</sup> says that early in the history of the X-rays physicians noted relief from pain, and to a degree from other symptoms, in cases of tuberculosis of the joints which had been examined repeatedly by means of the rays. He says that J. B. Murphy treated two cases of tuberculosis of the knee-joint in which the synovial membrane was involved. Both of the joints had been treated by injections without improvement. One patient in whom the effusion had persisted nine months was discharged as recovered after 21 days in the hospital, the effusion having disappeared. Murphy also reports three cases of spinal tuberculosis treated with the X-rays. The first case was one in which the patient developed paraplegia. Pus and tuberculous débris, which established the diagnosis, were removed with a hypodermic needle. After the third application of the rays the pain disappeared, and after twenty-five applications the paraplegia was cured. A second case was one in which laminectomy had been performed a year before. The patient was worse after the operation, and a sinus was left, but this healed completely after twenty applications of the rays. The paraplegia in this case was not improved. The third case was that of a paraplegic, whose pain was controlled by large doses of morphia. Two exposures relieved pain, and after the twenty-third irradiation he got about on crutches.

Henry K. Pancoast<sup>4</sup> mentions the results obtained in the treatment of deep-seated lesions of the larynx, lungs, peritoneum, joints, and spine with the X-rays. He found that tuberculous laryngitis may be aided and even cured by X-ray treatment, provided there can be brought about an

<sup>1</sup> Medical Record, February, 27, 1904.

<sup>2</sup> Fortschritte a. d. Geb. d. Röntgenstr., B. iii., H. 3, p. 119.

<sup>3</sup> Philadelphia Medical Journal, February 14, 1903.

<sup>4</sup> Therapeutic Gazette, August, 1905.

improvement in the primary pulmonary condition. Too vigorous treatments will cause a reaction which may be carried to an unfavorable degree; therefore, great care is necessary in determining the proper dosage in each case. Pulmonary lesions in selected cases may be benefited probably, but even greater precautions should be observed. He does not consider Finsen-light applications of any value in treating laryngeal lesions. Only the most powerful lamps need be tried, and such exposures are of value only in lessening or retarding a skin reaction from the X-rays.

Ausset and Bedart<sup>1</sup> treated a case of tuberculous peritonitis in a girl, nine years of age, by tapping and abdominal section, but with negative results. During this treatment her condition grew steadily worse, and the tuberculous masses in the abdomen steadily enlarged. On March 7, she was first subjected to the X-rays, the Crookes tube being placed 20 cm. from the surface of the abdomen for ten minutes, two days later at 13 cm. Throughout the month the treatment was continued every two or three days. During most of the following month the treatment was unavoidably discontinued. During the latter part of May there was absolutely no abdominal effusion. From this time on, she steadily improved, gaining in weight and strength, until she became apparently well.

Southgate Leigh<sup>2</sup> cites a case of tuberculosis of the elbow-joint. The joint had been exposed to the rays for a period of two hours, and as often as two or three times in a week. After twelve hours' exposure the inflammatory process entirely disappeared; no recurrence appeared in the eighteen months that had since elapsed.

Dollinger<sup>3</sup> reports for Kirmisson a case of tuberculosis of the wrist-joint. The part had been exposed for ten minutes daily for a period of two and a half months. The result was an improvement, and by the subsequent application of electricity the part was absolutely cured.

Tousey<sup>4</sup> is of the opinion that judicious application of the X-rays, or of the ultra-violet rays and high-frequency currents, is indicated in every case of tuberculosis, especially tuberculosis of the larynx. One case, in point, is reported in which the treatment was remarkably successful. The expectoration ceased in three weeks; there was great improvement in the voice, marked gain in strength, normal temperature, and a gain in body weight of about three pounds. The local condition also has improved, an area of infiltration has diminished, and the abrasions have healed with a whitish appearance, which may be due to cicatricial tissue. The treatment consisted first in exposure to the X-rays once every

<sup>1</sup> L'Echo Méd. du Nord, No. 46, 1898.

<sup>2</sup> Reported by Werner in the Fortsch. a. d. Geb. d. Röntgenstrahlen, B. iii., H. 3, pp. 122, 123.

<sup>3</sup> Fortsch. a. d. Geb. d. Röntgenstr., B. ii., p. 72.

<sup>4</sup> Medical Record, September 3, 1904.



four or five days ; exposure to the Cooper-Hewitt light and application of high-frequency currents once in each interval between the X-ray applications.

Dr. M. C. Rice<sup>1</sup> reported the case of a woman, whose mother and sister had both had enlarged glands, suppuration having occurred in the case of the mother. The patient had a chain of enlarged glands extending from the ear to the clavicle ; the largest one, situated below the ear, was the size of a hen's egg. These glands had been somewhat enlarged for five years, but had been growing rapidly for four months. The patient had been taking iodides for some time. After three months of treatment with the high-frequency current, by means of the Tesla coil and static machine, with only slight improvement, Röntgen rays were substituted, after which the patient improved. After five months' treatment the glands could scarcely be felt.

Dr. E. H. Grubbe<sup>2</sup> has had under treatment more than thirty cases of tuberculosis of the cervical lymph-glands, most of them in children, and superficial. From the results he obtained, he feels that he can make great claims for the Röntgen-ray treatment of this condition. Of course, he prefers to treat them when they are primary cases, because one cannot get such good results after the disease has extended to the deep glands nor after surgical interference.

Dr. Russell H. Boggs<sup>3</sup> asserts that the results obtained by the Röntgen rays in the treatment of tuberculous adenitis compare favorably with those obtained by any other method. A large proportion of the cases can be apparently if not permanently cured. Several cases have remained cured for over four years. Improvement is not attained, as a rule, until at least twelve treatments have been given. There are exceptions, however, one patient being improved after four treatments, and others not improving until after twenty-five or more exposures. A permanent cure should not be expected until after at least three months' treatment. He advised that in treating these cases the apices of the lungs should also be rayed. To be beneficial, treatment must be energetic.

In tuberculous adenitis that has advanced to suppuration, my preference is to have the patient submit to surgical interference and to the subsequent employment of irradiations. Early in tuberculous adenitis, the rays are useful in aborting the affection by the formation of fibrous tissue within and around the gland.

Dr. James B. Bullitt,<sup>4</sup> in a "comparison of Röntgen-rays and surgical treatment of tuberculosis," says : "I have collected 518 cases of surgical forms of tuberculosis, reported by forty-eight observers ; most of these have come through personal communication ; a few have been

<sup>1</sup>Transactions of the Röntgen Ray Society, 1905.

<sup>2</sup>Ibid.

<sup>3</sup>Journal of the American Medical Association, September 15, 1906.

<sup>4</sup>Transactions of the American Röntgen Ray Society, September, 1904.

collected from the literature. The following is the tabulated list showing the number of cases of each kind and the number and percentage of cases in each of the three divisions of the classification :

	No. Patients treated.	Cured.	Improved.	Unimproved.
Tuberculosis of long and flat bones....	71	26 (36%)	25 (35%)	21 (29%)
Tuberculosis of joints.....	141	54 (38%)	53 (37%)	34 (25%)
Tuberculosis of tendon sheaths.....	27	19 (70%)	6 (22%)	2 (7%)
Tuberculosis of peritoneum.....	32	13 (40%)	8 (25%)	19 (35%)
Tuberculosis of testicle.....	21	7 (33%)	10 (48%)	4 (19%)
Tuberculosis of lymphatic glands.....	226	79 (35%)	92 (40%)	55 (25%)
	518			
Tuberculosis of skin (lupus) .....	616	420 (68%)	148 (24%)	48 (8%)”

Drs. P. Ridard and Barret<sup>1</sup> report successful results in treating osteoarthritis and tuberculous osteitis; also they noticed improvement in several cases of arthritis accompanied by fibrous ankylosis. Irradiations, lasting seven minutes, were given with intervals of twelve to fifteen days; by using a thin leaf of aluminium filter no dermatitis was produced.

I treated a number of cases of large areas of tuberculosis of the skin. In Figs. 234 and 235 are shown the ravages of cutaneous tuberculosis in a youth of 21. In the left-hand photograph is the view of the face and neck when the patient first presented himself at the Philadelphia Hospital for treatment. In the right-hand picture are shown the results of X-ray treatment in the disappearance of all the elevations, white areas replacing the former sites of tuberculous deposits.

## B. LEUKÆMIA.

The value of the X-ray treatment of leukæmia is a matter of discussion. Many authorities assert that cases of this disease have been permanently cured by the repeated application of the rays; other investigators, equally distinguished, maintain that Röntgen treatment is a valuable adjunct only to the usual remedial agents employed. At the conclusion of this article, some views on the subject, which are worthy of perusal, are appended.

Fried<sup>2</sup> stated, that in a case of inoperable carcinoma of the mammary gland and in a second case of intra-abdominal sarcoma, treatment by the X-rays showed a great decrease in the number of white corpuscles and an increase in the reds.

Inseen<sup>3</sup> reports two cases of pseudo-leukæmia treated by the X-rays,

<sup>1</sup> Arch. d'Électricité Médicale, February, 1906.

<sup>2</sup> American Medicine, June, 1902.

<sup>3</sup> New York Medical Journal, April 8, 1903.

in which marked improvement was noted. On account of the toxæmia set up in each case, the treatments had to be suspended for a short period. He believes that the rays will prove to be a means of curing a heretofore incurable disease.

Nicholas Senn<sup>1</sup> reports the treatment with X-rays of two patients, far advanced in pseudo-leukæmia. In the first patient, after 34 applications of the X-rays, all the enlarged glands had almost entirely disappeared and the general condition was much improved. When discharged, no glands were palpable; the blood, however, did not show any characteristic changes. The second patient showed universal enlargement of the lymphatic glands. The blood examination revealed a well marked anæmia and a leucocytosis of 208,000, the increase being most marked in the lymphocytes (78.75 per cent.). This patient was also treated with the X-rays, and after fifteen exposures he developed a slight toxæmia; treatment was then discontinued. However, the general condition of the patient was much improved; all palpable glands were diminished in size and the number of leucocytes was reduced to 76,000. The treatment was again renewed, and progressive improvement continued, the patient being discharged practically cured.

Meyer and Eisenreich<sup>2</sup> reported two cases of myeloid leukæmia treated with the Röntgen rays. They differ in several points from others that have been published. The first patient, aged 31, was a machinist by occupation. Blood findings altered completely under the influence of the rays, and a marked leucocytosis followed, with mast-cells predominating. By the end of four months the leucocytes had fallen from 165,000 to 6100, but then rose again to about 22,000, and later to 35,000. The blood findings altered so materially under the influence of the rays that no one would have suspected leukæmia from the blood picture. The spleen returned to normal size in the first case, but remained enlarged in the second case, in which the leukæmia was of longer standing and the symptoms more serious. Since suspension of the treatment, the blood findings have displayed a tendency to return to the leukæmic picture, so that the hope of actually curing leukæmia by this means is not very promising.

Wendel, of Marburg, has collected from the literature 38 cases of leukæmia treated with the X-rays and adds another to the list. He tabulates the details of the various cases and states that more than 90 per cent. were favorably influenced. In two instances no appreciable benefit was observed, and in two, the disease rapidly progressed notwithstanding the treatment.

Dr. Steinwand,<sup>3</sup> of Selma, Cal., reports a case of pseudo-leukæmia

<sup>1</sup> New York Medical Journal, April 18, 1903.

<sup>2</sup> Münchener medicinische Wochenschrift, January 24, 1904.

<sup>3</sup> Journal of the American Medical Association, March 26, 1904.



successfully treated by the X-rays: "The patient, a school-girl, aged 15. Family history: Mother died from heart disease two years ago; father well; three brothers, two of them are well, one has chronic stomach trouble; three sisters, all well. No tuberculous or syphilitic history.

"About five or six years ago the glands on the left side of her neck became enlarged, but were not painful. During the succeeding years they increased slowly but gradually, and there were occasional sharp pains in the splenic region. Two years later the glands along both borders of the sterno-mastoid muscle began to coalesce and rapidly increase in size. The supraclavicular glands also became prominent, and later the axillary glands were involved.

"The patient came for treatment April 1, 1903. She presented all the symptoms above enumerated, with rapidly increasing nervous phenomena and steady loss of weight. All the treatment she had received was ineffective in checking the course of the disease. There had not been any definite diagnosis.

"There were large glandular masses on the left side of the neck, anterior and posterior to the sterno-cleido-mastoid muscles, the larger ones about the size of a hen's egg. They were movable under the skin, but bound down more or less to the deeper structures. The spleen was somewhat enlarged and tender to pressure. Temperature was 100° to 101°. The hæmoglobin index was 70 per cent. The differential leucocyte count was negative. The pulse was 115 to 120. I failed to make a blood count. At no time did I detect the temperature lower than 100° or the pulse-rate less than 102.

"On April 20, I advised the use of the X-rays and gave the first exposure. The neck measured 13½ inches over the most prominent portion. I made one exposure each day, of a duration of fifteen to twenty minutes. After the exposure on the second day the patient complained of feeling much worse. After the third exposure splenic tenderness was greatly increased, so that gentle percussion caused considerable pain.

"April 24th her neck measured 12½ inches and had visibly decreased in size. Two days later it measured 12 inches. The temperature was 103°, the pulse 115.

"On April 30 the neck measured 11¾ inches. The supraclavicular glands were much shrunken and becoming hard, nodular, and more freely movable under the skin. Temperature was 100°, pulse 100.

"May 1 I stopped X-ray treatment, as there was some evidence of dermatitis. On May 5, temperature was 98.4°; pulse 100, this being the first time I found temperature normal in three months' observation.

"May 12. The dermatitis was fully developed and the skin was sloughing in some places."

Until the latter part of July, treatment could not be directed to the local seat of disease, because of the dermatitic area.

"July 24 the glands were still receding, and the neck measured 11 inches. The contour fairly matched that of the opposite side. She stated that she felt in the best of health, and her appearance fully bore out her assertion.

"As treatment progressed, the spleen increased in size. This phenomenon was also noted by Senn, but I have not seen any mention of the distinct rise in temperature after each treatment, encountered in this case. The only explanation that I can offer is that there must have been certain toxic products, liberated through the influence of the X-rays, which were at once taken up by the circulation, causing also the acute exacerbations of ill feeling following each exposure. This condition of elevated temperature and ill feeling lasted from ten to fourteen hours, and was so severe at times I thought of abandoning treatment had it not been for the steady reduction of the size of the glands."

In my own cases, however, I have never encountered this so-called auto-intoxication resulting from irradiations. It would seem that the subject needs much further investigation.

At a meeting of the Chicago Medical Society held January 25, 1905,<sup>1</sup> Drs. Joseph A. Capps and Joseph F. Smith reviewed the advancements made in the treatment of lymphatic leukæmia with the X-rays.

The first case was treated by Dr. Pusey for one month, but without improvement. In 1903 Dr. Nicholas Senn reported a case of leukæmia symptomatically cured. The patient presented the typical symptoms of spleno-myelogenous leukæmia and had been ill for fourteen months. Treatment was begun daily, and was given every other day through the latter part of January and during February, March, April, and May; at the time of Senn's last observation the white count came down to 10,000 and the spleen was almost of normal size. The patient felt perfectly well, but died later with symptoms of toxæmia. Cases of lymphatic leukæmia treated by Senn, Churchill, and Pusey died within seventeen months.

The authors reported three cases of lymphatic leukæmia treated by the X-rays, two of which were of the acute form. One patient died in six days, and the other in ten days. Of the subacute cases there were two. While the X-ray exerted a beneficial effect, it did not control the disease. Better results were obtained in treating chronic cases, of which the authors reported three. They stated that patients with spleno-myelogenous leukæmia should receive X-ray treatment, because they are greatly benefited thereby. They respond more slowly than do patients with chronic lymphatic leukæmia. These patients feel that they are cured, but in the light of cases reported as symptomatically cured, some of which have since died, physicians must not be too sanguine in regard to pronouncing cures.

<sup>1</sup> Journal of the American Medical Association, February 10, 1905.

Arneth<sup>1</sup> made a careful study of the blood findings after exposure to the Röntgen rays, and analyzes all the testimony thus far offered. His final verdict is that the Röntgen rays have an undoubtedly favorable action in leukæmia, but that it is indirect. They do not cure the lesions, but they destroy the parasites which are causing the lesions. The action of the Röntgen rays in leukæmia is like that of quinine in malaria. Both cure the patient by killing off the micro-organisms causing the trouble. This assumption entails the necessity for more thorough and more general exposure to the rays. They should be as extensive and as protracted as possible, to seek out and destroy the causal germ in its remotest lurking-places, not restricting the exposures, as in the past, to the blood-forming organs alone. This conception supplies, for the first time, an etiological treatment for leukæmia and one that is proving more successful than any in the past.

The clinical and histologic findings in leukæmia after Röntgen treatment were observed by Lossen and Morawitz.<sup>2</sup> The patient was a man of 36, previously healthy, with myeloid leukæmia for two or three years before it terminated fatally. Forty Röntgen exposures were made, but did not seem to arrest the progress of the disease after the first transient improvement. The composition of the blood and the blood findings changed under the exposures, finally presenting the picture accompanying aplasia of the blood-forming organs, and the anatomical findings were those of hypoplasia. It was most pronounced in the bone-marrow, but was also unmistakable in the spleen and lymph-glands. It was accompanied by pronounced proliferation of the interstitial tissue. Lossen and Morawitz are inclined to regard the hypoplasia as favored and possibly originated by the three weeks of rather intense Röntgen treatment given in this case. Of 7 leukæmic patients treated by Röntgen exposures, 3 were materially improved, and the others are still under treatment, with the exception of the fatal case mentioned above. In one case of myeloid leukæmia the leucocyte formula became normal, and the elimination of uric acid also returned to normal proportions. This suggests an increased new formation of leucocytes as probable. In the first case with extreme leucopenia the amount of uric acid eliminated remained abnormally high throughout.

While Drs. David L. Edsall and J. K. Pancoast, of Philadelphia, believe that X-ray treatment of leukæmia is unsatisfactory because of secondary results, Musser<sup>3</sup> is of the opinion that the reason for this is that the treatment was undertaken in old cases in which secondary changes had occurred before the use of the X-rays, which only served to stimulate the progress of such changes. In one case of his own, treated

<sup>1</sup> Münch. med. Woch., August 22, 1905.

<sup>2</sup> Deutsches Archiv f. klinische Medizin, Leipsic.

<sup>3</sup> New York Medical Journal, April 7, 1906.



by the X-rays, there had been an entire disappearance of the leukæmia and the patient had been restored to a normal condition generally. The leucocytes had been reduced from 6000 to 4000, and he believed that a cure had been effected. At the same time, he thought it would be necessary to resort to the X-rays from time to time in order to prevent a recurrence such as had taken place in another case which he had treated.

#### IV. Miscellaneous Affections.

##### A. TRACHOMA.

My technic in treating cases of trachoma consists in covering the Crookes tube with a dark cloth, excluding all light from the room, because of the excessive photophobia. With adhesive plaster I attach the everted eyelids to the skin, and expose the surface of the eye; thus preventing burning the fingers of nurse or assistant. I cover the face with a leaden sheet, and treat one eye at a time, through an aperture in the lead. Rapidity of action is obtained by getting the patient to keep the eye open while under treatment. There is less danger of burn to the cornea than there is to the skin of the eyelid, but, should a slight corneal haziness result, it quickly disappears, and the corneal scar will be absorbed. I had two acute and two chronic cases of trachoma at the Philadelphia Hospital. The acute cases had severe photophobia and lacrymation, which disappeared after four or five exposures.

Sydney Stephenson and David Walsh<sup>1</sup> report the results of treatment of trachoma or granular lids by the X-rays and by brush discharges obtained from a D'Arsonval high-frequency apparatus. The writers treated a single eye in four cases of severe bilateral trachoma in children. Two eyes were cured, that is, the granulations and conjunctival hypertrophy disappeared, and have not returned after a period of several months. The remaining two eyes were greatly benefited and are recovering. The cures were effected by 17 exposures in one case and but 6 in the other. The average time was ten minutes. The good effects were found to be equally marked with closed as with everted eyelids. Twenty-two applications of a mild high-frequency brush, using a vulcanite electrode connected with a D'Arsonval apparatus, cured a severe case of trachoma in another patient.

Radiotherapy in trachoma presents advantages over the ordinary treatment by escharotics. It is more rapid and is painless. The fact that equally good results were obtained with an active focus tube, and also by a high-frequency brush discharge, suggests that the curative agency may be identical in both instances.

<sup>1</sup> Lancet, January 24 1903.

At a meeting of the Philadelphia County Medical Society, November 23, 1904,<sup>1</sup> Drs. W. S. Newcomet and J. P. Krall presented a girl of 18, who had been subjected to all the operations for the cure of trachoma, without success. She was treated with the X-rays from July, 1903, until January 1, 1904. The inflammatory reaction was so intense that it was thought better to abandon the treatment. Later, however, it was found that she could count fingers at close range. The cornea was entirely clear, and only with special illumination could there be seen fine blood-vessels. The eye not treated with the X-rays showed all the symptoms that the treated eye formerly exhibited. The condition of the patient had been present since infancy, and she had been unable to see across the room. Treatment was given every other day for five minutes for about six weeks, when a burn developed and treatment was withheld. Dr. Newcomet believed the result to be due to the accidental burn produced in the course of treatment.

Ruggero Pardo<sup>2</sup> describes two cases of trachoma of long standing, rebellious to treatment. Six exposures, with a total of 44 minutes in one case and of 47 in the other, caused so marked an improvement that a permanent cure is anticipated. The tube had a spark length of 2.5 to 2.7 inches (6.5 to 7 cm.), the distance varied from 12 to 15 inches (30 to 45 cm.), the applications were from 4 to 10 minutes at a time, and only one eye was treated; the eyeball was protected by a sheet of lead at some of the séances.

Geyser<sup>3</sup> maintains that a few exposures, six to eight, will suffice to bring about a perfect cure. An important consideration is to cause absorption and stimulate normal nutritional processes; nothing seems to answer the purpose any better than the direct contact of the tissues with a high-frequency vacuum tube, generated by a static machine or X-ray coil. Complete details of technic are given in the article.

H. N. Bishop<sup>4</sup> gives the results of electrical treatment of trachoma at the Middlesex Hospital. Cases had been treated with well-equipped apparatus, with rays, high-frequency currents, and radium. With regard to the X-rays he explains that there were two sets of rays emanating from the tube, (1) the X-rays proper, (2) the overflow rays that cause the severe burning of the skin which sometimes occurred. The former of these rays were used. Four cases of trachoma were treated in this manner. Two were young women. In one, fifty applications were made in five months. The right eye showed changes that might reasonably have been produced in this time without treatment, while the left, which was at first unaffected, steadily got bad. The disease subsequently

<sup>1</sup> Journal of the American Medical Association, January 14, 1905.

<sup>2</sup> Gazzetta degli Ospedali, Milan, last indexed xiii., p. 1193, April 10, 1904.

<sup>3</sup> Journal of Advanced Therapeutics, May, 1904.

<sup>4</sup> British Medical Journal, August 26, 1905.



FIG. 234.—Tuberculosis of the skin.



FIG. 235.—The same after irradiation.





FIG. 236.



FIG. 237.



FIG. 238.

Groups of patients that I irradiated for epilepsy at the Philadelphia Hospital. Upper two rows (Figs. 236 and 237) show alopecia produced by X-rays during three months of treatment for epilepsy. No. 8 on the second row was not thus affected. Fig. 238, taken six months later, shows the regrowth of the hair. No. 7 was previously bald, but upon application of the rays the growth of hair appeared.

cleared up in the usual manner with bluestone. None of the three other cases did any better. The seven cases treated with high-frequency currents did not improve at all.

Vassiutinsky<sup>1</sup> asserts that the rays diminished the infiltration in trachoma, caused the disappearance of the granulations and of the pannus, and produced a pronounced improvement in the subjective signs of the malady. As a rule, however, trachomatous granulations disappeared but slowly under the influence of the Röntgen therapy. The rays proved to be harmless in treating the eyes, and no evil effects were noted in any case, nor was pain experienced by the patients. The author thinks that the rays are of service in cases in which ordinary methods of treatment fail.

I treated a case of chronic conjunctivitis of both eyes referred to me by Dr. T. B. Schneideman. The patient had been a sufferer for fifteen years. I exposed the eyes, once weekly, to the action of the rays. The treatment was not continuous, as I feared a constant and frequent application of the rays. I began treatment with a one-minute exposure twice weekly, tube fifteen inches from the part. Within two years sixty applications were made. The first fifteen treatments were of one minute duration. I then increased treatments gradually up to five minutes. The conjunctivitis is practically cured, and the blood-vessels of the part have become small and shrunken.

#### B. KELOID.

Dr. William H. Harsha<sup>2</sup> reports the case of a young man, eighteen years of age, who had a small growth behind the right ear for ten years that microscopically proved to be a keloid. It was excised, but in three or four months the tumor was as large as ever. X-ray treatments were then begun and were given at intervals of two or three days, but were not kept up regularly. He had not frequent treatments by the X-rays in the last six months. The growth now showed not more than one-sixth of its size when the treatment was begun and it was still getting smaller.

Dr. A. J. Ochsner asserts that the treatment of keloid by means of the X-rays is worthy of attention. In several cases the improvement was very marked after operation by the subsequent X-ray treatment. He believes that before removing any keloid one should treat it thoroughly with the X-rays.

Dr. H. R. Varney<sup>3</sup> reports a case of keloid of the foot, caused by passage of a rifle-ball. Eight treatments were given; complete disappearance of the keloid with development of normally appearing scar tissue

<sup>1</sup> Roussky Vratch, January 8, 1905.

<sup>2</sup> Chicago Surgical Society, December 7, 1903.

<sup>3</sup> The International Journal of Surgery, October, 1903.

resulted. The patient had also a keloid the diameter of a silver dollar at the site of vaccination.

Dr. G. P. Edwards<sup>1</sup> reports three cases of keloid cured with the X-rays.

Morris and Dore<sup>2</sup> report that they have treated a few cases of keloid with the X-rays, in some of which there had been a decided increase in the growth. Pain was in all cases completely relieved.

Dr. Henry K. Pancoast<sup>3</sup> reported two cases of keloid treated by the rays. In one case there were multiple keloids following a burn. The other patient had a large keloid involving the ear, neck, and angle of the jaw. Both patients were colored. In the first case six treatments were given, and in the second forty-three treatments. The results were negative, probably because the treatments were not pushed.

Drs. Fordyce,<sup>4</sup> Fox,<sup>5</sup> and H. R. Barney<sup>6</sup> report favorable results.

Dr. O. S. Barnum<sup>7</sup> uses an abundance of rays emanating from a tube of high resistance and excited by a large coil. He believes that it is better to have the tube too high than too low. The tube's distance should be fifteen to twenty inches, depending on the thickness of the tumor. The thicker the tumor, the higher the tube, the greater the distance and the longer the exposure. He usually exposes the growth for from fifteen to twenty-five minutes on alternate days for ten days, and then stops treatment for ten days, repeating the procedure until the tumor has disappeared. He has had excellent results in the treatment of keloids by this method.

Drs. Boggs, Pancoast, and others favor preliminary excision of the tumor, whenever this is possible, following this with Röntgen treatment. The tumors disappear more rapidly and are not so liable to recur.

### C. EXOPHTHALMIC GOITRE.

Dr. Charles H. Mayo,<sup>8</sup> in a paper entitled "Thyroidectomy for Exophthalmic Goitre," says: "It has been our fortune, or misfortune from its difficulties, to operate on several cases of cervical adenitis which had been exposed for many times to the X-rays. It was noted that the lymph system was greatly sclerosed. As this was in line with the reported action of the X-rays upon glandular activity, we applied this treatment to ten cases of very marked exophthalmic goitre during the

<sup>1</sup> The International Journal of Surgery, October, 1903.

<sup>2</sup> British Medical Journal, June 16, 1903.

<sup>3</sup> Proceedings of the Philadelphia County Medical Society, November 30, 1903.

<sup>4</sup> Journal of Cutaneous Diseases, April, 1904, p. 187.

<sup>5</sup> Ibid., July, 1903, p. 323.

<sup>6</sup> Journal of the American Med. Association, June 6, 1903.

<sup>7</sup> Transactions of the American Röntgen Ray Society, 1906.

<sup>8</sup> Medical Record, November 5, 1904.



past year, to first reduce glandular activity, and second, reduce absorption by its possible effect upon the lymphatics. While I would not as yet say that any of these cases are cured, they have certainly been markedly benefited; first, in the general nervousness; second, in tremor of the muscles; third, in tachycardia; and last, in the exophthalmos. The benefit is sufficient to give this method a place in the treatment of Graves' disease, or at least make it a preparatory treatment to a prospective surgical method at a later period. . . .

"Our rules, concerning the cases of Graves' disease which come to us for operation, are to operate, if their condition is fair, but if the pulse is from 130 to 160, or if it suddenly fluctuates in tension and rapidity, if there is anæmia, with swelling of the feet, the patients are placed upon the belladonna treatment for some days. The more severe types are also given X-ray exposures in addition, which are continued from two to six weeks."

Görl<sup>1</sup> has tried radiotherapy in goitre with what he considers very encouraging results. Seven cases were treated, and in all there was marked diminution in the size of the growth, as well as improvement in the other symptoms. The author believes that it is primarily the parenchyma cells that are affected by the rays, and not the blood-vessels, as the diminution in size of the gland begins so promptly and takes place so uniformly. Medium soft or soft tubes were employed, and at a comparatively short distance from the skin. Care is necessary to prevent burns; in one case the author found the patient's skin was unusually sensitive to the rays, and he suggests that this condition may be one of the symptoms of the disease.

G. E. Pfahler<sup>2</sup> speaks of 31 cases that he collected, with an improvement in 28 of them. Stegman<sup>3</sup> speaks most favorably of X-ray treatment in 35 of his goitrous patients.

Widerman<sup>4</sup> has noted improvement in some of the symptoms in his five cases.

Dock<sup>5</sup> treated 32 patients with exophthalmic goitre, and he believes that X-ray treatment is only an adjunct to other therapeutic measures.

Pfeiffer<sup>6</sup> describes his experiences with Röntgen treatment of goitre at von Bruns' clinic at Tübingen. The particulars of 51 cases are given and the histological findings in 8, with the results of experimental research. The general conclusion is to the effect, that Röntgen treatment of goitre is ineffectual as a rule and should not supplant the better-trying methods.

<sup>1</sup> Münch. med. Wochenschr., vol. lii., No. 20.

<sup>2</sup> Therapeutic Gazette, March 15, 1906.

<sup>3</sup> La Tribune Médicale, January 27, 1906.

<sup>4</sup> Ibid.

<sup>5</sup> American Medicine, February 24, 1906.

<sup>6</sup> Beiträge R. klin. Chirurg. von Bruns, Tübingen, p. 1149.

Dr. Charles Lester Leonard<sup>1</sup> noticed marked improvement in four cases of goitre. One of the patients has had no recurrence for a period of three years.

Dr. T. V. Crandall had a patient, aged 22, suffering with a unilateral goitre. I irradiated the tumor twenty times within sixty days, and the goitre became markedly decreased in size. The previous nervous disturbances at once abated. I believe the action of the rays in these cases is quite analogous to its action in tuberculous adenitis and other glandular affections.

#### D. HYPERTROPHIED PROSTATE.

Carabelli and Luraschi<sup>2</sup> report two cases of hypertrophied prostate treated by X-rays after one year's observation. They were the first cases properly treated by this method. The patients were respectively sixty and sixty-five years of age. They were placed on a sloping table, the surrounding parts carefully protected, and the Röntgen rays applied to the perineum, with the tube from 20 to 25 cm. from the skin. Carabelli did not think it necessary to introduce a tube into the rectum, as the atrophying action of the Röntgen rays on deep-lying glands, like the ovary, spleen, and lymphatics, had been amply established. It is evident, also, that the action of the rays on the prostate is more pronounced when the hypertrophy is in the first stage. The relief of the pain was marked from the very first. The rays were applied fifteen times, at first two or three times per week and then once a fortnight. The sensory symptoms vanished and urination became very much easier.

In the second case the prostate was much enlarged and hard, and there were about 200 gm. of residual urine and evidences of chronic catarrh of the bladder. After six applications of the X-rays, the urine became clearer, the pain subsided, urination was much easier, and the residual urine was only 40 gm. After the tenth application, there were only 10 c.c. of residual urine, and the patient was dismissed as practically cured. The treatments were from three to seven minutes in the first case and ten minutes in the second; the current  $1\frac{1}{2}$  amperes and 100 volts. After one year the results are permanent.

In view of the fact that hypertrophied prostate in most instances is due to a glandular proliferation, and therefore contains epithelial elements very susceptible to the Röntgen rays, Dr. Moskowicz, of the Rudolph Hospital,<sup>3</sup> has treated a number of cases of this kind by radiation through the rectum. After a few treatments the patients were able to urinate spontaneously, and the improvement has persisted. Large

<sup>1</sup> New York Medical Journal, April 21, 1906.

<sup>2</sup> Gazzetta degli Ospedali Milano and abstracted from The Jour. of the Am. Med. Asso., Sept. 2, 1905.

<sup>3</sup> Semaine Médicale, April 5, 1905.

indurated prostates became smaller and softer. It is the intention of Dr. Moskowicz to try radium in other cases, as being more suitable and probably more efficient.

#### E. ANALGESIC ACTION OF THE RAYS.

*Neuralgia.*—It would seem almost a certainty that the X-rays possess an analgesic action. In carcinoma the pain is frequently alleviated after the first few exposures. The analgesic action is less potent in deep-seated cancers than in superficial ones. Freund, in 1899, reported that Grunmach had most excellent results from the use of the rays in neuralgia and articular rheumatism. Gocht found marked temporary relief in a case of obstinate trigeminal neuralgia. Dr. William M. Sweet,<sup>1</sup> of Philadelphia, believes that X-rays exert a peculiar action on the nerve tissue, as the skin after intense irradiation becomes quite anæsthetic. In connection with this interesting subject are appended the views of Dr. Charles Lester Leonard, of Philadelphia,<sup>2</sup> who reports eight cases, six of neuralgia, one of neuritis, and one of scar tissue of the brain following the removal of a cyst from the motor area five years previously, in which the Röntgen rays formed the principal treatment.

All of the six cases of neuralgia were due to impaired metabolism of the nerve tissue. The first was infra- and supraorbital neuralgia following an attack of influenza; the pain was relieved by the first treatment of three minutes and cured permanently by four more such treatments. The second was a severe neuralgia of both inferior and superior dental nerves, which had lasted seven months and was accompanied by loosening of the teeth; three five-minute applications upon each side of the face every other day relieved the pain entirely; the teeth resumed their proper place, and at the end of eight treatments the patient was entirely well. He has remained so for the past two years.

The third was a case of migraine which had existed for ten years, resisting various kinds of treatment. The first application lessened the intensity of pain, and at the end of the course of treatment (number of applications not stated) she was entirely cured.

The fourth case was trigeminal neuralgia and was much relieved, but the patient discontinued treatment after four weeks and has not since been heard from.

The fifth was a case of brachial neuralgia; this patient also discontinued treatment prematurely.

The sixth was a case of severe tic douloureux with crises almost every five minutes. The first application relieved the pain, but the patient left town after four treatments, promising to report if he had any further attacks; he has not since reported.

<sup>1</sup> American Medicine, Dec. 13, 1902.

<sup>2</sup> Ibid., July 8, 1905.



The case of neuritis occurred in the facial nerve, and evidence of degeneration was shown by areas of local anæsthesia over its entire distribution, the point of most intense pain being over the mastoid region and the posterior surface of the ear in the distribution of the posterior auricular nerve. This patient was greatly relieved, but not entirely cured, possibly because the treatments were not applied with sufficient regularity.

The patient in whom it was attempted to produce absorption of scar tissue had complete paresis of the right arm, with glossy skin on the fingers and absence of wrinkles; the arm could not be raised voluntarily. Right leg was also somewhat lame. Slight epileptiform attacks which had occurred recently were attributed to a recent blow upon the occiput. As a result of the X-ray applications the epileptiform attacks became less severe and less frequent, and the patient gradually gained control of the arm and hand, so that he could raise the hand to his head and mouth and could grasp objects of moderate size. There was also decided improvement in his gait and speech. He received 12 applications in 6 weeks, the rays being applied through the trephine-opening in the skull. As the bromides were continued in increasing doses with the Röntgen applications, it is considered possible that the results cannot be attributed exclusively to the rays.

Leonard appears to believe that successful treatment of such cases is very largely dependent upon a proper technic.

Haret<sup>1</sup> treated successfully with X-rays an obstinate case of trigeminal neuralgia after all other methods had proved unavailing. The painful region was irradiated through the mouth, the neighboring parts being protected by a tube of lead glass. The X-rays were directed on the alveolar border in the region of the first and second molar teeth. A dose of four Holz knecht units was given daily, using rays corresponding to number seven or eight on Benoist's scale. After the first and second sésances there was no noticeable change. After the third irradiation the patient asserted that there was some diminution of the pain. There was slight reaction of the skin on the border of the upper lip, which had been imperfectly shielded from the rays. After the fourth sésance there was a complete cessation of all pain. Since then the patient has remained free from any recurrence of the affection.

For four years Faber's<sup>2</sup> patient had suffered from trigeminal neuralgia, with two intervals of a few month's freedom from pain after operation. As the neuralgia recurred with increased intensity and frequency, ten Röntgen exposures of ten minutes each were applied to the upper half of the face within sixteen days. Improvement was evident at once and the patient was soon entirely free from pain. There has been no recurrence during the few months since.

<sup>1</sup> Archives of the Röntgen Ray, May, 1906.

<sup>2</sup> Hospitalstidende-Copenhagen, last indexed page 813.

Dr. E. B. Bondurant<sup>1</sup> reports that one application of the X-rays apparently cured facial and intercostal neuralgia. Dr. S. W. Allen reports several cases which show that neuralgic pains ceased even when the X-rays were used for making the diagnosis. I have noticed that many cases of neuralgia were temporarily cured when the X-rays were used for diagnosing dental conditions.

#### F. EPILEPSY.

Four years ago I examined a boy's skull for depressed bone, the lad being a sufferer from epilepsy. His physician informed me that since his X-ray examination there was a complete absence of epileptic seizures; this suggested the treatment of epileptic cases by the X-rays.

Two years ago, through the courtesy of Dr. W. W. Hawke, Superintendent of the Insane Department of the Philadelphia Hospital, twelve patients were selected, the youngest being six and the oldest sixty, the attacks varying from a very mild type to a severe epileptic seizure. (Figs. 236, 237.)

X-ray treatments began in February, March, and April, 1904; treatment three times a week, exposures five minutes, distance of the anode 8-10 inches (20 to 25 cm.). Various parts of the skull were exposed. After two months' treatment alopecia was produced.

The results and improvements from the X-ray treatment were quite satisfactory, as will be noticed from the lower group of photographs. (Fig. 238.)

The following table exhibits the number of attacks in 1903 and 1904, showing the improvement due to the rays:

CASES.	RESULTS.
I. Number of attacks in 1903 were 68. Number of attacks in 1904 were 41.	Decrease of 27.
II. Number of attacks in 1903 were 845. Number of attacks in 1904 were 412. No attacks during October, November, December.	Decrease of 433.
III. Number of attacks in 1903 were 59. Number of attacks in 1904 were 14.	Decrease of 45. Attacks ceased two months after treatment, but patient died on May 7, 1904.
IV. Number of attacks in 1903 were 85. Number of attacks in 1904 were 80.	Decrease of 5. Patient died five months after the beginning of the treatment.
V. Number of attacks in 1903 were 144. Number of attacks in 1904 were 120.	Decrease of 24. No attacks during October, November, December.

<sup>1</sup> New York Med. Jour., August, 1902, vol. lxxvi. pp. 194-196.

- VI. Number of attacks in 1903 were 209.  
 Number of attacks in 1904 were 191. Decrease of 18.  
 No attacks during October, November, December.
- VII. Number of attacks in 1903 were 69.  
 Number of attacks in 1904 were 4 during the same months.
- VIII. Number of attacks in 1900 were 6.  
 Since then no attacks.
- IX. Number of attacks in 1903 were 148.  
 Number of attacks in 1904 were 164. An increase of 16.  
 Number of attacks increased during the treatments, but during October,  
 November, December, there were no attacks.
- X. Number of attacks in 1903 were 61.  
 Number of attacks in 1904 were 77. Increase of 16.  
 Increased during the treatment.

These results of X-ray treatment of epileptics, I believe, are encouraging when we notice the decrease in the number, duration, and severity of the attacks. I cannot think that any harm can be done, except the alopecia that may be produced.

The sudden death of two young patients during and immediately after the treatment was not the direct result of the X-ray treatment, although the autopsy showed congestion of the brain, which might have been due to some other cause.

Horace Manders<sup>1</sup> states that it is only two or three years since Branth conceived the idea of using the X-rays for the relief of epilepsy, on the theory that these rays stimulate protoplasm into greater vital activity. He gave three treatments a week, beginning with five minutes' exposure at 15 inches distance, and increased to ten minutes' exposure at 10 inches distance. A different part of the skull was exposed at each sitting. A hard or high-vacuum tube, backing up a spark-gap of 5 to 8 inches, was used. One objection to this treatment is the alopecia which follows it, but the hair will return in a stronger growth than before. It may also be desirable to continue the use of the bromide with the X-rays. This treatment is usually followed by a gain in weight, by improvement in enunciation (if that were faulty), and by lighter seizures of shorter duration and at longer intervals. This treatment is not available if degenerative processes of the brain have begun.

Dr. J. H. Branth<sup>2</sup> gives three treatments a week, beginning with 5-minute exposures at 15 inches distance, and by degrees increases to 10 minutes at 10 inches. A different part of the skull was exposed at each sitting, and a tube of high penetration used. The hair drops off usually near the parts exposed, but returns later in stronger growth. In some

<sup>1</sup> Archives of the Röntgen Ray, April, 1905.

<sup>2</sup> New York Medical Journal, June 11, 1904.



cases the bromides can be dispensed with ; in others, small doses prove beneficial. In young subjects a gain of weight soon results, and a marked improvement in the mental faculties takes place. The impediment in speech, which occurs in severe cases of long standing, has been removed by raying, and the attacks, which numbered from 6 to 10 a day, were reduced to one every 2 or 3 weeks.

It is to be hoped that these results will be confirmed by others. I recall a case where I took two radiographs of the head, with a view of locating the cause of the seizures. The patient had no attacks for over two months following the exposures.

## CHAPTER VI

### RADIUM AND OTHER RADIO-ACTIVE SUBSTANCES.

THE remarkable chemical body radium, discovered some years ago by Prof. and Madame Curie, belongs to the alkaline group of elements. Madame Curie makes the atomic weight 225. We know that barium has an atomic weight of 136.4 and thorium 230.8; thus, according to the periodic law of atomic weights, first outlined by Mendeleëff, radium would stand between the two just mentioned. Demarçay first demonstrated that radium was an element, being characterized by a spark spectrum of 14 or 15 lines.

#### OCCURRENCE.

Radium is a very rare element and has for its source ordinary pitch-blende, occasionally spoken of as uranium. An abundance of this mineral is found in various parts of the world, chiefly in Cornwall, Colorado, Nevada, Saxony, Bohemia, and Thibet.

Pitch-blende is a mineral of a "pitchy" appearance; chemically, it consists of the double oxides of uranium, the oxides of lead and zinc, in combination with more or less rare and peculiar metallic bodies in smaller quantities. Uranium, a commonly used body, the salts of which are of beautiful tints on the border of yellow, has been for years extracted from pitch-blende. What was formerly cast off as the useless substance of pitch-blende is to-day saved for the purpose of extracting therefrom radium, helium, etc.

#### CHEMICAL AND PHOTOGRAPHIC EFFECTS.

Professor Henri Becquerel, a noted French physicist and chemist, learned that the compound potassio-sulphate of uranium was endowed with properties similar to those manifested by zinc sulphide and other bodies. He discovered that when uranium or any of its salts was exposed to helious radiations, they became endowed with the faculty of absorbing the rays, which in turn could be induced to act upon the film of a sensitive photographic plate. That this phenomenon was displayed by metallic uranium caused him to believe that the same result might take place if he used the ore from which it was derived primarily. Following this line of reasoning, he employed ordinary ore (pitch-blende), desiring to influence a sensitive plate by exposing the complex ore to the rays of the sun. The sun was obscured by clouds; so he removed the ore, also a key (that he desired to image), and the sensitive plate to a

closet, intending to conduct the experiment at some future day. Fortunately for science, he forgot the experiment for several days, and, upon examining the plate after developing, he observed that the image of the key had already been imprinted into the sensitive coating of the pitch-blende. Thus, accidentally, he discovered that uranium ore, the pure metal and also its salts, would cast an image on a plate, and that a previous exposure to sunlight was not essential to the evolution of these dark, invisible rays. Even though a uranium salt be crystallized out of its solution in the dark, and allowed to remain there, it still possesses the property of emitting rays which affect ordinary photographic plates.

Photographic paper becomes brittle after prolonged exposure. Ozone is formed in the air about radium. The rays are not affected by the extremes of temperature.

Like Elster and Geitel, who observed that certain substances which had been exposed to light emitted radiations capable of discharging negatively electrified bodies, Becquerel observed the same quality in the radiations that bear his name.

Sir William Crookes, soon after the discovery was made public, subjected the salts of uranium to a close examination, and he theorized that these radiations were not due to the uranium itself, but to contained impurities in the salt. He crystallized repeatedly the substances, exercising care to separate the crystals into two portions,—on one side he placed those crystals which formed with greater ease, and on the other those which formed slowly. He observed that one set of crystals possessed the power of readily emitting rays,—*i.e.*, they were said to be radio-active,—while the other lot of crystals were devoid of such phenomenal activity.

At the outset Professor and Madame Curie reasoned, and correctly so, that the largest percentage of the radio-active substance, as yet unknown, was found in the ore (pitch-blende) and not in uranium. They undertook the task of extracting the unknown body from the ore, and they discovered that they had now to deal with two distinctly different bodies, the one substance was that which gave off the Becquerel rays, and the other, since those days, has been termed radium, actinium, and polonium. Radium is present in pitch-blende in larger quantities than any of the other radio-active substances.

After the oxides of uranium have been separated from the ore, the residue remaining behind constitutes little more than three-quarters of its weight. This residue contains all the other metals entering into its complex construction, and from these the newer radio-active substances have to be separated, requiring severest attention. Thorium, one of the radio-active elements, extracted from the refuse ore, is not new; having been known by chemists for years. Polonium is contained in the ore in only the minutest quantities. Prof. Markwald was able to extract only 15/100 of a grain of this element from two tons of refuse ore, from which



uranium oxides had been extracted. It seems to be somewhat related to bismuth. Radium usually accompanies the barium obtained from pitchblende; it resembles it in its reactions, and is separated from barium by the differences of the solubility of the chlorides in water or alcohol containing hydrochloric acid. Radium, in the metallic or pure state, has not up to the present time been isolated. It could, however, be isolated with practically no difficulty whatever, according to the opinion of Prof. Curie, by carefully treating the chloride part of the salt with sodium or potassium, forming a chloride salt of either one or both of the latter substances.

#### PHYSICAL PROPERTIES OF RADIUM.

Radium appears like ordinary table salt, with a slightly yellowish tinge. It is weighty and non-deliquescent. It continuously emits a feeble light, which is only recognizable in a darkened room. All the bodies coming in combination (or otherwise) with radium have imparted to them radiations, which are in turn given off. Zinc-blende is especially able to take up these radiations. Radium also constantly gives off heat rays, so that the temperature is always  $1.5^{\circ}$  C. above that of surrounding objects. The view that the ray and heat emanations from a radium salt do not cause a decrease or loss on the part of the salt, is incorrect, the opposite being the case; although we must bear in mind that this loss is very minute.

*Penetration.* — These rays, like the Röntgen emanations, traverse wood and the lighter metals. By placing an aluminium disk on a black paper envelope, covering this with a card, over which are sprinkled crystals of the double sulphate of potassium and uranium that had never been exposed to light, Becquerel was able to obtain a radiograph.

*Fluorescence and Luminosity.* — This is well illustrated by the spintharoscope of Crookes. This consists of a brass tube, having at one end a fluorescent screen and in front of this a little movable arrow. On the under surface of the tip of the arrow, that is just opposite the screen, is a minute particle of radium. At the opposite end of the tube is an adjustable lens. Upon going into a dark room and adjusting the lens to suit the eye, one can see minute particles of light flying off from the screen in every direction, and dancing around at a rapid rate, suggesting a shower of shooting stars. Slight phosphorescence is also produced by radium.

Greef discusses the fact that the rays of radium are visible to the naked eye in the dark. It is not a phosphorescence, as radium maintains this property indefinitely when kept exclusively in the dark without exposure to any light. It induces fluorescence in other objects, and also emits the radium rays proper.

## THEORETICAL CONSIDERATIONS : CLASSIFICATION OF THE RAYS.

What are the emanations (radiations) from radio-active bodies? Like the problem with the Röntgen rays, the very same state of affairs exists, and is yet to be solved in so far as radium and associated radio-active bodies are concerned. A number of authorities are of the opinion that the radiations are minute particles given off, and not the undulations in the surrounding medium (ether).

Crookes speaks of three kinds of radiations: Similar or identical with the cathodic emanations, free electrodes, or matter in the ultra-gaseous existence. Distinct atoms, electrified positively, the air being rendered a conducting medium, and affecting photographic plates. Rays of a very high degree of penetration accompanying the others; Crookes believing them to be identified with the X-rays.

Taking the first group, we may state that the rays are strongly deviated in a magnetic field, the second rather slightly, and the third not at all. They all produce effects on photographic plates, and excite phosphorescent bodies, though all with variable differences. The former and the latter affect strongly platino-barium cyanide; the second have no such effect.

Some speak of three kinds of radio-activity: *alpha*, *beta*, and *gamma*. The alpha rays are easily absorbed and carry a positive electrification; the beta rays easily penetrate solids, and carry a negative charge; and the gamma rays have a very intense penetrative power, but carry no charge. Some state that the gamma and the Röntgen rays are identical, though Strutt, of Cambridge, is of the opinion that there is a vast difference. Crookes maintains that they are actual emanations,—the projection of minute particles from the radio-active body into adjacent space.

Rutherford asserts that if the radiant particles were ejected with slightly less velocity, they would neither ionize the air, affect a photographic plate, nor cause fluorescence; in truth, there would be absolutely no effect capable of detection by our apparatus.

## BIOLOGICAL EFFECTS.

*Bactericidal Action.*—Crookes exhibited a number of plate cultures and photographs illustrative of the bactericidal properties of the emanations from radium. Various cultures of bacteria were exposed to the action of ten milligrammes of bromide of radium, through a mica screen, at a distance of one inch from the surface of the plate. After having been subjected to the action of the radium emanations, the plates were incubated for 24, 48, or more hours. In every case it was found that the microbes were killed where they had been exposed to radium, so that on incubation, a bare space, free from bacterial growths, was left on the plate opposite the point where the radium had been placed. Among the bacteria experimented upon were the bacillus coli communis, the bacillus prodigiosus, etc.

*The Influence of Radium on Agglutination.* — P. P. Jagn<sup>1</sup> tested the effect of radium on the specific properties of blood serum in typhoid fever. It was found that after an exposure of the typhoid blood serum to radium bromide, lasting 2 or 3 days, the serum completely lost its agglutinating properties. An exposure of shorter duration does not destroy the agglutinating power, though the latter undergoes a considerable reduction. These phenomena the author is inclined to attribute to the so-called "beta rays."

Frederick Soddy<sup>2</sup> states that five minutes' application of radium is equivalent to ten years' application of thorium, although both instantaneously produce radio-active emanations of gases in infinitesimal quantities. He believes it possible to inhale the emanations of both these substances in the treatment of pulmonary tuberculosis. The maximum dose of radium solution should be the gaseous contents of a bubble; a few bubbles every 24 hours.

*Physiological Action.*—Heineke<sup>3</sup> believes that the action of radium rays is approximately the same as that of the Röntgen rays. Lymphoid tissue is affected in the same way, but not to the same extent as with the Röntgen rays, unless the radium is brought into close contact, when a brief exposure will astonishingly induce extensive changes in the lymphoid tissue, apparent in a few hours.

*Effects on the Nervous System.*—The effects on the nervous system are interesting and have been chiefly studied in young mice. London found that mice exposed to a strong preparation of radium were killed. There was first redness of the ears, then blinking of the eyelids, then drowsiness, slowness of movement and feeble response to stimuli. This was followed by paralysis, then coma, and finally death. The symptoms developed about the third day of exposure, and the animals died on the fourth or fifth day. Along with these nervous symptoms were well marked effects on the skin. The hair and epidermis were loosened and the subcutaneous tissue was greatly congested.

*Effects on the Eye.*—Radium produces luminous effects on the retina even when the eyes are closed. This is due either to fluorescence of the tissues of the eye, or to direct effect on the optic nerves, probably the former. This effect has been taken advantage of by Javal,<sup>4</sup> London, and others, in experimenting on the blind with radium. In his experiments Javal found, in two cases of blindness in which there still remained a slight perception of light, that the patients perceived a light sensation when radium was held before the eyes. In two other cases of blindness, one due to optic atrophy, and the other to glaucoma, both patients being absolutely blind, there was no perception of light from exposure to

<sup>1</sup> Roussky Vratch, December 6, 1903.

<sup>2</sup> Nature, vol. 78, July 25, 1904, p. 266.

<sup>3</sup> Münchener med. Wochenschrift, vol. li., No. 31, 1904.

<sup>4</sup> Physikal. Zeitschr., 1900, i. p. 476.



radium. London's results are to the same effect. Blind patients who still retained a slight perception of light were cognizant of a visual sensation when radium was applied to their eyes. In those totally blind the results were negative.

#### RADIUM AND THORIUM AS THERAPEUTIC AGENTS.

The attention of the medical world is at present directed to the therapeutic experiments with radium, and so far the results lead us to hope that it will prove of value in the treatment of certain skin diseases and malignant conditions. It is still too soon to pronounce authoritatively upon the permanency of the cure in malignant cases. Already many instances are recorded in which the use of radium has effected complete disappearance of carcinomatous growths, especially the epitheliomata.

Radium does not give so good a differentiation of the tissues as can be obtained by the X-rays, it is of little value in taking radiographs or in making examinations with the fluorescent screen; but on the other hand, radium is far more convenient; it can be easily transported, and can be applied in positions difficult of access with the X-rays, and its action can be readily controlled. It is not so convenient as the X-rays when large surfaces require treatment, but this objection may be overcome by the fact that the emanations from radium salts which will pass through the air, but not through glass, are taken up by rubber and other articles. The absorbed rays are given off slowly from the articles, and apparently have the same effect as those directly derived from the radium salts. Williams<sup>1</sup> remarks that his clinical results with the *beta* rays have been very good, and he is now trying the effect of the *gamma* rays upon deep-seated growths.

The gamma rays are the fewest in number, but are deeply penetrating; the beta rays are more numerous, but act very superficially, and are probably instrumental in causing the burns that have been recorded. The action of the gamma rays alone can be obtained by interposing an aluminium screen, which intercepts the beta rays, but allows the gamma rays to pass through, if the screen be not too thick.

*Diseases of the Skin.*—Scholtz<sup>2</sup> has been testing 25 mg. of radium bromide in the treatment of various skin affections and in tumors, and in conducting experiments on animals. The treatment proved particularly effective in lupus and superficial cancer. The results indicate that radium rays produce effects closely similar to those of the X-rays. The radium can easily be introduced into the mouth, nose, throat, and vagina.

F. Williams<sup>3</sup> bases his conclusions on the study of fifty cases of

<sup>1</sup> Medical News, February 6, 1904.

<sup>2</sup> Deutsche med. Wochenschr., vol. xxx., No. 24.

<sup>3</sup> Boston Medical and Surgical Journal, Feb. 25, 1904.

various diseases, treated with radium bromide, in quantity about 50 milligrammes, and of a radio-activity of about 1,500,000. The author presents the following summary of his observations :

“1. The rays from radium salts, unlike the X-rays, are not serviceable in diagnosis, either by means of radiographs or of fluoroscopic examinations. 2. The beta rays are useful as a therapeutic agent in certain skin diseases and new growths, if the diseased tissues are superficial or are not more than about 1.25 cm. (1-2 an inch) below the surface of the skin or accessible mucous membranes. 3. The beta rays from radium salts will heal some cases of new growths that are not healed by the X-rays, and they act more promptly, but not over so large a surface at one time as do the X-rays. 4. Radium salts of an activity of 8000, or considerably more, are not sufficiently strong to be efficient. Pure radium salts, which have a radio-activity of about 1,500,000, are not too strong for the work to be done. 5. The radiation from radium salts, unlike that from the X-ray tube, is uniform. 6. Great care should be exercised to avoid burns.”

Dr. Meyer and William J. Hammer treated favorably a large axillary cancer with radium of 300,000 activity. The exposure was one minute daily. While this case was incurable, the cancer grew smaller and less painful under the rays.

Lovell Drage<sup>1</sup> believes that, in cancer, radium first produces a leucocytosis, and then a fibrosis. In the case of pulmonary tuberculosis there is no difficulty in producing these conditions; in that of cancer much greater difficulty is experienced in advanced cases than is the case with tuberculosis.

Professor Havas observed a necrosis after the application of radium to a *nævus pigmentosus*, and considered its action similar to that of the Röntgen rays.

*Mode of Retrogression of Cancer Metastases under Radium Rays.*—Exner was able to trace histologically the retrogression of carcinomatous nodules in the mamma in one out of the two cases described. The findings were controlled by histological examination of excised, non-exposed nodules. He found that exposure for a single half hour was able to induce complete retrogression of a nodule. The retrogression was complete in five weeks. The most remarkable feature of the phenomenon is that while the cancer cells retrogress, none of the other cutaneous elements was destroyed. Within a week of the exposure there was a new formation of connective tissue, while at this time the cancer cells showed no change. There are numerous new formed capillaries in the new connective tissue. No change appears in the cancer cells until two weeks have elapsed. The rapid proliferation of connective tissue seems to diverge the cancer cells and overwhelm them by its growth, actually squeezing them to death.

<sup>1</sup> British Medical Journal, December 12, 1904.

Holzknrecht treated several cases of cutaneous affections with the radium rays, of one application each. One was a case of psoriasis gyrata of the entire body, which had been nearly cured with the X-rays and the cure was completed by the application of the radium. Very slight and brief applications of the X-rays are enough to cure psoriasis. The patches heal, while the sound skin is not affected by the applications. The same is true of the radium.

Francis H. Williams<sup>1</sup> has employed radium in forty-two cases, and states that of the patients treated, 9 were suffering from acne, 2 each from eczema and psoriasis, and 4 from lupus vulgaris. Of the 33 remaining, 1 was keloid, 5 were cases of rodent ulcer, 23 of epidermoid carcinoma, and 4 were cancer of the breast. The keloid case has improved, 2 of the 5 cases of rodent ulcer have healed, and three show improvement. Of the cases of epidermoid cancer, 11 have healed and 12 are improving. The author made experiments to test which were the more beneficial, the *beta* or the *gamma* rays from radium; these showed that the *beta* rays do not penetrate, and are therefore suited for superficial treatment, while the *gamma* rays have a marked power of penetration. His conclusions are as follows: That there is much similarity between the action of the radiations from radium and the Röntgen rays; that if the results obtained by radium prove permanent, this new therapeutic agent may be largely used instead of the Röntgen rays; also that certain diseases promise to yield more readily to treatment by radium and others to the Röntgen rays. He argues that a disease that has attacked different parts of the body of a given patient may be better treated in certain regions by radium, and in others by the Röntgen rays. And, lastly, that it is quite possible that, in some cases, the two remedies used together on the same area and at the same sitting may accomplish better results than either employed alone.

Lassar<sup>2</sup> gives illustrations of a number of patients with melanoma or canceroid cured by application of 1 mg. of radium bromide, in a small capsule of lead foil, upon a sheet of mica. He thinks that his experience justifies him in proclaiming that neoplasms can be cured with radium in the hands of any physician.

M. Danlos<sup>3</sup> reports a case of lupus of the face exposed to the action of a salt of radium, at two points, which had a radio-activity of 19,000 from 24 to 36 hours. The result was disappearance of the disease, with the formation of a smooth, white cicatrix, blending into the surrounding normal tissue.

MM. Hallepeau and Gadaud<sup>4</sup> report that too prolonged exposure to the emanations from radium led to ulcerations which lasted from five to six months. Dr. Blandamour has also used radium in lupus. His

<sup>1</sup> Medical News, Feb. 6, 1904.

<sup>2</sup> Dermat. Zeit., Berlin, p. 1599.

<sup>3</sup> Revue d'Électrothérapie et Radiothérapie, Nov. and Dec., 1902.

<sup>4</sup> Ibid.



best results followed the use of salts with a radio-activity of 5200 and 19,000 respectively.

The exposures were made for from twenty-four to forty hours, and were followed by marked erythema with maceration of the tissues exposed, and even ulceration. The recovery was perfect and the cosmetic effect good, the resulting scar being white, smooth, and soft. By modifying the power of the radium and shortening the exposure, he expressed the hope that the desired effect might be obtained without ulceration.

Two cases reported to the Viennese Society of the Imperial Academy of Science<sup>1</sup> had been submitted to the action of radium. One, a man aged 62, had been repeatedly operated on for cancer of the palate and lip, but with no benefit. Further operative measures had been declared useless. In the published report, the radio-activity and technic were not given, but a bromide of radium was used. The tumors gradually and completely disappeared. The patient was treated in the clinic of the late Prof. Gusenbauer. The second case was one of melano-sarcoma which was also reported cured.

Wm. Allen Pusey<sup>2</sup> believes that the effects and the therapeutic uses of radium are in some respects inferior but quite analogous to the action of the X-rays, and that radium finds a promising field in the treatment of lupus and cutaneous cancers.

Einhorn<sup>3</sup> makes some observations on the method of radium treatment, its physiology and diagnostic value, and on the therapeutic results he has obtained in the treatment of carcinoma of the œsophagus. Nine cases of œsophageal cancer were treated, of which six showed some improvement. Three cases were not improved. None of these latter received adequate treatment. Pain was diminished in some of them. Dr. John B. Shober has devised the radiode, for radium applications to the less accessible cavities. (Fig. 240.)

Dr. Mackenzie Davidson,<sup>4</sup> of Charing Cross Hospital, London, reports a case of cancer of the nose cured by the same means. Four exposures, aggregating an hour altogether, were given at intervals of a few days. In three weeks healing was progressing satisfactorily, and in six weeks the growth was all gone.

Foveau de Courmelles<sup>5</sup> describes numerous experiences to show the great sedative power possessed by radium. It soothes pain, whether organic or cancerous, nervous or neuralgic. Some cases of facial neuralgia and one of sciatica, long rebellious to other measures, yielded to the action of the radium rays. The girdle pains in two cases of ataxia were

<sup>1</sup> New York Medical Journal, August 15, 1903.

<sup>2</sup> Journal of the American Medical Association, July 16, 1904.

<sup>3</sup> New York Medical Record, July 30, 1904.

<sup>4</sup> Journal of the American Medical Association, June 25, 1904.

<sup>5</sup> Progrès Médical, May 28, 1904.

cured, one by the radium and the other by the Röntgen rays. The subjects were not informed in regard to the nature of the treatment, so he thinks that suggestion may be excluded.

Robert Abbe<sup>1</sup> employs only large quantities of stronger radium.

15 centigrammes Curie radium, strength .....	300,000
21 milligrammes German bromide, strength .....	1,000,000
100 milligrammes German bromide, strength.....	1,800,000

The working unit of the most powerful and pure radium manufactured is 10 milligrammes radium bromide 1,800,000, and is best used in a small cell covered by a thin layer of mica.

He puts 35 of his cases in the lupus type, including the epitheliomata, and asserts that not one failed to show a marked improvement.

Twenty have been cured, at least for the time, and with the probability that many are permanent, but with a slight point or two of recurrence in some, which always have yielded to a short secondary treatment. Many of these were distinctly malignant epitheliomas.

His results have been so uniformly excellent in the treatment of the sareomata, that he unhesitatingly advocates radium therapy in these cases with the utmost confidence.

*Exophthalmic Goitre.*—Robert Abbe<sup>2</sup> reports a case of goitre undesirable for operation. An opening was made in the tumor, into which a tube containing radium was inserted and retained there for twenty-four hours. At the end of four months there was still a certain degree of tachycardia, but the tumor had contracted to one-sixth of its former size. Two possible explanations of the favorable action are given; there may be retrograde changes in all overgrown tissue, or there may be irradiation of the ganglia of the sympathetic, even of the thoracic and cardiac ganglia.

*Rabies.*—Tizzoni<sup>3</sup> describes two series of experiments which have attracted much attention. In the first, the virus was exposed *in vitro* to the action of the radium rays; in the second, animals were inoculated in the eye, or sciatic nerve, or under the dura mater with virus, and the part was then exposed to the rays, an hour a day for eight days. The results indicate that the radium rays destroy the virus of rabies both *in vitro* and in the living animal.

*Nævus.*—Hartigan<sup>4</sup> reports a case of nævus successfully treated by radium bromide. The first was a large port-wine nævus affecting the whole of one cheek in a woman of twenty-six years. The treatment lasted nine months, during which time thirty-nine exposures were given, varying from half an hour to an hour. The nævus entirely disappeared,

<sup>1</sup> Journal of the American Medical Association, July 21, 1906.

<sup>2</sup> Archives of the Röntgen Ray, March, 1905.

<sup>3</sup> Riforma Medica, Palermo and Naples, last indexed vol. xlv. p. 1818.

<sup>4</sup> British Journal of Dermatol., December, 1904; Treatment, April, 1905.

with the exception of a few untreated areas. The amount of radium used was 10 milligrammes. Usually within twenty-four hours an erythema occurred, followed by vesicles, which fell off as scabs in a few days, leaving behind a thin white skin.

*Radio-Active Treatment with Thorium.*—Tracy<sup>1</sup> illustrates the radio-activity of thorium and calls attention to its anti-fermentative property. He suggests two methods of using radio-activity in tuberculosis. One is by using a saturated solution of nitrate of thorium in a large shallow receptacle. A slight current of air can be caused to pass over the solution from a compressed air tank, while the patient is inhaling. With the nitrate of thorium there may be more or less free nitric acid; this must



FIG. 239.—HARTIGAN'S RADIUM APPLICATOR.—The applicator figured herewith has been made at the suggestion of Mr. Hartigan, F.R.C.S., Assist. Surgeon, Blackfriars' Hospital, and permits of the application of radium to hitherto inaccessible situations, *e.g.*, œsophagus, larynx, bladder, etc. It is practically the size of a No. 12 catheter for the bladder, suitable carriers being provided for internal and external application. The applicator has a spherical front of a material allowing of the utilization of the maximum efficiency of the radium.

be neutralized by passing the emanations, before inhalation, through a wash-bottle containing a saturated solution of sodium bicarbonate. The more satisfactory way, he thinks, is by heating the oxide of thorium by the Lieber apparatus. The procedure leaves in the lungs a fine film of radio-active matter, which in turn produces the phenomenon of induced radio-activity in the same parts, which may last for one or two days. This is shown by the patient, after inhaling thorium emanations, exhaling on a photographic plate which produces the ordinary effects on the silver salts. An inhalation given every day or every other day, he says, will keep the lung cells constantly in a radio-active and antiseptic condition. The heat emanating from a Lieber apparatus can be cooled by passing through a glass and

rubber tubing, and the inhalation may be given for a period of fifteen minutes at the outset, gradually increasing to half an hour. This method of treating tuberculosis will not interfere with medical, dietetic, or other treatment.

Sharp<sup>2</sup> reports two cases of pulmonary tuberculosis treated by inhalations from thorium nitrate solution. In both cases there was marked improvement, the patients being enabled to return to work. The apparatus employed consisted of an ordinary gas washing bottle, holding 500 c.c. of water, in which were dissolved 100 grains (6 grammes) of thorium nitrate. When dissolved, any excess of nitric acid was neutralized with

<sup>1</sup> Medical Record, January 23, 1904.

<sup>2</sup> New York Medical Record, June 4, 1903.



ammonia. Two patients may inhale the emanations continuously for an hour a day each at an interval of eleven hours, it taking about half that long for the gas to collect.

*Rheumatism.*—Manders,<sup>1</sup> in choosing a radio-active substance for the relief of rheumatic pain, favors thorium, because; (1) Its radiations are spontaneous and are not destroyed by a physical state or by chemical transformation; furthermore, they are practically inexhaustible and do not need stimulus from any outside source of energy; (2) though infinitely less radio-active than radium, thorium is much more active than uranium; it is rich in the penetrating beta rays, which are required for deep therapeutics, and poor in the X-rays, which provoke a destructive molecular change in the elements of the superficial tissues.

Hartigan,<sup>2</sup> who employs his radium applicator (Fig. 239), treated a woman of 66, with a scirrhus of the breast of 16 years' duration. She received forty applications of radium bromide, lasting twenty minutes each. Twenty milligrammes of radium were used. The pain disappeared, hemorrhage ceased, and the ulcer began to heal. Later the growth disappeared and the ulcer vanished.

I have made a comparative study of the values of radium and the Röntgen rays on a series of epitheliomatous cases. Half of the lesion was covered with lead when exposing to the X-rays, and, conversely, when the other half was exposed to the radium emanations, the remaining half of the face was shielded. From clinical and microscopic observation no



FIG. 240.—SHOBER'S RADIODE.—This radiode is especially designed to facilitate the application of radium for medical purposes, especially in cases where applications are made in the smaller cavities of the body. The radium is contained in an aluminium capsule shown on the tip of the radiode at "F". This capsule is attached to a slender rod. To prevent the capsule and radiode becoming fouled in use, a glass protecting tube or shield, with one end closed, is made to fit snugly over the radiode, as shown in Fig. "G". The radiode can then be inserted in a cavity without danger of contamination in any way. Instead of the glass protecting tube as shown in cut "G", we can supply a similar protecting tube of aluminium. It is known that glass has the effect of cutting off some of the radium rays, and for this reason some operators prefer to encase the radiode in an aluminium protecting tube. A lead-lined box is supplied, as shown at "H" in cut, for containing the capsule of radiode when not in use, thus protecting the operator. (Courtesy of Williams, Brown, & Earle.)

improvement or changes were evidenced from the radium therapy. The results from the use of the X-rays were in every way superior and gave good practical results. Further experiments are needed, and the possibilities of the radium are promising. In this country Piffard, William J. Morton, Dieffenbach, Rollin H. Stevens, and many others report favorable results from radium therapy.

<sup>1</sup> Archives of the Röntgen Ray, September, 1905.

<sup>2</sup> British Journal of Dermatology, December, 1904; Treatment, April, 1905.

## CHAPTER VII

### PHOTOTHERAPY.

IN order to grasp the principles involved in the study of phototherapy, it is necessary to understand the more simple elementary facts concerning the physics of light and the spectrum.

Regarding the nature of light, two theories have been advanced. Newton asserted that luminous bodies emitted infinitely small particles in parallel lines, which produced in the eye the sensation of light. Huyghens, whose view now generally obtains, formulated the theory that light is produced by waves or undulations, that are transmitted with inconceivable velocity through the atmospheric ether.

All light, whether natural, as that from the sun and other celestial bodies, or artificial,—i.e., the electric spark or ordinary flames,—is of a

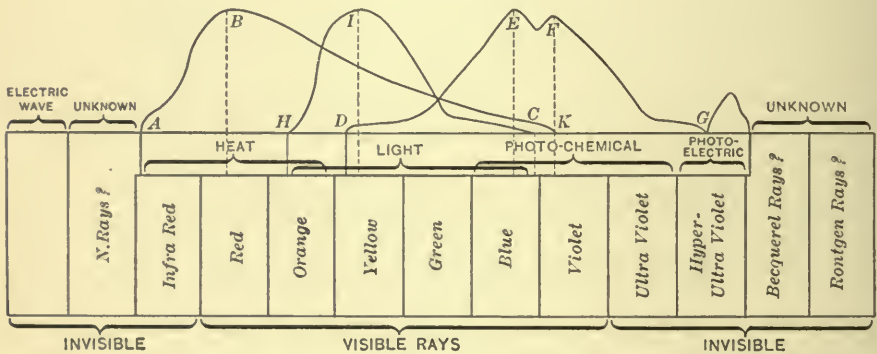

FIG. 241.—SOLAR SPECTRUM.—Scheme of the wave lengths of different radiations. A B C is the curve of thermal action; D E F G is the curve of chemical action; H I K is the curve of light action, with a maximum at yellow.

compound nature. If a ray of sunlight be suffered to fall upon a glass prism, it is diverted from its original direction, and, as its constituent colors are bent unequally, they are separated. When the transmitted light falls upon a white surface, the colors become visible, the tints blending where one color merges into another. This zone of blended tints is called the spectrum. The colors seen are violet, indigo, blue, green, yellow, orange, and red.

According to the undulatory theory of light, each of these constituent colors has its own rate of vibration. Red has the lowest and violet the highest rate of vibration; the former is least refracted or retarded; the latter undergoes most refraction or retardation. Different colors have

different wave lengths, diminishing from red to violet, so that those color rays in relation to the violet end of the spectrum are designated "rays of lesser wave length," and *vice versa*.

At the extremes of the solar spectrum are additional rays. Beyond the red rays lie the infra- or ultra-red rays; beyond the violet are found the ultra-violet rays.

The luminous rays of the sun are accompanied by others, possessing heating powers, the temperature increasing from violet to red. In the spectrum obtained by passing sunlight through prisms of rock salt, the highest temperature is manifested at a position far beyond the extremest visible red rays. From these facts, it is inferred that the great thermal rays of the solar system are at the same time the least refrangible.

Directly opposed to the heat-rays are the so-called chemical or actinic rays. The latter rays are capable of effecting both chemical combinations and chemical decompositions, as is evidenced in the blackening and decomposition of the silver salts in photography. As before intimated, these chemical rays lie beyond the violet end of the spectrum, and are the rays that are instrumental in effecting dermatitic changes. (Fig. 241.)

#### THE ACTION OF LIGHT ON PLANTS.

Plants cannot exist without light. Through its agency they extract CO<sub>2</sub> and by means of chlorophyll assimilate it. Light is not necessary for the germination of plants and seems to exert a retarding effect upon growth. This would seem to account for the varying rate of growth at different hours of the day. Indeed it has been shown that all light rays except the red and ultra-red retard the growth of plants, and that the effect is most pronounced in the rays that suffer most refraction in the spectrum.

"Heliotropism" is the faculty, possessed by many parts of plants, of turning toward and away from the direction of greatest light. Stems and leaf-stalks are *positively* heliotropic (growing toward the source of light, in the direction of the light rays), while roots and rhizomes are, as a rule, *negatively* heliotropic.

#### ACTION OF LIGHT ON BACTERIA.

That diffused and also direct light can destroy the bacteria of putrefaction was first enunciated by Downes and Blunt in 1877.<sup>1</sup> They likewise showed that the effect is the same whether the bacteria are moistened or dried, that the presence of oxygen is requisite, and that the manner in which light acts in these experiments is not to be sought in a modification of the nutritive basis. These data are now accepted by all scientists.

<sup>1</sup>Proceedings of the Royal Society of London, December 6, 1877, vol. xxvi. p. 488, and December 19, 1878, vol. xxviii. p. 199.



Dieudonné observed, in a series of most elaborate experiments, that bacteria were killed in thirty minutes by direct sunlight, in six hours by diffused daylight, in eight hours by the Brush light of 900 candle-power, and in eleven hours by the electric incandescent lamp. It is worthy of remark that very many observers have conclusively demonstrated that not only is the nutritive basis of bacteria unfavorably affected by light, but the protoplasm itself suffers a direct injury; it is in this way that street dust is in a great degree disinfected by its exposure to the direct rays of the sun.

#### THE EFFECT OF LIGHT ON ANIMALS AND MAN.

It is a recognized fact that many animals can develop only in the presence of light, and that its absence causes either a delay or a complete suspension of development. But not only is the general growth affected by varying the supply of light, but also the development of individual organs and parts of organs. At Finsen's clinics patients and nurses acquired a thicker growth of hair on those parts constantly exposed to the powerful electric rays.

The stimulus given to change of form and the transformation of energy through the agency of light is indeed remarkable. It is well known that the change of light causes change of form in the cutaneous contracting pigment-cells of many amphibians, reptiles, and fishes.

That ciliary movement is regulated or modified by varying the color of the light employed, is asserted by Uskoff, who observed that the epithelium of the œsophagus is equally swift in red and violet light, but is suspended if red light is substituted for previously acting violet. De Parville claims to have proved that the red end of the spectrum is nerve irritating, and the opposite end nerve soothing. On the higher animals, light produces marked effects on the cuticle. Those parts constantly exposed to the light become coarser and harder, the protoplasm becoming reduced to keratine. Indeed Moeller<sup>1</sup> demonstrated that light produces a hyperplasia and a horning process of the skin. Finsen and Moeller proved by experiment that skin which has been exposed to powerful chemical rays (blue, ultra-violet) retains for a long time (months and years) a peculiar tendency to react quickly (by reddening) to mechanical, thermal, and chemical stimuli.

We know that pigment is a protective to the skin against the action of the light rays. Freund<sup>2</sup> mentions the case of a dark-complexioned man whose body and face showed the presence of many vitiligo patches, who, after a long walk over the Grossglockner glacier, developed a violent erythema in the neighborhood of the white patches on the face, but in these regions alone. The remainder of the skin was unaffected.

<sup>1</sup> *Der Einfluss des Lichtes auf die Haut.* Biblioth. med., Stuttgart, 1900, p. 18.

<sup>2</sup> "Elements of General Radiotherapy," p. 420.

Finsen proved that acquired pigmentation may also have protective power against the injurious action of light rays. He painted with black pigment a ring around his arm. He next exposed the part to strong sunlight for three hours. After a time the skin appeared normal save at the edge of the painted belt, where some slight erythema was noted. A few hours subsequently a violent erythematous eruption developed in the exposed part, but the painted zone appeared unaltered. Again Finsen exposed the unpainted part to the sunlight; the result was the reverse, —*i. e.*, the white zone was destined to suffer an erythematous change, the remaining parts undergoing no alteration. Many observers have since shown that mild erythema and light pigmentations are due to the ultra-violet rays.

Blood absorbs light in a high degree, this being especially true of hæmoglobin. Oxyhæmoglobin gives a different absorption spectrum from methæmoglobin. Quincke<sup>1</sup> showed that hæmoglobin gives off its oxygen more quickly in the light than in the dark; hence light augments the oxidizing power of the blood and, correspondingly, the processes of oxidation in the human economy.

Godnew<sup>2</sup> found that persons and animals to whom daylight was accessible excreted more urine, urea, and chlorides than those remaining in the dark.

#### THERAPEUTIC ACTION OF LIGHT; ITS USE AMONG THE ANCIENTS.

The therapeutic value of light and the appreciation of its virtues are almost as old as civilization itself. Historical records show that light was valued as a remedial agent centuries ago in China, Mexico, Japan, the West India Islands, etc., the patients being subjected to sun-baths for therapeutic purposes, and others placed in total darkness as a means of punishment.

The ancient Greeks, who lived in flat-roofed houses, were accustomed to expose their entire bodies, after anointing them, to the sun, believing that its powerful rays acted very beneficently in bringing about and maintaining both health and beauty of the body. In the essays of Cicero and Vestricius we learn that the Romans were accustomed to sun-baths, these being frequently followed by cold sponges. Solaria, or out-buildings devoted to these baths, were quite common before the fall of the Roman Empire. Herodotus recommended sun-baths for those who were feeble and in debilitated health, and Antyllus also gave elaborate descriptions of the effects of the sun's rays upon the human body. Not only was the skin treated by "heliosis," but also such diseases as jaundice, nephritis, sciatica, rheumatism, nervous and mental diseases. During the Middle Ages this form of treatment was consigned to the limbo of oblivion. It

<sup>1</sup> Pflüger's Archiv, 1894, vol. lvii. p. 134.

<sup>2</sup> Zur. Lehre v. d. Einfluss d. Sonnenlichtes auf die Thiere. Kasanche Dissert., 1882.

was during the 19th century that the parasiticidal action of light engrossed the attention of bacteriologists, and it is due to their labors that the hidden secrets of light have been seized by eager experimentalists in the hope of discovering a reliable therapeutic agent.

#### TREATMENT WITH SUNLIGHT.

Sunlight is the most natural source of light, but its use depends on the weather, and upon other circumstances which affect the chemical intensity as well as the optical brightness. Long ago it was indisputably shown that the chemical intensity of light does not coincide with optical brightness. The chemical light-intensity of the sun's rays varies with the sun's height in the heavens. In the summer the chemical action of the sun and the blue light of the sky is far greater than during the winter season. The extent to which the air absorbs light varies with the amount of vapor, carbonic acid, and suspended dust in the atmosphere.

The chemical intensity of sunshine increases proportionately with a decrease in the atmospheric pressure. Thus, Timony found that the ultra-violet end of the solar spectrum extended much further toward the more strongly refrangible end at a height of 3500 meters than on the level of a table-land.

Ordinary sunlight is used as a remedial agent in the form of baths. The following is the *modus operandi*: Place the patient on a rug, elevate the head, and protect him from the wind, in a veranda entirely open to the south. Shield the eyes with dark glasses. The bath is best taken during the warm season. The first bath occupies a duration of fifteen minutes, which may be subsequently lengthened. During the bath the position is changed at intervals so that different parts of the body may be exposed to the light. Maintain these positions until violent perspiration occurs on these parts. This is to be followed by the usual water bath (70° to 80° F.). Have the patient massaged, and advise him to exercise thereafter.

#### TREATMENT WITH THE INCANDESCENT LIGHT.

The incandescent electric light is poor in violet and blue rays, and rich in yellow, red, and green. Its chemical action is, therefore, slight, but this, as well as its brightness, may be materially increased by strengthening the current. By this augmentation we not only affect the optical brightness, but also its blue and violet rays. Of normal power, 380 incandescent lamps have the same chemical effect as natural light at a distance of one metre. This form of treatment is of paramount value where the longer-wave rays are to be applied.

The modern incandescent baths are made for connection with the street electric wires. They consist of octagonal boxes supplied with panes of mirrors, with a movable lid above, for the patient's neck. (Fig. 242.)



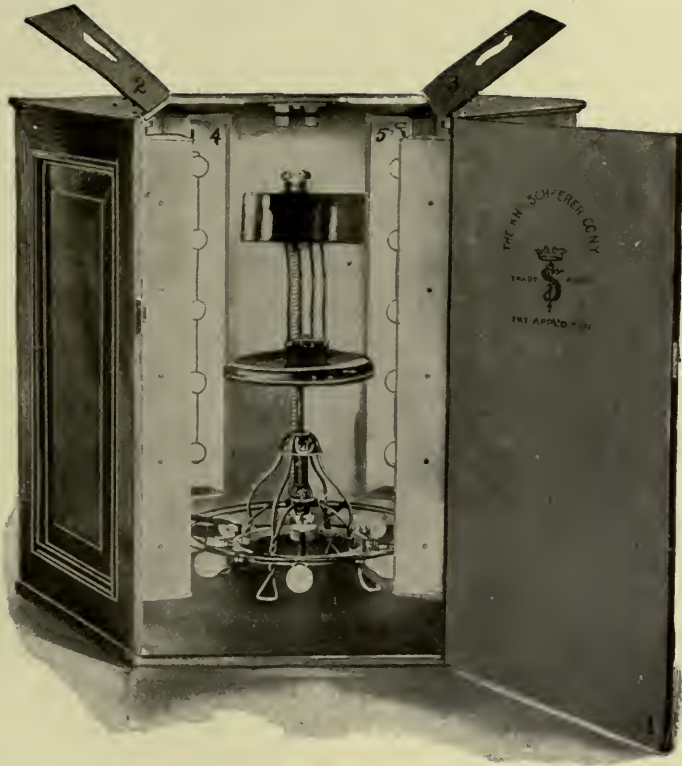

FIG. 242.—Cabinet for the treatment of diseases by the employment of incandescent lights.  
(Kily-Scheerer Co.)



FIG. 243.—The Finsen method of treatment.

Forty to sixty lamps, of 16 candle-power each, line the inner walls, and are so arranged that they can be put in, or withdrawn from within or without, by means of several switches in series, along vertical, horizontal, or spiral lines. The lamps are protected by a lattice work. A thermometer for measuring the inside temperature is fixed on the wall. A window is sometimes made in the wall of the chamber, through which the pulse and the course of the perspiration may be observed.

The patient is divested of his clothing and placed on a stool in the cabinet. All external light is excluded by a towel placed around the neck opening. An ice-cap is applied to the head. Begin the bath at a temperature of 110° F., and, if the patient reacts, gradually raise it to 155° or 165° F. The bath should be of a half-hour's duration. Increase the temperature by increasing the number of lamps, and also the strength of the current. Observe the pulse carefully, and after the light-bath employ the ordinary water bath or douche. The incandescent bath acts beneficially by radiating heat. In this way heat can be made to affect the deeper structures, and is more advantageous than the Turkish or Russian baths, which at best only exert an influence on the surface of the body. The most striking effect of this treatment is its action on the secretion of sweat, probably due to stimulation of the peripheral nerve endings, or by an elevation of the patient's temperature, or by a combination of both these factors. The incandescent electric light is of great value in muscular rheumatism, in the various forms of anæmia, in arterio-sclerosis, in valvular heart disease, in neurasthenia, migraine, tuberculosis, etc.

#### TREATMENT WITH THE CONCENTRATED ARC LIGHT.

Actinotherapy, or the treatment of disease by the application of light, was inaugurated by Finsen. Triumphant over the intense resistance that greeted his earlier efforts, the world to-day rings with his praises.

Sunlight is undoubtedly the best source of light, but, as it is not always available, it is necessary to have recourse to artificial illumination, especially to electric light. It is better to use the voltaic arc, for the light given by incandescent lamps contains too few chemical rays.

Finsen's method (Fig. 243) consists in concentrating actinic light, through rock-crystal lenses, on any desired part, rendered as exsanguine as possible by means of pressure, because the presence of blood acts as a barrier to the passage of the chemical rays to the tissues.

When the voltaic arc is used, 60 to 80 amperes of current are employed. The apparatus consists of the light, the cooling apparatus, and the light-concentrating apparatus. From the source of light there radiate four telescopes, for the four patients. The active rays are obstructed to a very slight degree by the lenses of rock crystal. The space



between the lenses is filled with water to moderate the temperature, and a surrounding water-jacket still further accomplishes this purpose. As the rays from this artificial light are divergent, the lenses are so arranged as to make them converge. The rays are brought to a focus by a water-cooled lens, held by the assistant, who presses the latter firmly on the part to be treated.

The applications are of about one hour's duration, and repeated daily. A few hours after treatment, erythema with some tenderness is often manifested, but there is no actual pain.

The reaction varies in different cases, but it is always seen in lupus vulgaris, perhaps never in lupus erythematosus. Following a few applications, most remarkable improvement frequently results. Twenty or twenty-five applications should always be given; after which the skin will usually present a soft, pliable, searless condition, save where destruction of tissue is marked by the earlier ravages of the disease.

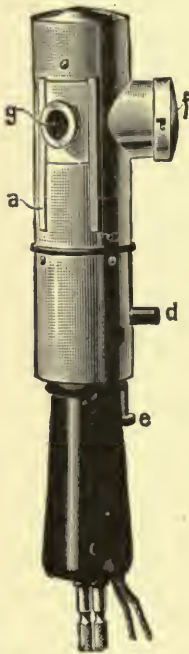

FIG. 244.—The dermo or iron electrode lamp.

THE DERMO OR IRON ELECTRODE LAMP.—  
(Fig. 244.)

As the chemical composition of the material composing the electrode defines the quantity of the ultra-violet rays, experimenters have been on the alert to turn this principle to advantage. Although many electricians battled with the problem only to find disappointment the price of endeavor, it remained for Bang, of the Finsen Institute of Copenhagen, to successfully construct a lamp with metallic electrodes suitable for phototherapy. By using iron electrodes, and tempering their heat by water-circulation, a lamp is produced that yields a maximum of chemical rays with a minimum production of heat. This lamp

is only adapted for the treatment of superficial skin diseases, as the rays are not penetrative but diffusible in character.

THE COOPER-HEWITT MERCURY-VAPOR LAMP.

Worthy of mention is the Cooper-Hewitt lamp,<sup>1</sup> described by Maurice Leblanc, and which briefly is as follows:

The lamp in its simplest form consists of a glass tube about 70 cm.

<sup>1</sup>Le Radium, Paris, June, 1905.

long and about 3 cm. in diameter. One end, the upper, is enlarged into a bulb, and contains a cup-shaped iron electrode which becomes the anode of the device. A small amount of mercury at the lower end is the cathode. In series with the lamp and connected at the anode end are a resistance and an adjustable self-reductor.

The well-known greenish color of the light given by mercury vapor when glowing under an electric discharge is spoken of by Leblanc. He also mentions some experiments of de Recklinghausen in mixing some other gases, such as argon and helium, with the contents of the tube. These were conducted with a view to correcting this serious defect, but as yet have not been successful.

This lack of red is not entirely without advantage in some situations, however. The Hewitt light has been found admirable for its non-excitability character, and it is also excellent for photographic purposes.

As glass absorbs ultra-violet rays, lamps have been made of quartz for special use in phototherapy in the treatment of lupus.

Most normal lamps take from 3 to 5 amperes of current, and have an efficiency of about 0.45 watt per candle-power. Several special forms of bulbs have been devised.

#### THE FINSSEN OR RED LIGHT TREATMENT OF SMALLPOX.

To Niels Finsen (Fig. 245), more than any one else, the civilized world owes a debt of gratitude for his untiring industry and indefatigable research in bringing the subject of the therapeutic action of light to the notice of the medical profession, and for having established his teachings upon a rational basis. So profound an impression did he make upon the minds of scientists that, in 1896, the government of Denmark founded a public institution for the purpose of carrying out the principles of phototherapy, and especially for the treatment of lupus and other cutaneous affections through the agency of concentrated chemical light.

From 1893 until almost the very day of his death, Finsen had been busily engrossed in the study and action of light treatment, but it is his labor to prevent the pitting from variola by excluding all but the red light that has won him deserved renown.

From his experiments at Copenhagen, he was able to prove that the blue, indigo, violet, and ultra-violet rays of the solar spectrum are the ones, and the only ones, that produce chemical effects upon animal tissues.

As far back as the sixteenth century, it was empirically recognized that the pitting from smallpox could be obviated by shading the doors and windows of the room with curtains of red material. Indeed, the use of this color fabric was first suggested by John of Gadesden in the fourteenth century, of whom Gregory remarked, "What think ye of a man, a prince, of royal blood of England (John, the son of Edward the

Second), being treated for smallpox by being put into a bed surrounded with red hangings, covered with red blankets and a red counterpane, gargling his throat with the wine of the mulberry, and sucking the red juice of the pomegranates? Yet this be the boasted prescription of John of Gadesden, who took credit of no meanness to himself for bringing his royal patient safely through the disease.”

In 1867 Black had published in the London “Lancet” an essay on the peculiar influence of light in smallpox, asserting that the complete exclusion of light, in spite of the fact that the patient had not been previously vaccinated, effectually prevented pitting of the face. In 1871 Waters published in the same journal a declaration that the severity of a case of variola was markedly modified by the exclusion of ordinary daylight.

In the same year, Barlow stated that he was able to distinguish a pronounced contrast in the two sides of a patient’s face, one half of which had been covered with colored gelatin to exclude all actinic rays, while the opposite half of the face was allowed to remain exposed to the influence of these rays.

Finsen, a poor and obscure medical instructor in a little Danish town, devoted his spare moments to experiments and observations upon light, with a hope of preventing the ugly disfigurement of smallpox. What he aimed to ascertain was the physiological effect of light on animal and vegetable tissues. As the result of the experiments he soon arrived at very important conclusions so far as the influence of light was concerned in the eruptive diseases, and notably so in smallpox. By simple reasoning he reached his first great discovery. He observed, when earthworms were placed in an oblong box covered half with red glass and half with blue glass, that they would invariably crawl away from the blue light, seeking shelter under the red light. In the light cast by the blue glass they were intensely active, restless, and ill at ease; in the red light they lay quiet, apparently perfectly contented.

With a chameleon he conducted a peculiar experiment. He placed the little reptile in such a position that one half of its body was under the light cast by blue glass and the other half in that cast by red. He noted that the parts of the animal’s body covered by blue light turned almost black, while the half covered by the red light presented an almost white color. From this he concluded that the creature had in its integument movable pigment-cells which acted as a barrier against the blue light.

Whilst in the midst of his experiments and researches Finsen wandered one day into a medical library in Copenhagen, where an article of Dr. Piteoe, published in 1832, attracted his attention. In this pamphlet it was mentioned that during an epidemic of smallpox among soldiers, those confined in dungeons suffered from the disease less severely, and recoveries occurred without any attempt at suppuration and consequent





FIG. 245.—THE LATE PROFESSOR NIELS R. FINSEN.—(Born in Farøe Island, Iceland, December 15, 1860. Studied medicine at Copenhagen University and received his doctor's degree in 1890. Awarded the Nobel Prize and the Cameron Prize for studies in practical therapeutics from the University of Edinburgh. Died September 24, 1905.)



scarring. Finsen grasped its meaning. "Red light contains no actinic rays," he reasoned; "why not use red glass in the windows?" this being physiologically the same as darkness. Thus, he suggested, the windows of the wards or rooms in the hospitals inhabited by sufferers from smallpox should have the white panes removed and replaced by dark-ruby glass panes. Personally he had never seen a case of smallpox, but he based his reasoning on theoretical grounds.

In 1893, the first trial of this therapeutic agent was made at Bergen, in Norway, by Dr. Lindholm, chief physician of the military service, and by Dr. Svendsen. Eight cases, four of them being of a severe type in children who had never been vaccinated, were treated, the results being a triumph for Dr. Finsen. Dr. Svendsen remarked, "The period of suppuration, the most dangerous and most painful stage of the disease, did not appear; there was no elevation of temperature and no œdema. The patients entered the stage of convalescence immediately after the stage of vaccination, which seemed a little prolonged. The hideous scars were avoided."

Control tests showed that smallpox cases exposed to daylight after beginning the red-light treatment invariably suffered suppuration and scarring, only a trifle of daylight sufficing to do harm, the irritated integument being almost as sensitive to the actinic rays as a photographic plate. A clear red light of such intensity as to permit the patient to read in the room is sufficient in ordinary cases. If the case be a very severe one, it is necessary to employ a red light of deeper or darker appearance.

The treatment of smallpox by the exclusion of the chemical rays of the sun has now been tried by a number of physicians, chiefly in Denmark, Sweden, and Norway. Practically all of these men have been favorably impressed with the results.

Mygind (Denmark) treated 22 cases (variola 12, varioloid 10); one died, the remainder upon leaving the hospital had hyperæmic spots only.

Abel (Bergen, Norway) had 23 cases, 8 of them very severe. One case, admitted very late, terminated in recovery, but with suppuration. In the others there was no suppuration and no scarring.

Backman (Fever Hospital at Koliikomaki) treated 62 serious cases, with 7 deaths; the remaining 55 recovered without scars.

Feilberg (Copenhagen) used the method in 11 cases. There was no secondary fever and no pitting. Pigmented or hyperæmic spots were present.

Strangard (Denmark) had 4 cases; all recovered with no pitting.

Benckert (Gothenberg, Sweden) treated 16 cases (5 were varioloid and 11 were variola); 3 died; one of the deaths was due to suppuration. Benckert remarks, "Suppuration is usually abolished, scars are extremely rare, and the duration of the disease is shorter."

Finsen, in summing up these cases, says that out of a total of 140 to



150 cases of smallpox, in one case only (that of Dr. Benckert) was the method inefficacious.

*The Conditions for Success by Finsen's Method.*—Two conditions are absolutely indispensable to obtain good results :

1. The patient should be placed under treatment *sufficiently early*. "When the patient comes under treatment early enough," Finsen asserted, "before the fourth or fifth day of the disease, suppuration of the vesicles, even in unvaccinated persons and in cases of confluent smallpox, will be avoided. Should the patient come under treatment after the fifth day of the disease, it is uncertain whether suppuration can be avoided. Sometimes this is the case, sometimes not."

2. "The chemical rays of daylight should be absolutely shut out. The efficiency of the method is so certain that, in case suppuration should occur in a patient who has been placed under the treatment in proper time, the first thing to be thought of is that, from want of care either on the part of the patient or of the nurse, daylight may have penetrated. Therefore, before the method can justly be declared a failure, the thoroughness with which it is carried out should be tested by exposing photographic plates or sensitized paper as a means of control in different places in the sick-room. If these photographic plates show the influence of the white light, the technique of the treatment has been imperfect. A few of those who have applied the method have at the same time treated the patient by other remedies as well. Such a course is objectionable for scientific purposes, as it is then impossible to decide which agency is responsible for the results. In order to give the experiments decisive scientific value, they should be carried out under strict control, and the patient placed under the treatment in proper time."

#### BLUE LIGHT.

Before closing, I wish to allude to the therapeutic use of blue and ultra-violet light. The subject is evidently still in its infancy, and much may be expected from the successes that are said to have followed its employment. Already there are many authorities who extol the efficacy of the concentrated actinic rays in the treatment of chronic ulcers, lupus, and other destructive cutaneous lesions.

*Blue Light as an Anæsthetic.*—Within recent years it has been found feasible to employ the visible chemical frequencies of the spectrum, by the use of screens of blue glass. This glass acts as a barrier to the passage of the frequencies of the ultra-violet portion of the spectrum, and shields from the frequencies beyond the blue or the yellow, the green and red frequencies.

Minin, of St. Petersburg,<sup>1</sup> believes that the visible chemical frequencies of the spectrum from the blue to the ultra-violet, by acting on the

<sup>1</sup> Journal of Physical Therapeutics, January 15, 1902.

vaso-motor nerves, are sedative and analgesic in nature. He asserts that the most beneficial results are to be found when the source of light is at a considerable distance from the area to be treated, thus refuting the hypothesis that the action produced is dependent upon residual thermal energy. Minin's view now generally obtains, that by the agency of isolated visible frequencies, constriction of the vessels and pronounced anaesthesia result; while white light effects directly opposite results.

Mr. H. Hilliard, anaesthetist at the London Hospital, has used blue light as an anaesthetic<sup>1</sup> after M. Redard's method.<sup>2</sup> He says: "Following M. Redard's plan, I have out of a total of thirty-two cases had twenty absolutely successful results, eight failures, and four cases in which the patients stated that they felt pain, and yet showed no sign of doing so beyond 'screwing up' their eyes during the operation. Most of the failures can, I think, be explained on the grounds that the patients were highly nervous, that they had while waiting their turn been told by others that some new experiment was being tried, and that they did not carry out my directions and keep their eyes fixed upon the light. The remainder may be explained, perhaps, by the fact that a different reflector was used, whereby the rays were not concentrated upon the patient's eyes, but were more widely diffused.

"In addition to the evidence advanced by M. Redard against the view that the influence of the light is hypnotic, I do not believe that so large a percentage of ordinary persons are so easily hypnotized, and I find that the results vary with the technic. I do not agree with M. Redard in the opinion that a general anaesthetic effect is produced, for I have found that, although sensation in the extremities is temporarily impaired, yet there is no real analgesia, this apparently only existing over the area of distribution of the cranial nerves.

"In all the successful cases dilatation of the pupils was observed, and in two or three, the eyes became fixed and the lids drooped, the patient developing a somnolent condition; but in those instances in which the patient moves his eyes constantly and blinks, the pupils will not dilate, and no analgesic effect should be expected."

<sup>1</sup> British Medical Journal, July, 1905.

<sup>2</sup> Lancet, May 12, 1905.

# APPENDIX

## TECHNIC OF RÖNTGEN RAY THERAPY

DURING the preparation of the present volume, I conceived the idea of addressing letters to some of the better known Röntgen therapists, asking that they supply the data of their technic on the blank enclosed for that purpose.

I was gratified by the cordial responses that my communications elicited, and interested in the widely divergent opinions, that have their adherents in this country and abroad.

The statements offered, in several instances, were so comprehensive that space was lacking to record the data. In those cases, an asterisk (\*) has been placed, referring the reader to a detailed explanation in the addendum.

The following abbreviations have been employed, which, like the tabulation itself and the addendum, are arranged in alphabetical order.

### COILS.

- A-N.=Apps-Newton.
- C.=Caldwell.
- Fes.=Fessenden.
- K. & K.=Kelley and Koett.
- K.=Kinraide.
- L.=Leeds.
- L. & N.=Leeds and Northrup.
- Q.=Queen.
- R., G. & S.=Reiniger, Gebbert and Schall.
- Ruhm.=Ruhmkorff.
- R. } Röntgen.
- R. M'fg. Co. } Röntgen Manufacturing Co.
- Sch.=Scheidel.
- Sn.=Snook.
- W. & B.=Waite and Bartlett.
- Will.=Willyoung.

### INTERRUPTERS.

- D.=Davidson.
- Gai.=GaiFFE.
- K.=Kinraide.
- R.=Röntgen.
- W.=Wehnelt.

### STATIC MACHINES.

- Columb.=Columbia.
- V. & T.= { Van Houten and  
          { Ten Broeck.
- Wag.=Wagner.
- W. & B.=Waite and Bartlett.

### VACUUM TUBES.

- F.=Friedlander.
- G. & B.=Green and Bauer.
- G.=Gundelach.
- M. & W.=Macalaster and Wiggin.
- Mach.=Machlett.
- Mon.=Monell.
- M.=Müller.
- Q.=Queen.
- W. & B.=Waite and Bartlett.



## ADDENDUM TO THE SYNOPSES ON TECHNIC IN RÖNTGEN RAY THERAPY

**BAETJER, F. H.** He uses 20 volts, ten amperes on two small coils; 110 volts direct current. He employs different makes of coils: Heinze 20-inch, Queen 9-inch, and Biddle 9- and 18-inch, respectively. He uses a hammerless interrupter on each 9-inch coil; the Wehnelt on the 18-inch. Vacuum tubes include: Queen, Heinze, Swett and Lewis, Müller, etc. He employs large (110 v.) and small (20 v.) coils; and believes that an erythema is necessary in all cases, except those of very superficial skin lesions.

**BARNUM, O. SHEPARD.** Barnum uses his own penetrometer, and remarks that his average length of treatment is entirely too variable to state. He protects the healthy part by placing a shield around the tube and lead-foil on the patient.

**BRENEMAN, PARK P.** Breneman varies the frequencies of his irradiations, giving treatments twice or thrice weekly and then again only three times every two weeks.

**CALDWELL, E. W.** Ten-inch coil of his own design, rotary mechanical break, 20 breaks per second; "break" lasts  $\frac{1}{10}$  second and the "make"  $\frac{2}{10}$ . Uses the aluminum screen for deep parts. For lupus, low penetration and no screen. He writes: "I use any old tube that is not good enough for radiographic work or that needs seasoning for that purpose." He declares that the static machine, for X-ray work, is useless.

**DUNHAM, KENNON.** He believes that a French tube is best; he also employs the Friedlander and the Gundelach. He has not found self-regulating tubes valuable, unless personally regulated. He says that the distance of the anode from the patient's skin varies, because he brings the glass to within one inch of the cutaneous surface. His voltage (primary) is 40 to 90, with load; 115, without load; and he has the anode red hot (usually), before treatment is finished. He regards the spintermeter and penetrometer as inaccurate, so that he prefers a new method. He protects the parts very carefully, but not close to the lesion. An erythema, he asserts, is necessary in lupus, mycosis fungoides, epithelioma, etc. He often gives daily treatment; at other times only once in two weeks.

**FRANKLIN, MILTON W.** He estimates the degree of vacuum of the tube by both the spintermeter and the penetrometer; preferring Holz knecht's method of standardization of the electro-scope and the Franklin electro-scope for general use. It is his practice to cover everything with lead except the lesion. The best indication to cease the treatment is the presence of any inflammatory sign on the healthy skin; his only other rule is, when excessive sloughing occurs on an open lesion.

**FREUND, LEOPOLD.** For superficial lesions, a soft tube (Wehnelt-skiameter), 5-12 cm.; for subcutaneous and deep-seated lesions, a hard tube (Wehnelt-skiameter), 10-15 cm. In treating the more deeply seated affections, Freund is guided by the green-blue light of the tube; in superficial affections, by a deep yellow fluorescence. He emphasizes the question of individuality, idiosyncrasy, etc., and advocates repeated small doses until slight reaction—i.e., swelling, redness, pigmentation, etc.—ensues. He protects the patient with lead-foil or mercurial plaster and urges the operator to seek his own protection in a lead apron, spectacles, etc. He believes that treatment should temporarily cease when inflammatory signs, with pigmentation, epilation, and subjective symptoms are evidenced. He formerly condemned the employment of Liquor Buronii as being an irritant in acute cases,<sup>1</sup> but recently he advocates the treatment, which I have appended, in his technic.

**GIBSON, J. D.** Gibson brings the anode close to the affected area in cutaneous lesions, and as distant as 18 inches for deep-seated influence. Amperage for deep penetration, 5 to 10, superficial, 1 to 2. For pulmonary cases, he employs a quantity of rays equivalent to that required to take a skiagraph in from 30 to 60 seconds. He

<sup>1</sup> Elements of General Radiotherapy, by Leopold Freund, translated by G. H. Lancashire, 1904, p. 348.

measures dosage by the fluoroscope and spark-gap. He ceases treatment at the appearance of an erythema or an elevation of temperature. He approves of the production of an erythema in malignant and superficial affections.

GIRDWOOD, G. P. Current of 220 volts from the street; in the hospital 110 v. For hospital use a 12-inch Biddle coil and a 10-inch Leslie Miller. In the office a 6-inch (Chadwick) mercury dip and a 12-inch Apps coil. He varies his interrupter according to his coil and tube, from 300 mechanical to 3000 electrolytic. He employs a voltage of 220 cut down by the rheostat to 200. He is guided in his dosage by a greenish-yellow fluorescence of the tube.

GRUBBE, EMIL H. A subdued fluorescence of the luminous hemisphere of the tube is his guide; the vacuum is estimated by the resistance of the tube, as compared with air resistance between the prime conductors of the generator. He protects the healthy parts by means of Grubbe's X-ray foil. He believes that an erythema is necessary in the treatment of all superficial lesions.

HALL-EDWARDS, J. He uses German and French makes of vacuum tubes, and finds the non-regulating best for radiography, the self-regulating for treatment. He uses all tubes, no matter what the vacuum, at from 4 to 12 inches. He employs the radiochromometer, radiometer, etc., for experimentation only. He protects the healthy parts by plaster of Paris masks and a bandage covered with lead-foil. He writes me that in all his varied experience—Officer in Charge of the X-ray Department of the Birmingham General Hospital and late of the Imperial Yeomanry Hospitals in South Africa—he has found nothing to relieve the painful, chronic dermatitis, from which he is a sufferer.

HEATHERINGTON, J. P. He uses his own water-cooled interrupter or the Kinraide, the number of interruptions in either being about equal to the Wehnelt. He uses a variety of vacuum tubes, among which may be mentioned: The Queen, Volt-Ohm, Friedlander, Wagner, Swett and Lewis, Müller, etc. He tells me that he prefers the non-regulating and the self-regulating, to the osmo-regulating, variety. For cutaneous lesions, he brings the anode as close as possible to the part, unless the affected area is very large; in deep-seated conditions, as low a vacuum as will penetrate to the desired depth. He only uses lead to protect special parts, such as the hair; and discontinues treatment at a commencing erythema, or disappearance of the lesion. He believes an erythema is necessary to obtain rapid results, or to remove hair. It is his aim to produce erythema in nearly every case.

HOLDING, A. The indication to discontinue treatment is a "slight erythema." He says that "a slight erythema may at times be necessary in superficial skin lesions, but even then it is to be avoided if possible." He believes that *prevention* is better than all the cures for X-ray dermatitis.

KIENBÖCK, ROBERT. He approves of the Benoist-Walter radiochromometer, average penetration 4 to 6, mostly 5. He uses his quantimeter in conjunction with Sabouraud-Noiré radiometer for dosage, and for comparison by artificial illumination he takes advantage of Scheiner's benzine lamp. He believes that a complete treatment by massive doses, once or twice monthly, is the most effective method. He is much opposed to frequently repeated irradiations.

LAQUERRIÈRE, ALBERT. The milliamperage in the secondary is measured by Gaiffe's milliamperemeter, the length of the spark by the spintermeter. The penetration is determined by the radiochromometer of Benoist, and the dosage by the radiometer of Sabouraud and Noiré. The occurrence of erythema causes him no fear, indeed he often looks for a certain determinate degree of it; he believes that its likelihood can never be rigorously excluded, as idiosyncrasy plays so largely the rôle. He asserts that an erythema is beneficial in certain rebellious cases of lupus and in some of the epitheliomata. The various kinds of apparatus devised by Gaiffe are much in vogue in France.

LEONARD, CHAS. L. Leonard uses, as protective measures, a lead-covered box, a lead-glass shield, and an aluminium screen. He believes an erythema necessary when the disease will not yield without.

MORTON, REGINALD. He advises the employment of the Apps-Newton coil. He finds that the best results in his work are accomplished by two ten-inch coils and one eighteen-inch. He estimates his dosage by the apple-green color of the tube,



with the anode dull-red. At the appearance of slight dermatitis he discontinues treatment. Nevertheless, he believes that the more severe the lesion, the more necessary it is to bring about definite but not severe reaction. Dr. Morton informs me that the London Hospital, to which he is the radiologist, treats the superficial cutaneous lesions, including rodent ulcer, in the department of dermatology; cases of malignant and constitutional disease are cared for in the electrical department under his supervision.

MORTON, WM. J. His guide in dosage is the fluorescence of the tube only. He doubts if an erythema is ever really necessary; asserting that in three weeks' time a mild erythema usually develops, followed by tanning. He employs only high-vacuum tubes, preferably old and "hardened"; these giving "a 'therapeutic' X-ray, in contradistinction to the quality of the X-ray best adapted to making a good skiagraph." He believes that his method is much safer as regards X-ray burns.

NEWCOMET, WM. S. He estimates the degree of vacuum by the appearance of the tube and spark-gap. He believes the time to discontinue treatment is when the treatment is no longer needed, and that an erythema is not necessary. He remarks that the occurrence of erythema is not necessary—it is accidental.

PANCOAST, HENRY K. Pancoast uses the mechanical spring interrupter for therapeutics; the Wehnelt interrupter for radiographic work; the Queen and Gundelach tubes for superficial treatment; the Queen, Macalaster and Wiggin tubes for deeper work. With the mechanical spring interrupter and a 24-inch coil, his amperage is 2 to 3; on 18-inch coils it is usually more. He estimates the vacuum of the tube by equivalent spark length when the tube is known to be reliable and constant; otherwise he resorts to the Benoist scale in addition. He tells me that his average length of treatment is a very variable quantity: for the average case of epithelioma, 10 to 15 minutes three to five times per week. He protects the healthy parts by the diaphragm of the tube shield, lead-foil or wet leather. He remarks that treatment should be discontinued when it is certain that the condition has been cured, and that the production of an erythema is a poor and misleading guide. As a prophylactic measure against X-ray dermatitis alcohol with talcum powder or stearate of zinc is recommended. The above will also answer for burns of the first degree, or an evaporating lotion of lead water and laudanum may be used for a slight dermatitis. For burns of the second degree: dry powder; lead water and laudanum; zinc oxide ointment; or picric acid solution 1-1000. For burns of the third degree: zinc ointment, or picric acid solution. For pain: lead water and laudanum or orthoform. For burns of the fourth degree: the same; to be treated more as a surgical condition. Chronic ulceration of the patient, Pancoast regards as a surgical condition. In some cases picric acid has been satisfactory. If healing is obstinate, excise, allow the ulcer to heal, or skin graft, or suture the edges together.

PFÄHLER, G. E. He employs a 7-inch Leeds coil and a number of coils of the Röntgen Manufacturing Co.—9-, 15-, 18-, and 20-inch. The vacuum tubes that he prefers include: Heinze and Bauer, Green and Bauer, Müller, Friedlander, Machlett, Macalaster and Wiggin. He is of the opinion that a dermatitis or toxæmia is a danger signal for the operator, and that it is seldom necessary to produce an erythema except when irradiating superficial lesions.

PRICE, WESTON A. He uses a large number of coils, interrupters, and tubes, but fails to give their make or names. The distance of the anode from the patient's skin varies; usually it is from 6 to 10 inches. He states that his vacuum tubes also vary very much in superficial, subcutaneous, and deep-seated conditions. "For my dental work," he writes, "I use very high amperage and very high penetration, modifying these with different conditions."

RUDIS-JICINSKY, J. With the static machine, 200 to 300 revolutions per minute for therapy, 500 for skiagraphy. Length of spark-gap, 18 inches (maximum). In therapy he also employs a 12-inch coil with two layers of primary connection in series; interruptions, 10 per second; primary current, 2½ amperes; direct current, 110 volts. For superficial lesions he is guided by a yellow-green fluorescence of the tube; for deep affections, by what he terms "a perfect green." He varies his length of treatment "according to each individual case, the condition of the patient, and the condition of the tube." He informs me that in his belief all "deep" cases should undergo a "tanning," and that the production of an erythema is only justifiable in a few obstinate diseases.



SCHAMBERG, J. F. He uses Queen, Müller and Gundelach (regulating) tubes. One-fifth to two-fifths milliamperes with medium high tubes; three-fifths to one and three-fifths milliamperes for low tubes. For accurate dosage Schamberg depends upon Benoist's radiochromometer; regarding No. 3 as fairly exact for superficial lesions, and from 6 to 8 for the deeper varieties. The average length of treatment in cutaneous affections is 5 to 6 minutes twice or thrice weekly. He asserts that erythema, especially if it occur early following vigorous treatment, is an indication that the irradiations should be discontinued. It is his belief that in ordinary cutaneous affections, such as acne, an erythema is not a *sine qua non*, but that its production acts as a remedial measure.

SCOTT, J. N. Scott says: "I try to use the same tube on the same patient. Upon beginning treatment, I record the length of treatment, amperage, number of interruptions, spark-length that the tube will 'back up,' etc. I gradually lengthen the treatment until an erythema is evidenced, basing future treatments on the above data." He irradiates epithelioma every day, and deeper growths every second or third day. He protects the patient by a metallic box which has adjustable openings for the passage of the rays. He believes that an erythema is necessary in every case, except when the eye is involved.

SHOBER, JOHN B. He judges of the dosage by a whitish-yellow to a light green fluorescence of the tube; the anode normal to cherry-red. He estimates the degree of vacuum by the spark-gap on the coil and tube, the amperage in the primary current, the degree of the fluorescence in the fluoroscope, etc. He discontinues treatment if the case is getting worse, instead of better ("toxæmia"). He says: "Of late I prefer to use Curie 300,000 radium bromide, 20 milligrammes in two aluminium capsules, 2 to 3 times weekly, from 1 to 3 or 4 hours; valuable in furunculosis, boils, carbuncles, moles, warts, nævi, epithelioma, sarcoma, etc."

SMITH, J. F. Dosage is determined by a light to dark green fluorescence of the tube; "the heavy anodes," he asserts, "do not get red hot." He believes that the best time to discontinue treatment is at the appearance of any erythema, taking into consideration the duration and number of the exposures.

STEWART, THOS. J. For superficial conditions he uses a Queen tube or one that can be kept low. In his work he employs the Gundelach, Queen, and Müller tubes; using the first and last for therapy. He believes that the maximum quantity of rays is emanating from the tube when the anode is of a dull red color. He thinks it necessary to produce an erythema to determine the maximum individual dose.

STOVER, G. H. Stover uses a great variety of coils, interrupters, and tubes. Among the coils may be mentioned: Heinze 12-inch, Scheidel 12-inch, Meyer 6-inch, etc. The vacuum tubes include Green and Bauer, Macalaster and Wiggin, Swett and Lewis, Müller, etc. In estimating the vacuum of the tube he takes into consideration the primary current, the appearance of the tube, and the spintermeter-gap. He gives ten minutes' treatment to cutaneous diseases and from 10 to 15 minutes' for subcutaneous and deeper affections. He believes that the best time to discontinue treatment is at the approach of cure or transient or definite erythema. He asserts that in lupus vulgaris and cutaneous epithelioma, the production of an erythema is necessary.

WALSH, DAVID. Walsh writes me that of late he has not followed up the therapeutic aspect of the X-rays, beyond treating a few cases of ringworm, recurrent carcinoma, and rodent ulcer. He remarks that his publications contain much of his technic.



Number			A. STATIC OR INFLUENCE MACHINE						
	NAME	Residence	1. Variety and Make			Diameter of the Plates		Length of Spark-Gap	
			1	2	3	Inches	Cm.	Inches	Cm.
1	Baetjer, F. H.	Baltimore, Md.							
2	Barnum, O. S.	Los Angeles, Cal.	W. & B.	8	120-360	30	75	16	40
3	Breneman, P. P.	Lancaster, Pa.							
4	Caldwell, E. W.	New York, N. Y.							
5	Dunham, Kennon	Cincinnati, O.							
6	Franklin, M. W.	New York, N. Y.							
7	Freund, L.	Vienna							
8	Gibson, J. D.	Denver, Col.	V. & T.	8	Vary	32	81		
9	Girdwood, G. P.	Montreal	Betz	12		36	92		
			W.		300	36	90	18	45
10	Grubbe, E. H.	Chicago, Ill.		16	50 to 100	30	75	12	30
11	Hall-Edwards, John	England							
12	Hetherington, J. P.	Logansport, Ind.	Wag.	4	1200	30	75	14	35
13	Holding, A.	Albany, N. Y.							
14	Jones, H. Lewis	London							
15	Kienböck, Robert	Vienna	Ebonite.	10	800-1200	22	55		
16	Laquerrière, A.	Paris							
17	Leonard, Chas. L.	Philadelphia, Pa.							
18	Marsh, Jas. P.	Troy, N. Y.							
19	Morton, R.	London							
20	Morton, Wm. J.	New York, N. Y.	V. & T.	15	300-600	32	80	12	30
21	Newcomet, Wm. S.	Philadelphia, Pa.		6		26	65	12	30
22	Pancoast, H. K.	Philadelphia, Pa.							
23	Pfahler, G. E.	Philadelphia, Pa.							
24	Price, Weston A.	Cleveland, O.							
25	Rudis-Jelnsky, J.	Cedar Rapids, Ia.	V. & T.	10	200-300 *	32	80	18	45
26	Schamberg, J. F.	Philadelphia, Pa.							
27	Scott, J. N.	Kansas City, Mo.							
28	Shober, John B.	Philadelphia, Pa.							
29	Smith, J. F.	Chicago, Ill.							
30	Stewart, Thos. J.	Philadelphia, Pa.							
31	Stover, G. H.	Denver, Col.							
32	Walsh, David	London							



# TGEN THERPAY.

## RATUS.

B. SOURCE OF CURRENT	C. COIL			D. INTERRUPTER		E. CROOKES VACUUM-TUBE
	Variety or Make	Length of Spark-Gap (Parallel)		1. Mechanical	2. Mercury	1. Non-regulating 2. Self-regulating 3. Osmo-regulating 4. Variety and Make
		Inches	Cm.	3. Wehnelt	4. Caldwell	
1. Accumulator, Capacity				5. Simon		
2. Direct Current				6. Interruptions per minute		
3. Alternating Current						
4. Transformer						
(2) 110 volts .....	H. Q. B. ....			1,* 3,* (6) variable.....		2,* 3, G., Q., H. M.....
.....	Western .....	12, 16, 18	30, 40, 45	2, 3, (6) 120 to 1200 .....		2, (4) M., F.....
(2) 110 volts .....	Q.....	15	38	1, 2.....		1, 2, (4) Q., M., G.....
(2) 110 volts .....	C.....	10	25	1* (6) 1200.....		G., M.*.....
(3) 115 volts .....	Sch., K. & K..	18, 12	45, 30	My own, (6) variable.....		1, 2, (4) F., G.*.....
.....	Will., W. & B.	8, 12	20, 30	3, 4.....		2, (4) G., G. & B.....
(2) 110 volts .....		10	25	3.....		2, 3, (4) G., M.....
(2) 220 volts .....	K., W. & B....	10	25	1, K., 3, 4.....		2, (4) M.....
.....		12	31			
(Q.) *.....	Vary*.....			1, 2, 3, 4, (6) 300-3000*.....		1, 2, 3, 4.* .....
(1) 14 v 30 a-h. (2) 110 (3) 220.		40, 20	90, 50	1, 2, 3, (6) 120 to 3000.....		2, 3.....
(2) 220 volts .....	Coxe, home-made.	12, 15½	30, 4½	1, 2, 3, (6) D., Gal.....		1, 2, 4.*.....
(1) 10 cells 21 volts.	Q., Sch., K....	18, 12, 12	45, 30, 30	K. and my own .....		(1) some, (2) prefer, 3, 4*
(3) 100 volts.	W. & B., K. & K.	8, 12	20, 30	3, 4, W.....		2, (4) W. & B.....
(2) 110, (4) valve, k.k..						
(2) 100 volts .....		12	30	1, 2, 3 .....		3.....
(2) 110 volts .....	R., G. & S....	16	40	2, 3.....		2, (4) M.....
(2) 110 v.; (4) Gaiffe.....	Gaiffe .....	10	25	(2) Gaiffe.....		2, 3.....
(1) 10-20 volts .....	L. & N.....	4, 7	10, 17½	1.....		(2) Q., M., (3) G.....
(2) 110 volts .....	Q.....	12	30	(1) Queen .....		2, (4) Q., M., F.....
(2) 70 volts .....	A-N.....	10, 18 *	25, 45	1, (6) 600-2000 .....		2, 3.....
(2) 80 volts .....	Will.....	18-20	45-53	1, 2, 3, my own, (6) 3000-40,000.		3, (4) M., G.....
.....	L., Sn., Q.....	18, 20, 12	45, 51, 30	1, 3.....		1, 2, Q., M., F., G.....
.....	R. Mfg. Co.....	18, 24	45, 61	1, 3*.....		(4) Q., G., M. & W.....
(1) 16 volts; (2) 110 v.	L., R. Mfg. Co.*	9, 18	23, 45	1, 3.....		2, 4*.....
(2) 110 volts .....		16	40	1, 2, 3, 4 .....		1, 2.....
.....	Sch., Ruhm....	20, 12, 8	50, 30, 20	1, 3.....		2, (4) G., M., Mon.....
(2) 110 volts .....	Q.....	20, 12	50, 30	1, 3.....		4* .....
(2) 110 volts .....	Sch., Fes.....	20, 18	50, 45	1, 3, (6) 800.....		1, 2, 3, (4) many .....
(1) 20 volts .....	R.....	9	23	1.....		2, (4) Q.....
(2) 110 v.; (4) Rotary-Mercury.	Sch.....	12, 14, 22	30, 35, 55	2, 3.....		2, (4) F., G., M. & W.....
(2) 110 volts .....	Q., L.....	12, 18	30, 45	1, 3, (6) 600.....		2, (4) Q., G., M.*.....
.....				2, 3, 4.....		2, 3, (4) *.....
(2) 200 volts.....	A-N.....	12	30	2, D.....		Bi-anodal.....







Number—Continued	I. VACUUM TUBE EMPLOYED			II. DISTANCE OF ANODE FROM PATIENT'S SKIN						III. EQUIVALENT VACUUM		
	Superficial	Sub-cutaneous	Deep-seated	Soft or Low Vacuum		Medium		Hard or High Vacuum		Superficial		Sub-
				Inches	Cm.	Inches	Cm.	Inches	Cm.	Inches	Cm.	
1	Soft....	Medium	Hard ...	8	20	6	15	5	12½	1½	4	2-2½
2	Low ....	Medium	High....	5-9	13-23	8-12	20-30	12-30	30-75	2-3	5-7½	3-4½
3	Low ....	Medium	High....	6-12	15-30	9-15	23-38	12-20	30-50	3-6	7½-15	6-8
4	Low ....	Medium	High....	5	12½	12	30	20	50	1	2½	2
5	Very soft	Medium	Hard ...	*	.....	6-8	15-20	15-20	38-50	.....	.....	.....
6	Very soft	Soft....	Medium or hard.	5-8	13-20	6-8	15-20	12-15	30-38	4-8	10-20	4-8
7	.....	.....	.....	2-5	5-12	.....	.....	4-6	10-15	1½-2	3-5	2-3
8	Low .....	.....	Medium	*	.....	*	.....	*	.....	2-3	5-7½	2-2½
9	4½"-5"	5"-6"	5"-7"	.....	.....	.....	.....	.....	.....	.....	.....	.....
10	Low ....	Medium	High....	2-5	5-12½	4-7	10-17½	6-8	15-20	1-3	2½-7½	3-5
11	Medium soft.	.....	Hard ...	*	.....	*	.....	*	.....	3-5	7½-13	4-6
12	*	*	*	*	.....	.....	.....	*	.....	1½-2	3¾-5	2-4
13	Low ....	Medium	High....	3-6	7½-15	6-10	15-25	6-20	15-50	1	2½	2
14	.....	.....	.....	.....	.....	.....	.....	.....	.....	.....	.....	.....
15	.....	.....	.....	.....	.....	.....	.....	.....	.....	8	20	.....
16	.....	.....	.....	6	15	.....	.....	10-12	25-30	1½-2½	3-6	1½-2
17	.....	.....	.....	2-8	5-20	8	20	8-20	20-50	¼	⅝	1½
18	Low ....	Medium	High....	3	7½	5	13	10	25	3	7½	6
19	.....	Medium	Hard ...	4	10	6	15	8	20	4	10	5
20	.....	.....	.....	*	.....	*	.....	*	.....	7-12	17½-30	7-12
21	Soft .....	High....	High....	4-10	10-25	4-10	10-25	10-20	25-50	1	2½	2
22	G., Q. ...	Same ...	Q.M.&W.	7-9	18-23	8-12	20-30	12-18	30-46	½-1	1½-2½	1-1½
23	Soft....	Medium	Hard....	6	15	10	25	12-15	30-38	1½	3¾	2
24	*	*	*	*	*	*	*	*	*	¼-1	⅝-2½	1½
25	Low ....	Medium	High,old	.....	.....	.....	.....	.....	.....	3-4	7½-10	4-5
26	Medium low.	Medium high.	.....	.....	.....	5-7	13-17½	12-15	30-38	.....	.....	.....
27	Soft....	Medium	Hard ...	8	20	10	25	18	45	1	2½	1-2
28	Low ....	Medium	High....	6-10	15-25	10-12	25-30	12-18	30-45	½-1	1¼-2½	1½
29	Low ....	Medium low.	Medium high.	6-8	15-20	8-10	20-25	10-14	25-35	.....	.....	.....
30	Q.* .....	Medium soft.	Medium	6-8	15-20	8-10	15-25	10-15	25-38	½-1	1¼-2½	1-2
31	Soft to medium	Medium	Medium to high.	3-8	7½-20	10-15	25-38	15-30	38-75	.....	.....	.....

# EN THERAPY—Continued.

## NIC.—Dosage.

MARK LENGTH OF PLOYED			IV. CURRENT			Splantermeter	V. PENETRATION	VI. CHEMICO-PHYSICAL	VII. PHOTOMETRIC COMPARISON BY	
Superficial	Deep-seated		Primary Coil		Secondary Coil		1. Radiochromometer (Benoit) 2. Penetrimeter (Walter)	1. Chromodionometer (Holzneck) 2. Radiometer (ScheutroodNoiré) 3. Freund 4. Quantimeter (Kienboek)	1. Radio-Activity 2. Artificial light 3. Selenium cell (Kathmer Levy) 4. Ionization (Franklin)	1. Fluorescence of Tube 2. Appearance of Anode 3. Thermometer (Köhler)
Cm.	Inches	Cm.	Volt	Amp.	Milliamp.					
5-6¼	4-6	10-15	.....	5	.....				1. Yes.....	
7½-11	4½-5½	11-14	110	1½-24	.....	2				
15-20	8-12	20-30	110	.....	.....	2			1, 2 (red).....	
5	5	12½	110	3-6	1	2				
			*	2-12	.....	(1) 3 to 8	1, Approx.			
10-20	6-8 +	15-20+	115	5-8	15-60	4-10	1, 2.....	4		
8-8-10	4-8	10-20	110	3-6	.....	*	3*		1*.....	
	3-6	7½-15	220	1-2* 5-10	.....	*	2*			
			220*	.....	.....				1*.....	
½-12½	5 +	12½ +	.....	.....	3-15	*	*			
10-15	8-14	20-35	60	5-15	1-5	.....	(1) About 7		(1) partly, (2) red hot.	
5-10	3-5	7½-13	21	2½-5	.....	2			1, (2) on some tubes.	
5	4-6	10-15	80-120	4-8	0.5-2.0	.....	(2) 4-6			
			.....	.....	.....	1	2			
.....	12	30	70	3	0.2-0.6	.....	1*	2*, 4*	2*	1, 2.....
4-7	2-4	5-10	.....	.....	Gaiffe*	Yes	1	2		
¾-5	2½-5	6¼-13	20	4-10	1-6	¼-6				
15	8	20	.....	.....	.....	Yes				
13	6-8	15-20	70	2-8	1	Yes			1, 2*.....	
7½-30	7-12	17½-30	.....	.....	.....				1.....	
5	4	10	.....	.....	.....				1, (2) red.....	
2½-4	2-4	5-10	110	2-3*	*	.....	(1) 3 superficial 6 deep.			
5	3	7½	110	2-5	1	.....	1			
¾-10	1-10	2½-25	.....	.....	.....					
10-13	5-6	13-18	110	2½	.....	1, 2.....			1.....	
			110	5	*	1*			1*.....	
2½-5	2-4	5-10	110	3-8	.....	Yes	1			
¾-5	2¼-4	6½-10	20	2-4	.....				1, 2*.....	
			110	2	.....				1*.....	
2½-5	2-4	5-10	110	5	Yes	Yes	2		1, 2*.....	
			.....	3-6	.....		(1) 1-4 or 6 B.		1, 2, partly....	







### DOSAGE AND CLINICAL ASPECT

Number—Continued

	1. Do you vary the length of treatment?	2. What is your average length of treatment? How often per week?	3. Do you protect healthy part, and how?	4. What is the best indication to discontinue treatment? Is it a mild erythema?	5. When do you believe an erythema is necessary?
1	Yes .....	5 minutes; thrice .....	Lead-foil .....	Yes .....	* .....
2	Yes .....	Varies; daily to 3 weekly.	Yes * .....	Mild erythema .....	Malignancy .....
3	Yes .....	* .....	Yes, shield .....	Erythema generally ..	Superficial cases ..
4	.....	10; 1 to 3 .....	Tin-foil .....	Yes .....	Lupus .....
5	Yes .....	12 minutes * .....	.....	Tanning sometimes ..	* .....
6	When indicated ....	5 minutes; 2 to 3 .....	Lead * .....	* Yes .....	Very rarely .....
7	Yes * .....	.....	Yes * .....	* .....	* .....
8	Yes .....	7½ minutes; thrice ...	Yes, for eye and hair ..	* Very mild .....	* .....
9	Yes .....	5-10; daily to monthly	Lead shield .....	Skin redness .....	Lupus * .....
10	Rarely .....	10 minutes; daily .....	Yes * .....	Dermatitis .....	* .....
11	Yes .....	5 minutes; thrice .....	Yes * .....	Slight dermatitis .....	Always .....
12	Yes .....	3-5 minutes; 1-3 days.	Lead .....	* Prefer .....	Usually * .....
13	Yes .....	5 minutes; 3 times .....	Lead .....	* Yes .....	.....
14	.....	10 minutes; twice .....	Lead-foil .....	Yes .....	.....
15	Yes .....	Varies .....	Lead * .....	.....	Usually .....
16	Yes .....	.....	.....	* .....	* .....
17	Yes .....	10 minutes; thrice .....	Lead .....	? Yes .....	* .....
18	Yes .....	10 minutes; thrice .....	Tin-foil .....	Hyperæmia some- times.	Skin lesions .....
19	Yes .....	15 minutes; 2-3 times	Lead .....	Yes * .....	.....
20	No .....	20 minutes; thrice ....	No .....	Recovery * .....	* .....
21	Yes .....	10 minutes; 1-7 times.	Lead .....	** .....	* .....
22	Yes .....	Varies * .....	Yes * .....	* .....	* .....
23	Yes .....	10-30 minutes; 1-6 times.	Lead .....	Yes * .....	* .....
24	.....	.....	.....	.....	.....
25	Yes * .....	10-15 minutes; thrice.	Tin-foil .....	Yes .....	* .....
26	Yes .....	5 minutes; 2-3 times ..	Lead-foil .....	Yes * .....	* .....
27	Yes .....	9 minutes * .....	Yes * .....	Necrosis; no .....	* .....
28	Yes .....	15 minutes; 3-6 times.	Tube shielded .....	Toxæmia; no * .....	Usually .....
29	Yes .....	5 minutes; thrice .....	Lead .....	* .....	.....
30	Yes .....	10 minutes; thrice ...	Lead and glass shield.	Slight erythema .....	* .....
31	Yes * .....	10-15 minutes; thrice.	Lead .....	* .....	* .....

# THERAPY—Continued.

## PLICATION.

### RÖNTGEN RAY DERMATITIS

What is your treatment for the acute and chronic forms of the above?

In the acute form, a non-irritating unguent, as lanolin, prevents incrustation and is strongly recommended. For deep, sloughing burns, clear up, and stimulate with the galvanic current. If rebellious to treatment, excise and skin graft.

This depends entirely on the severity of the dermatitis and the idiosyncrasy of the patient.

Discontinue treatment.

Dry heat. Simple ointments, sparingly. Salicylic collodion for scales; for ulcers, argyrol (20 to 30 per cent. solution); cover latter with silver-leaf.

I have none, nor do I know of any.

Lime-water, lanolin, lard, equal proportions (Dr. C. W. Allen's formula).

Avoidance of the X-ray atmosphere. For acute cases, Liquor Burorii and 15 per cent. boracic lanolin-suspension.\*

Never had any case of dermatitis to treat. Have nothing specially adapted to recommend.

Varies. If superficial and painful, I use liq. plumb. subacetat. dil.; much pain, lanolin with a trace of cocaine and surrounded by an oleaginous material on lint, the whole protected by absorbent cotton.

Acute: Cease treatment; allay itching with a saturated solution of sodium bicarbonate. Chronic: Cleanse with a saturated solution of potassium permanganate and apply plain sterile vaseline on sterile gauze.

For the acute form, a lead lotion. Have found nothing satisfactory for the chronic form.\*

Castor oil and Basham mixture.

Acute: Lanolin and picric acid. Chronic: Excision and skin grafting for ulceration. Lanolin in cases of parched condition, for circulation and cutaneous nutrition. High-frequency currents, for stimulation of the circulation, locally.

For the acute form, protection from air and mechanical injury.

The usual methods in vogue.

The lesion should be unexposed and be kept away from the rays. The application of a thick ointment of the oxide of zinc. The effluve from a high-frequency machine.

Stearate of zinc, with ichthyol 10 per cent., to prevent and allay dermatitis and itching. For chronic cases, sterile gauze and normal salt solution with orthoform for pain.

Paint the part with an aqueous solution of resorcin (25 per cent.), once daily. For itching, immerse in hot water, the hotter the better. In the chronic form, removal of the patient from X-ray influence for a year or eighteen months.

Cessation of irradiation. Lead lotion.

Lanolin.

Meet the symptoms as they arise, the same as you would in any other condition.

The treatment recommended is a lengthy one, and is described fully in the addendum (*vide*).

Discontinue X-ray therapy. Treat as any other burn. Avoid all irritating applications.

Olive oil, listerine, and bismuth subnitrate, equal parts of each.

Pain has been relieved, in a few instances, by an ointment composed of ten grains each of orthoform, resorcin, and calomel, in one ounce of cold cream.

No active treatment is recommended. Avoid the X-ray atmosphere. The operator is advised to remain in a room thirty feet from the tube, and to place himself behind an iron screen one-fourth of an inch in thickness.

Had no occasion to employ any.\*

Simple dry, or absorbent, aseptic dressings. Zinc oxide ointment.

Avoid active treatment. Zinc oxide to allay the itching.

Acute: Removal from the exciting cause; soothing and antiphlogistic drugs and preparations. Chronic: Avoid the rays, developing fluids, and cold water; apply hot water, bland unguents, and mild high-frequency currents. For deep Röntgen ulcers apply caroid to slough and treat as local gangrene.











# INDEX

In order to facilitate reference, the various diseases and their treatments are grouped under four headings,—X-rays in the treatment of, radium treatment of, high-frequency currents in, and electricity in diseases of. Thus, in studying the action of the Röntgen rays on acne, the reader will refer to X-rays in the treatment of acne. The very arbitrary and artificial division of the headings electricity (faradism, galvanism, static current, etc.) and high-frequency currents is simply an index convenience.

## A

<p>Abbe, his statistics on renal skiagraphy ..... 353  on radium strength and radium therapy ..... 507</p> <p>Abrams, on the causes of restriction of the diaphragmatic wave..... 310</p> <p>Accelerator, for photography..... 223</p> <p>Accessories to the static machine... 52</p> <p>Accumulators ..... 41</p> <p>Action of light on plants..... 511  of the X-rays on bacteria.. 389-394</p> <p>Acute X-ray dermatitis..... 400</p> <p>Adamson, on the X-ray treatment of ringworm..... 450</p> <p>Advantages of fluoroscopy..... 213  of print in skiagraphy..... 231  of stereo-skiagraphy..... 251  of X-rays in the differential diagnosis of complicated fractures ..... 257  in the treatment of trachoma ..... 487</p> <p>Albers-Schönberg, on the consumption of tubes..... 198  on the four degrees in vacuum tubes..... 195  on the likelihood of X-ray dermatitis..... 402  on sterility caused by the X-rays..... 412</p> <p>Alternating current..... 45</p> <p>Ampere ..... 37</p> <p>Ampere-hour, definition of..... 42</p>	<p>Analgasic action of the X-rays..... 493</p> <p>Anatomy, value of the X-rays in, 252-255</p> <p>Aneurisms, aortic, their diagnosis and differential diagnosis skiagraphically ..... 333-335</p> <p>Apostoli and Oudin, on the treatment of X-ray dermatitis..... 411</p> <p>Apparatus and method of X-ray therapy..... 420-427  used in dental skiagraphy..... 370</p> <p>Arm bath..... 79</p> <p>Arneth, on the blood-changes induced in leukæmia by the X-rays. .... 486</p> <p>Ascending current..... 67</p> <p>Ausset and Bedart, on the X-rays in tuberculous peritonitis..... 480</p> <p>Author's cases of cerebral skiagraphy. 281  of incipient pulmonary tuberculosis diagnosed by the X-rays..... 317, 318  of mammary carcinoma treated by the X-rays 465-467</p> <p>examining box..... 236</p> <p>head rest for cerebral skiagraphy 278</p> <p>method of irradiating cases of trachoma..... 487  cases of uterine cancer. 470</p> <p>of skiagraphing rectal imperforation..... 345</p> <p>of treatment of chronic X-ray dermatitis..... 409</p> <p>report on irradiation of cases of epilepsy..... 495, 496</p>
--	---

Author's table for skiagraphy, stereo-skiagraphy, and X-ray treatment.....	200, 248
tank.....	228
tube-holder.....	201
views in regard to the limitations and value of the X-rays in carcinoma.....	464, 465
Auto-conduction by the solenoid.....	147

## B

Bacteria, action of the X-rays on	389-395
Bactericidal action of radium.....	501
Bar and Boullé, on red light treatment of X-ray dermatitis.....	411
Barnum, on the X-ray treatment of keloid.....	490
Barrel's method for the localization of foreign bodies.....	300
Barthélemy and Oudin, on the X-rays in hypertrichosis.....	448
Batten, his method of treating ring-worm by irradiation.....	450
Bauer's vacuum tube.....	194
Beck, on microscopy of adeno-carcinoma after irradiation.....	418
on skiagraphy in hepatic conditions.....	348
osteoscope of.....	196
Becquerel, studies of, with radio-active substances.....	498, 499
Behavior of light on animals and man	512
Berton's experiments with the X-rays on the Klebs-Löffler bacillus.....	389
Bishop, on exophthalmic goitre.....	121
on X-ray treatment of trachoma	488
Blackening of the tube.....	197
Blackmar, on the action of the X-rays in malignant disease.....	417
Blondlot, R., on velocity of propagation of X-rays.....	167
Blue light as an anæsthetic.....	520
Boggs, on the X-rays in tuberculous adenitis.....	481
Boido and Boido, their reports of irradiation in cases of pulmonary tuberculosis.....	478
Bordier, on dermatitic changes caused by the X-rays.....	405
Box-cover for X-ray tubes.....	202
Branth, his method of irradiation in cases of epilepsy.....	496, 497

Brewster's refracting stereoscope for stereo-skiagraphy.....	249
Brown and Osgood, on sterility due to the X-rays.....	412, 413
Brush discharge.....	57
Bullitt, his comparison between the X-rays and the surgical treatment of tuberculosis.....	481
Bunsen cell.....	63
Burr, reports of cases by, on bony congenital deformities.....	275

## C

Caldwell and Simon's interrupter....	178
Caldwell's cavity vacuum tube.....	424
Campbell, on the radiotherapy of acne	452
Cannon's studies on the stomach during digestion as viewed fluoroscopically.....	342
Capp and Smith, on a review of the advancements made by irradiation in lymphatic leukæmia.....	485
Carabelli and Luraschi, on the X-rays in prostatic hypertrophy.....	492
Care of battery.....	64
of photographic plates.....	222
of static machine.....	51
of vacuum tube.....	196, 197
Catalysis.....	98
Cataphoresis.....	75
its bearing on galvanism.....	75
Cataphoric electrodes, for high-frequency currents.....	144, 145
Cathode rays, chemical and photographic effects of.....	159
deflection of.....	185
fluorescence and phosphorescence of.....	159
physiological effects of.....	159
production of.....	158, 185
radiability of.....	158
rectilinear propagation of... ..	187
reflection, refraction, and polarization of.....	159
theories to explain the existence of.....	159
Causes and prevention of faulty negatives.....	231
of X-ray dermatitis.....	398, 399
Cautery batteries.....	69
Cells, Bunsen.....	63
charging the.....	64

- Cells, galvanic ..... 62  
 "group" arrangement of..... 41  
 Grove..... 63  
 Leclanché..... 64  
 "parallel" arrangement of. . . 40, 63  
 "series" arrangement of..... 40, 63  
 types of..... 63  
 wet and dry..... 63  
 Central galvanization..... 69  
 pneumonia, value of the X-rays  
 in..... 320  
 C. G. S. system..... 36  
 Chain-holder for the static machine... 53  
 Changes induced in diseased tissues  
 by the X-rays..... 415-419  
 Chart of static modalities..... 60-61  
 Chemical and photographic effects of  
 radium..... 498, 499  
 Chromoradiometer of Bordier, for  
 measuring X-ray dosage..... 433  
 of Holzknacht, for measuring X-  
 ray dosage..... 432  
 Chronic X-ray dermatitis..... 400  
 Cinemato-radiographs of the heart... 329  
 Clark, on the therapeutic action of  
 the X-rays in cancer..... 471-473  
 Classification of radio-activity..... 501  
 of radium rays..... 501  
 Closure of the bladder, shown skia-  
 graphically..... 360  
 Codman, on fluoroscopy and skiagra-  
 phy in a study of joint mechan-  
 ism..... 254, 255  
 on latent stage of X-ray derma-  
 titis..... 401  
 on pathology of X-ray dermatitis 404  
 on relationship of static machines  
 and coils to X-ray dermatitis. 403  
 Coil. (*See* Induction coil.)  
 Coleman, on electricity in many oph-  
 thalmic affections..... 136, 137  
 Coley, conclusions of, on the value of  
 the X-rays in malignant disease... 476  
 Commutator..... 172  
 Compression diaphragm ..... 202  
 disadvantages of..... 203  
 Condenser..... 171  
 Condenser electrode..... 145  
 Conditions necessary for success by  
 Finsen's method..... 520  
 Conductive currents..... 58  
 Conductivity..... 38  
 Connal, on high-frequency currents  
 in dulness of hearing..... 154, 155  
 Connections of a galvanic battery... 62  
 Construction of induction coil..... 171  
 Continuous current..... 45  
 Contremoulins' measurement of X-  
 ray dosage..... 439  
 on the skiagraph in pelvime-  
 try..... 363-365  
 Convective currents..... 57  
 Cossar's cavity vacuum tubes..... 424  
 Coulomb..... 38  
 Courtade, radiometer of..... 438  
 Covell, on a case of asthma with  
 fibroids, cured by galvanism.... 126  
 Crookes, experiments on radio-active  
 substances..... 499  
 his assertion that matter is radi-  
 ant..... 157  
 spinthariscopes, for studying the  
 fluorescence of radium..... 500  
 tube..... 187  
 tube for therapeutics..... 422  
 (*See* Vacuum tube.)  
 Crypto-radiometer of Wehnelt, for  
 measuring X-ray dosage..... 431  
 Cryptoscope..... 199  
 examination with..... 211  
 Curie, Professor and Madame, on the  
 study of radio-activity..... 499, 500  
 Current going to the primary coil, in  
 the study of X-ray dosage..... 427
- ### D
- Dally, his classification of shadow  
 quality with percussion note.. 319  
 on pleurisy with effusion, studied  
 skiagraphically..... 322  
 Dark room in photography..... 221  
 D'Arsonval, on high-frequency cur-  
 rents..... 138, 141  
 Data on the negative in skiagraphy.. 218  
 Davidson, contact rotary interrupter  
 of..... 174  
 his method of localization of for-  
 eign bodies in the eye.... 295-297  
 Davies, experiments with the X-rays  
 on bacteria..... 389  
 X-ray study of gravid uteri... 366  
 Definitions of electro-therapeutic  
 terms..... 67  
 Degeneration of muscles..... 90



- Dermatitis. (*See* X-ray dermatitis.)
- Dermo or iron electrode lamp. . . . . 516
- Descending current. . . . . 67
- Destot's views on dermatitic changes caused by the X-rays. . . . . 405
- Developers in photographic work 222, 223
- Developing papers. . . . . 232
- Diagnosis and differential diagnosis of aortic aneurisms by the X-rays. . . . . 333-335
- Diaphragm (skiagraphic). . . . . 202
- compression. . . . . 202
- its disadvantages. . . . . 203
- lead iris. . . . . 221
- Differentiation between ordinary photograph and skiagraph. . . . . 214
- Disadvantages of compression diaphragms. . . . . 203
- of fluoroscopy. . . . . 214
- Disan's method of fluoroscopic examination of the normal heart. . . . . 324
- Disk interrupter. . . . . 174
- Disruptive currents. . . . . 58
- Distance of the tube, for X-ray treatment. . . . . 424
- from the plate. . . . . 219
- Dodging. . . . . 232
- Dorn, Professor E., on visibility of X-rays. . . . . 167
- Dosage of the galvanic current. . . . . 67
- of the static current. . . . . 56
- of the X-rays. . . . . 426, 427
- (*See* X-ray dosage.)
- Dry cells. . . . . 63
- Drying the negative. . . . . 228
- Du Bois-Reymond, his law for the electrical stimulation of muscles. . . . . 94
- on muscular contraction following electrical irritation of motor nerves. . . . . 92
- Ducretet's self-regulating tube. . . . . 192
- Dunham, selenium cell of, for X-ray dosage. . . . . 439
- Duration and course of X-ray dermatitis. . . . . 406, 407
- of exposure in irradiation. . . . . 425
- E**
- Eder and Valenta, on the degree of vacuum of tubes. . . . . 195
- Edsall, Pancoast, and Musser, on the asserted secondary results occurring after irradiating cases of leukemia 486
- Effects of light on bacteria. . . . . 511, 512
- of radium on the eye. . . . . 502
- on the nervous system. . . . . 502
- Effluve. . . . . 145
- Einhorn, his observations on radium therapy. . . . . 506
- on transillumination of the stomach. . . . . 341
- Electrical currents, effects of, on sensory cutaneous nerves 95
- on the abdominal organs. . . . . 97-98
- on the head. . . . . 97
- on the sensory nerves of muscles. . . . . 95
- on the skin. . . . . 97
- on the special senses. 95-96
- on the spinal cord. . . . . 97
- on the sympathetic system. . . . . 96
- pathological physiology of, in disease. . . . . 98
- douche bath. . . . . 79, 80
- energy, sources of. . . . . 39
- mains. . . . . 45
- reactions of nerves of special sense and of the sensory nerves. . . . . 91
- souffle. . . . . 58
- stimulation of muscles. . . . . 94
- wind. . . . . 58
- Electricity as a part of the medical curriculum. . . . . 31, 32
- for aneurism. . . . . 127-128
- historical sketch of the rise of. 29-31
- in cutaneous affections. . . . . 99-103
- in acne. . . . . 99
- in alopecia. . . . . 99
- in cutaneous anæsthesia. . . . . 101
- in eczema. . . . . 99
- in furuncles and carbuncles. . . . . 102
- in herpes zoster. . . . . 101
- in hypertrichosis. . . . . 100
- in moles and warts. . . . . 102
- in nevus. . . . . 102
- in port-wine mark. . . . . 102
- in prurigo. . . . . 101
- in pruritus. . . . . 99

- Electricity in cutaneous affections :  
 in psoriasis and pityriasis ..... 101  
 in ringworm and scleroderma..... 101  
 in diseases of the articular system..... 105-107  
 in chronic articular rheumatism ..... 105  
 in fibrous ankylosis.... 106  
 in gout..... 106  
 in hydro-arthritis..... 105  
 in rheumatoid arthritis 105  
 in synovitis..... 105  
 in tuberculous arthritis..... 106-107  
 in diseases of the digestive system..... 107-111  
 in constipation..... 108  
 in dilatation of the stomach..... 107  
 in enteritis..... 109  
 in fissure of the anus.. 110  
 in hemorrhoids..... 111  
 in nervous dyspepsia... 108  
 in prolapse of the rectum..... 110-111  
 in stricture of the rectum..... 111  
 in vomiting..... 107  
 in diseases of the genito-urinary system..... 111-116  
 in impotence..... 116  
 in incontinence of urine 115  
 in nephritis..... 116  
 in orchitis..... 116  
 in paralysis of the urinary bladder..... 114  
 in prostatitis..... 113-114  
 in spermatorrhœa.... 115  
 in stricture of the male urethra..... 111-112  
 in diseases of the nervous system..... 116-122  
 in cephalalgia..... 117  
 in chronic spinal muscular atrophy..... 119  
 in epilepsy..... 119  
 in exophthalmic goitre. 120  
 in hemiplegia..... 118  
 in hypochondriasis and melancholia..... 120
- Electricity in diseases of the nervous system: in hysteria.. 120  
 in insanity..... 120  
 in insomnia..... 119  
 in locomotor ataxia... 119  
 in neuralgia..... 116-117  
 in neurasthenia ..... 120  
 in paralysis, from arsenic, etc..... 118  
 from rheumatism.. 118  
 from syphilis..... 118  
 in paraplegia..... 118  
 in peripheral neuralgia. 118  
 in poliomyelitis..... 119  
 in sciatica..... 118  
 in tic douloureux..... 117  
 in gynæcology..... 122-127  
 in amenorrhœa..... 124  
 in chronic metritis..... 125  
 in dysmenorrhœa..... 124  
 in fibroid tumors..... 124  
 in ovarian tumors..... 124  
 in periuterine hæmatocele.. 125  
 in post-partum hemorrhage. 125  
 in slow labor..... 126  
 in stenosis of the cervical canal..... 125  
 in subinvolution and atrophy..... 125  
 in urethral caruncle..... 125  
 in vomiting of pregnancy.. 126  
 in muscular affections..... 103-105  
 in muscular contrac-  
 tures..... 104  
 in myalgia..... 103  
 in myasthenia gravis.. 105  
 in secondary hemiplegic contractures..... 104  
 in torticollis..... 104  
 in writers' cramps. 103-104  
 in ophthalmology..... 134-137  
 in blepharospasm..... 134  
 in cataract..... 135  
 in diseases of the lacrymal canal..... 135  
 in oculo-motor paralysis.. 134  
 in retinal anæsthesia..... 135  
 in various ophthalmic affections (a summary).. 136, 137  
 in otology..... 131-134  
 in chronic suppuration of the middle ear..... 131

- Electricity in otology: in deafness of  
 auditory nerve origin 131  
 of hysterical origin... 134  
 in otalgia of neuralgic origin 134  
 in pruritus of the auricular  
 canal..... 134  
 in stricture of the eustachian  
 tube..... 134  
 in tinnitus aurium. . 132, 133, 134  
 in rhinology and laryngology 129-131  
 in anæsthesia of the  
 pharynx..... 130  
 in anosmia..... 130  
 in asthma..... 131  
 in atrophic pharyngi-  
 tis..... 130  
 in atrophic rhinitis.... 129  
 in laryngeal fatigue.... 130  
 in ozæna..... 129  
 in pharyngitis..... 129  
 nature and properties..... 34
- Electrodes, for cataphoresis, with  
 high-frequency currents. . 144, 145  
 for galvanic battery..... 66  
 for laryngology and rhinology.. 129  
 for prostatic hypertrophy..... 113  
 for static applications..... 52  
 glass vacuum, for high-frequency  
 currents..... 143, 144
- Electro-diagnosis, hints for practical  
 testing in..... 89  
 rules to be followed in.... 81
- Electrolytic interrupters ..... 175-178
- Electro-magnetic or "absolute" C. G.  
 S. units..... 37
- Electro-magnets..... 34
- Electro-motive force..... 37  
 of the static machine... 52
- Electro-physiology..... 92
- Electro-static units..... 36
- Electro-therapeutic terms, definitions  
 of..... 67
- Electrotonus..... 94
- Ellis, on tissue changes due to the X-  
 rays..... 418
- Envelo developer..... 227
- Erb's method with electrical applica-  
 tions in epilepsy..... 119
- Essential features of Crookes' vacuum  
 tube..... 188
- Evolution of the X-rays..... 156, 157
- Examinations with the cryptoscope.. 211
- Exner, on the mode of retrogression  
 of cancer metastases under radium  
 therapy..... 504
- Explosion of the tube..... 198
- Extra-oral method in dental skiag-  
 raphy..... 371
- ### F
- Factors varying the time of X-ray  
 exposure..... 220
- Farad..... 38
- Faraday's laws..... 169
- Faradic current, as a diagnostic agent 74  
 as a therapeutic agent..... 74  
 method of application..... 73
- Ferguson, on the radiotherapy of  
 mammary carcinoma..... 469
- Ferris, on the X-ray treatment of pso-  
 riasis..... 457
- Filters, as prophylaxis against X-ray  
 dermatitis..... 407  
 for X-ray work..... 426
- Finsen, his experiments with light on  
 acquired pigmen-  
 tations..... 513  
 with red light. .... 517, 518  
 method of, with concentrated arc  
 light..... 515, 516  
 treatment of smallpox..... 519
- Fixing..... 227  
 bath, acid chrome..... 227
- Fluorescence, its application in dis-  
 ease..... 442, 443  
 its natural and artificial produc-  
 tion in the human body..... 441  
 of radium..... 500  
 of the screen, for measuring X-  
 ray dosage..... 440  
 of the tube and appearance of the  
 electrodes for measuring X-  
 ray dosage..... 440
- Fluorometer of Williams, for measur-  
 ing X-ray dosage..... 438
- Fluoroscope..... 199  
 method of examination with... 210
- Fluoroscopic examination of biliary  
 calculi..... 346-348  
 of costal angle..... 309  
 of diaphragm, in health and  
 disease..... 308, 310, 311  
 of heart.. 308, 311, 325, 329, 332  
 of liver..... 346



- Fluoroscopic examination of lungs 306, 308  
of spleen..... 348, 349  
of stomach..... 338-341  
(See Skiagraphy and the X-rays  
in the treatment of various  
diseases.)
- Fluoroscopy..... 210  
advantages of..... 213  
disadvantages of..... 214  
positions of the tube and patient  
for..... 212, 213  
preparation of the patient for.... 211  
size, shape, and intensity of the  
image in..... 213
- Foreign bodies and their localization. 285  
in the eye..... 289  
in the genito-urinary tract.. 288  
in the intestines..... 288  
in the larynx, trachea, and  
bronchi..... 288  
in the œsophagus..... 287  
in the stomach..... 288  
their localization by Barrel's  
method..... 300  
by Davidson's method  
295-297  
by Fox's method..... 298  
by Grashey's method  
303-305  
by Grossman's method  
297, 298  
by Harrison's method.. 302  
by Leonard's method.. 302  
by punctograph..... 299  
by Rémy's method.... 300  
by screen method..... 299  
by Shenton's method.. 301  
by Sweet's method 290-295  
by triangulation method 303
- Fox, his method of localizing foreign  
bodies in the eye..... 298  
on the treatment of retinal anæsthesia  
by voltaic alternatives.. 135
- Fractures and dislocations. (See X-rays  
as a diagnostic agent.)
- Franklin, his views on the ionization  
of confined gases for use in X-ray  
dosage..... 436
- Frequency of X-ray exposure..... 426
- Freund, on dangers of X-ray therapy 403  
on fever production in X-ray  
dermatitis..... 405
- Freund, on hypertrichosis..... 447  
on lupus vulgaris..... 444  
radiometer of..... 435  
X-ray action on diseased tissue.. 416
- Friedlander's interrupter..... 177
- G**
- Galvanic battery..... 62  
care of..... 64  
charging the cells of..... 64  
connections of..... 62  
polarity of..... 64  
(See Cells.)  
current..... 39  
dosage of..... 67
- Galvanism..... 62
- Galvano-faradic box..... 67
- Galvano-faradization..... 69
- Galvanometer..... 66
- Gassiot, experiments of, with the  
Ruhmkorff coil instead of cells... 156
- Gassmann, on blood-vessel changes  
due to the X-rays..... 397
- Gassmann and Schenkel, on dermati-  
tis due to the X-rays..... 396
- Geissler, Heinrich, on glow discharges 156
- General reduction of the negative.... 230
- Geyser, on X-ray treatment of tra-  
choma..... 488
- Gilechrist, remarks of, on dermatitic  
areas due to the X-rays..... 395
- Gill, on cataphoresis..... 75-77
- Glass, plates of, for static machines.. 52  
vacuum electrodes, for high-fre-  
quency currents..... 143, 144
- Gocht, the form of the ray-emitting  
area of anti-cathode..... 219
- Griffith, on electricity in the treat-  
ment of aneurisms..... 127
- Grisson's resonator..... 185
- Grossman's method of localization of  
foreign bodies in the eye..... 297-298
- Ground glass substitute..... 232
- "Group" arrangement of cells..... 41
- Grouven, on X-ray action on diseased  
tissue..... 416
- Grove's cell..... 63
- Grubbe, on the X-rays in tuberculous  
adenitis..... 481
- Guilleminot, his instrument for cine-  
mato-radiographs..... 329

- Guilleminot, on the measurement of the costal angle..... 309
- Guilleminot-Courtade method of measuring X-ray dosage..... 438
- H**
- Hahn, on the radiotherapy of eczema 451
- Halberstaedter, on sterility caused by the X-rays..... 412
- Hallepeau and Gadaud, on the sclerogenic action of the X-rays..... 417
- Hard tubes..... 195
- Hardening the negative..... 229
- Hare, on electricity in aneurisms.... 128
- Haret, on the X-ray treatment of neuralgia..... 494
- Harris, Sir W. Snow, on spark length. 156
- Harrison's method for the localization of foreign bodies..... 302
- Hartigan, on radium therapy of carcinoma..... 509  
of naevus..... 507
- Heliotropism..... 511
- Hemmeter's method in skiagraphy of the stomach..... 340
- Henry, the, as an electrical unit.... 38
- Herringham, on the brachial plexus in the new-born..... 88, 89
- Hertz, on high-vacua discharges.... 157  
resonator of..... 146
- Heüman, on exophthalmic goitre.... 122
- Hewitt, Cooper, mercury vapor lamp of..... 516, 517
- High-frequency currents..... 138-155  
apparatus for..... 139, 140  
D'Arsonval's..... 141  
Morton's..... 140  
Tesla's..... 142  
electrodes for..... 143-145  
history of..... 138  
methods of application of  
146-148  
auto-condensation.... 148  
direct application.. 146, 147  
indirect application.. 147  
local application..... 148  
Oudin resonator for..... 143  
physical properties of.. 145, 146  
dynamic effects..... 145  
electro-static effects... 145  
induction effects..... 145  
resonance effects..... 146
- High-frequency currents, physiological properties of.... 148, 149  
treatment by, in colitis.... 152  
in dulness of hearing..... 154, 155  
in epilepsy..... 153  
in gonorrhœa..... 155  
in gout..... 150  
in hysteria..... 151  
in lupus vulgaris..... 151  
in obesity..... 150  
in ozæna..... 152  
in piles, rectal fissure, and pruritus ani... 151  
in rheumatism..... 150  
in rodent ulcer and malignant disease..... 151  
in skin diseases..... 154  
in trachoma..... 154  
in tuberculosis..... 149
- Hillard, on blue light as an anæsthetic 521
- Hint in using coil and interrupter in X-ray therapy..... 420, 421
- Hints for practical testing in electrodiagnosis..... 89
- Hirschmann's monopol tube..... 194
- Hirst, on the limitations of galvanism and faradism in gynæcology..... 122
- Histological changes induced by the action of the X-rays..... 395-398
- Historical sketch of the rise of electricity..... 29-31
- History taking in skiagraphy..... 216
- Hoffa, on the probability of X-ray dermatitis..... 402
- Hoffman's measuring stand and examining frame..... 200
- Holland, on skiagraphing a case of biliary calculi..... 347
- Holtz' influence machine..... 49
- Holzknicht and Bécèle, on the oblique method of examination of aneurisms..... 334
- Holzknicht and Brauner's technic in gastric skiagraphy..... 340
- How to view the X-ray negative.... 234
- Hultz, on skiagraphy of the stomach. 340
- Huntington, on the pathological physiology of X-ray dermatitis..... 404
- Hyde, Montgomery, and Ormsby, on radiotherapy in acne rosacea.... 454  
in psoriasis..... 456

- Hydraulic analogy, illustrating potential..... 34
- Hydro-electric bath..... 77, 78
- I**
- Idiosyncrasy to static current..... 55
- Immobilization of part in skiagraphy. 217
- Improvement of the negative..... 229
- Independent vibrating hammer interrupter..... 172
- Induction coil..... 169
- construction of..... 171
- GaiFFE..... 184
- Grisson..... 184
- Kinraide..... 181-183
- Tesla..... 180
- variable primary ("jumbo")
- 178, 179
- without interrupter..... 184
- Induction, laws of..... 169
- mechanism of..... 170
- principles of..... 71
- Influence machine..... 46
- of Holtz..... 49
- of Voss or Toepler..... 50
- of Wimshurst..... 47
- (See Static machine.)
- Influence of electricity on motor nerves and on muscles..... 92
- of photodynamic substances on the action of the X-rays..... 443
- of radium on agglutination..... 502
- Installation of X-ray apparatus and the management of its various parts..... 204-207
- Intensifying screens..... 220
- Interpretation of X-ray negatives.... 234
- Interrupted insulation..... 57
- Interrupter..... 73
- electrolytic..... 175
- Caldwell and Simon's..... 178
- Friedlander's..... 177
- Wehnelt's..... 175, 176
- mechanical..... 172
- Davidson's rotary contact-breaker..... 174
- disk..... 174
- independent vibrating hammer..... 172
- jet..... 175
- Johnston's..... 174
- platinum..... 172
- Interrupter, mechanical, self-starting 173
- Vril..... 173
- Intra-oral method in dental skiagraphy..... 370
- Ionization method of measuring X-ray dosage..... 436
- J**
- Jagn, on the influence of radium on agglutination..... 502
- Jameson, on the radiotherapy of xeroderma pigmentosum..... 455
- Jaumann's theories of the cathode rays..... 159
- Jet interrupter..... 175
- Johnston, mercury interrupter of.... 174
- on fluorescence of screen as a measurement for X-ray dosage 440
- on keratoses, the result of X-ray dermatitis..... 406
- Jones, on the probable physiological action of high-frequency currents.. 148
- Joule..... 38
- Jutassy, on the X-rays in hypertrichosis..... 447, 448
- K**
- Kaposi's views on dermatitic changes caused by the X-rays..... 405
- Keen's experiments with the X-rays on bacteria..... 389
- Kibbe, on the histological changes in the skin due to the X-rays..... 395
- Kienböck, his classification of the degrees of vacuum... 196
- of X-ray dermatitis... 401
- his experience with the X-rays in sarcoma..... 475
- quantimeter of..... 434
- Kienböck and Benedikt, on the X-rays in cerebral affections..... 280
- Köhler, his thermometric method for X-ray dosage..... 441
- Koethe, on the influence of photodynamic substances on the action of the X-rays..... 443
- Krause, on the skiagraphic examination of the heart..... 332
- Kummel and Rumpel's conclusions on renal skiagraphy..... 354



- | L  | M   |
|--|---|
| Labile applications..... 67-68   | McGuire, on the value of radiotherapy<br>in varicose veins..... 457                 |
| Lacaille's apparatus for measuring X-<br>ray dosage..... 430   | Macintyre, on the X-rays in rhinology 367   |
| Latent stage of X-ray dermatitis..... 401  | Magnetic units..... 36  |
| Laws of Faraday..... 169   | Magnetism, nature and properties of. 33   |
| of induction..... 169  | Manders, on radio-active medication<br>of rheumatism..... 509                       |
| Lead iris diaphragm..... 221   | on the X-rays in epilepsy..... 496  |
| Leclanché's cell..... 64   | Marie and Ribaut, their formulæ and<br>table for stereo-skiagraphy.... 246, 247     |
| Ledue, on the electrolytic introduc-<br>tion of salicylic ions in cases of<br>neuralgia ..... 117              | Marx, E., on velocity of the X-rays.. 168   |
| Lenard, on the properties of cathode<br>rays..... 157  | Massey, "The Apostoli Treatment of<br>Fibroids"..... 77                             |
| Leonard, his double-focus-tube<br>method for localization..... 302   | Matignon, Maj., on the X-rays in war. 286   |
| his prophylaxis against X-ray<br>dermatitis..... 407   | Maxwell, Clerk, on the electro-mag-<br>netic theory of light..... 156               |
| on renal skiagraphy..... 353   | Mayo, on the value of the X-rays in<br>exophthalmic goitre..... 490                 |
| on the analgesic action of the X-<br>rays in neuralgia..... 493, 494   | Mechanical interrupters..... 172-175<br>regeneration of vacuum tubes... 194         |
| views of, concerning X-ray in-<br>fluence on diseased tissue... 416  | Mechanism of induction..... 170   |
| Leukowitsch's ophthalmological ex-<br>periments in locating foreign bod-<br>ies..... 289                       | Medical and surgical affections of the<br>kidney, studied skiagraphically.... 351   |
| Leven and Barret, on a study of the<br>outlines of the stomach with the<br>fluoroscope..... 343                | Medical induction coil..... 71-72   |
| Levy, R., selenium photometer of. ... 439  | Medico-legal aspect of the X-rays, in<br>relation to ossification and age 380       |
| Levy-Dorn's orthodiagraph..... 328   | aspect of X-ray sterility. ... 387, 388   |
| Leyden jar ..... 52  | considerations of the X-rays 375-388  |
| "Life" of the tube..... 198  | questions bearing on the X-<br>rays..... 379, 380                                   |
| Light, action of, on bacteria.... 511, 512   | Medium tubes..... 195   |
| on man..... 512  | Methods of measuring X-ray dosage.. 427<br>(See X-ray dosage, measure-<br>ment of.) |
| on plants..... 511   | of viewing stereo-skiagrams.... 249   |
| for photography..... 221   | Meyer and Eisenreich, on the X-ray<br>treatment of leukæmia..... 483                |
| nature of..... 510, 511  | Mica plates for static machines..... 52   |
| therapeutic action of..... 513   | Military surgery, X-rays in..... 285, 286   |
| treatment by artificial..... 514-521   | Milliamperage of the secondary in-<br>duced current, in X-ray dosage 427-429        |
| by blue..... 520, 521  | Milliamperemeter..... 66  |
| by natural..... 514  | Mills' views concerning the electrical<br>treatment of neurasthenia..... 120        |
| by red..... 517-520  | Minek and Gocht, on the action of X-<br>rays on typhoid bacilli..... 390            |
| Light-therapy among the ancients... 513  | Minin's views on the anæsthetic effect<br>of colored light..... 520                 |
| Liver, fluoroscopic examination of... 346  | Modes of application of static current. 57  |
| Local reduction of the negative..... 230   | Modus operandi of photographic de-<br>velopment..... 224-226                        |
| Localized faradization..... 74   |   |
| Lossen and Morawitz, on the clinical<br>and histological findings in leukæ-<br>mia, after irradiation..... 486 |   |
| Lovett and Brown, on X-rays in cox-<br>algia..... 283  |   |

- Monopolar bath..... 79  
 Moritz, orthodiagraph of..... 325-328  
   table of, showing the relation between the size of the heart and stature..... 330  
   views of, on orthodiagraphy in acute cardiac dilatation..... 331  
 Morton, "static induced current" high-frequency apparatus of.. 140  
   value of fluorescence artificially produced in the human body..... 442, 443  
   wave current of..... 58, 59  
 Moscowicz, on the X-ray treatment of prostatic hypertrophy..... 492  
 Motor points..... 81  
   in the chest and abdomen.. 87  
   in the face..... 85  
   in the lower limb..... 85  
   in the neck..... 85-87  
   in the upper limb..... 82-85  
 Mounting of photographs..... 233  
 Muffler, for the static machine..... 54  
 Müller's regulation tube..... 192  
 Musham, on the X-rays in general and localized tuberculosis..... 390
- N**
- Nature of light..... 510, 511  
   of radium emanations..... 501  
 Negative. (*See* Photographic negatives.)  
 Nerves of special sense, electrical reaction of..... 91  
 New radiometer of Freund, for measuring X-ray dosage..... 435  
 Newcomet's device for simultaneous treatment with the X-rays..... 424  
 Newcomet and Krall, on the X-ray treatment of a case of trachoma... 488
- O**
- Occurrence of radium in nature..... 498  
 Ohm..... 37  
 Ohm's law..... 39  
 Orthodiagraph of Levy-Dorn..... 328  
   of Morwitz..... 325-328  
 Orthodiagraphic localizer of  
   Grashey..... 303-305  
 Osmosis regulating tube..... 194  
 Osteoscope of Beck..... 196  
 Oudin, resonator of..... 143, 148  
 Oudin, Barthélemy, and Darier, on alopecia due to the X-rays..... 396  
   on cutaneous changes due to the X-rays.. 405
- P**
- Pancoast, on the X-rays in tuberculosis..... 479, 480  
 "Parallel" arrangement of cells... 40, 63  
 Pardo, on X-ray treatment of trachoma..... 488  
 Partial reaction of degeneration.... 91  
 Pathological physiology of electric currents in disease..... 98  
   of X-ray dermatitis..... 404  
 Pearce, on "Epiphenomena of Cerebral Hemorrhage"..... 281  
 Pelvimetry, as studied by the X-rays..... 362-367  
 Penetrability of urinary calculi by the X-rays..... 350  
 Penetration method of studying X-ray dosage..... 429  
 Penetration of radium..... 500  
 Pennington, on irradiations for pruritus ani..... 455  
 Permeability of the X-rays..... 287  
 Pfahler, on cerebral skiagraphy..... 279  
   on value of X-rays in tuberculosis..... 479  
 Pfahler and Schamberg, on X-ray filters..... 426  
 Pfüger's laws of contraction..... 92-93  
 Philipp, on X-ray sterility..... 413  
 Phillips, radio-active standard of... 437  
 Photographic negatives, drying of... 228  
   faulty, causes and prevention of..... 231  
   general reduction of..... 230  
   hardening of..... 229  
   improvement of..... 229  
   local reduction of..... 230  
   stains and spots on..... 231  
   washing of..... 228  
   (*See* X-ray negatives.)  
 Photography, accelerating solutions employed in..... 223  
   author's tank for..... 228  
   dark room for..... 221  
   developers employed in.... 222, 223  
   developing papers for..... 232

- Photography, dodging in..... 232  
 Envelo developer for..... 227  
 fixing in..... 227  
 fixing bath, acid chrome for... 227  
 ground-glass substitute in..... 232  
 light employed in..... 221  
 modus operandi of development  
 in..... 224-226  
 mounting in..... 233  
 plates, care of the, in..... 222  
 positives in..... 233  
 printing, toning, and mounting  
 in..... 231  
 reducers employed in..... 222  
 restraining solution used in..... 224  
 rules in handling developers for. 227  
 sensitive plates and films in... 222  
 tank development in..... 226  
 toning process in..... 233  
 transparencies and lantern slides  
 in..... 234
- Photometric methods of measuring  
 X-ray dosage..... 438
- Phototherapy..... 510-521
- Physical properties of radium..... 500
- Physician's responsibility in cases of  
 X-ray burns..... 382-387
- Physico-chemical method for measur-  
 ing X-ray dosage..... 431
- Physiological action of radium..... 502
- Physiology, uses of X-rays in... 255, 256
- Piffard, his principle of ionization for  
 X-ray dosage..... 437
- Plastographic method in stereo-ski-  
 agraphy..... 250
- Plates for skiagraphy, preparation,  
 size, protection, etc., of..... 217, 218
- Platinum interrupter..... 172
- Polar method of examination in elec-  
 tro-physiology..... 93
- Polarity and connections of the X-ray  
 tube..... 207, 208  
 of the battery..... 64  
 of the static current..... 54
- Porter, on the degree of vacuum of  
 tubes..... 195
- Position of the tube and patient in  
 fluoroscopic examinations. 212, 213  
 of the vacuum tube for therapeu-  
 sis..... 424
- Positives in photography..... 233
- Potential, theory of..... 34
- Precipitation test, for measuring X-  
 ray dosage..... 436
- Preparation of the patient for screen  
 examinations..... 211  
 for skiagraphic exami-  
 nations..... 216  
 for static treatment... 54
- Preutz, on skiagraphy of hepatic ab-  
 scess..... 278
- Prevention of the secondary or Sag-  
 nac rays..... 220
- Preventive measures against X-ray  
 dermatitis..... 407
- Principles of induction..... 71
- Printing, toning, and mounting..... 231
- Prostatic calculi, X-ray examination  
 of..... 360
- Protection of healthy parts during  
 irradiation..... 422, 423  
 of operator against X-ray derm-  
 atitis..... 407, 408
- Punctograph for the localization of  
 foreign bodies..... 299
- Puncture of the anti-cathode..... 198
- Pusey, on the radiotherapy of œsoph-  
 ageal carcinoma..... 469
- Pyelography..... 358
- Q**
- Quality of the X-rays..... 195, 220
- Quantimeter of Kienböck, for measur-  
 ing X-ray dosage..... 434
- Queirel and Acquavita, on the evolu-  
 tion of the osseous system skia-  
 graphically studied..... 366
- R**
- Radio-active standard of Phillips, for  
 measuring X-ray dosage..... 437
- Radiochromometer of Benoist, for  
 X-ray dosage..... 429
- Radiometer of Courtade, for measur-  
 ing X-ray dosage..... 438  
 of Freund, for measuring X-ray  
 dosage..... 435  
 of Sabouraud and Noiré..... 432
- Radium, bactericidal action of..... 501  
 chemical and photographic ef-  
 fects of..... 498-500  
 effects of, on the eye..... 502  
 on the nervous system.... 502  
 fluorescence and luminosity of.. 500



- Radium, influence of, on agglutination..... 502  
 occurrence of..... 498  
 penetrating power of..... 500  
 physical properties of..... 500  
 physiological action of..... 502  
 theoretical considerations concerning..... 501
- Radium treatment of cutaneous diseases..... 503-506  
 of exophthalmic goitre..... 507  
 of nævus..... 507  
 of rabies..... 507
- Ransom, on the X-rays in the treatment of tuberculosis..... 479
- Reaction of degeneration..... 90
- Reid, on a new method in renal skiagraphy..... 357
- Remote and indirect action of the X-rays..... 412
- Rémy's method for the localization of foreign bodies..... 300
- Renal skiagraphy..... 352-355
- Reports of scientists on the results of Finsen's method in smallpox..... 519
- Repumping the vacuum tube..... 198
- Resonance, as a factor in high-frequency studies..... 146
- Resonator, Grisson's..... 185  
 Hertz's..... 146  
 Oudin's..... 143, 146, 148
- Restraining solution..... 224
- Rheostat..... 66
- Rheotome..... 73
- Richardson, on "Electricity in Otology"..... 132-134
- Rieder, action of the X-rays on bacteria..... 390, 392, 393  
 technic of, in gastric skiagraphy. 340
- Rinchart, on the necessity of producing an X-ray dermatitis for the cure of disease..... 417
- Rockwell, on the relation between galvanism and cataphoresis... 75  
 on the treatment of suppuration of the middle ear by the galvanic current..... 131
- Röntgen, Professor, his discovery of the X-rays..... 157  
 sketch of the life of.... 157, 158
- Röntgen apparatus. (*See* X-ray apparatus.)
- Röntgen rays. (*See* X-rays.)  
 therapeutics. (*See* X-rays in treatment, etc.)
- Rudis-Jicinsky, on the destructive action of the X-rays on bacteria..... 393  
 on the X-rays in intestinal obstruction..... 345

## S

- Sabouraud, on the X-ray treatment of ringworm..... 450
- Sabrazés and Riviére, on the action of the X-rays on the bacillus prodigiosus..... 391
- Salomonson, on the measurement of X-ray dosage..... 428
- Sarcoma, its treatment by the X-rays..... 473-477
- Sayen's self-regulating tube..... 190
- Scheppegrell, on the radiotherapy of laryngeal carcinoma..... 470
- Schiff and Freund, on the X-rays in hypertrichosis..... 448
- Schnée's battery for hydro-electrotherapy..... 80
- Scholtz, on changes induced in diseased tissues by the X-rays..... 415, 416  
 on dermatitic changes due to the X-rays..... 397
- Schultze and Beck, on the action of X-rays on bacteria..... 390
- Schwartz, precipitation test for measuring the strength of the X-rays... 436
- Screen method for the localization of foreign bodies..... 299  
 (*See* Fluoroscope.)
- Secondary batteries..... 41  
 or Sagnac rays, prevention of... 220
- Selection and installation of X-ray apparatus..... 203-207
- Selenium photometer for measuring X-ray dosage..... 439
- Self-regulating and regenerative vacuum tubes..... 189
- Self-starting interrupter..... 173
- Senn, on the X-ray treatment of leucæmia..... 483
- Sensitive plates and films..... 222
- Sensory system, electrical reactions of 91

- Sequeira, on the telangiectases in dermatitic X-ray areas. . . . . 406
- "Series" arrangement of cells. . . . . 40, 63
- Sharp, on the thorium treatment of tuberculosis. . . . . 508
- Shenton, method of, for the localization of foreign bodies. . . . . 301  
on fluoroscopy for ureteral calculi. . . . . 356
- Shober's radiode for radium therapy. . . . . 506, 509
- Shoemaker, G. E., a study of the X-rays in a case of sarcoma of the abdominal wall. . . . . 474
- Shoemaker, J. V., his electrode for prostatic hypertrophy. . . . . 113
- Silbergleit, on cardiac (lateral) displacement. . . . . 329
- Sinusoidal current. . . . . 69
- Size, shape, and intensity of image on the screen. . . . . 213
- Sjörge and Sederholm, on the reaction of blondes and brunettes to the X-rays. . . . . 402
- Sketch of the life of Wilhelm Conrad Röntgen. . . . . 157, 158
- Skiagraph, differentiation between it and an ordinary photograph. . . . . 214
- Skiagrapher's preparation for court. . . . . 378
- Skiagraphic table. . . . . 200
- Skiagraphy. . . . . 214-218  
advantages of the print in. . . . . 231  
data on the negative in. . . . . 218  
immobilization of the part for. . . . . 217  
plates, preparation, size, etc., for. . . . . 217  
position of the Crookes tube in. . . . . 216, 219  
of the plate for. . . . . 216  
preparation of the patient for. . . . . 216  
synonyms for the word. . . . . 214  
(See X-ray diagnosis and treatment; also Fluoroscopy.)
- Skiameters and penetrometers for measuring X-ray dosage. . . . . 431
- Skinner, on radiotherapy of a sarcoma of the abdominal wall. . . . . 475
- Snow, on the electrical treatment of neurasthenia. . . . . 121
- Soddy, on the relative values of radium and thorium therapy. . . . . 502
- Soft, medium, and hard tubes. . . . . 195, 422
- Solenoid, auto-conduction by. . . . . 147
- Sormani, on the action of the X-rays on bacteria. . . . . 390
- Sources of electrical energy. . . . . 39
- Spintermeter for measuring X-ray dosage. . . . . 429
- Spinthariscopes for studying the fluorescence of radium. . . . . 500
- Sprengel, Hermann, invention of mercury air-pump. . . . . 157
- Stabile applications. . . . . 67, 68
- Stains and spots on the negative. . . . . 231
- Starr, on the relation of nerve roots to muscles. . . . . 87-88
- Static current, dosage of. . . . . 56  
idiosyncrasy to. . . . . 55  
modes of application of. . . . . 57  
polarity of. . . . . 54  
preparation of the patient for. . . . . 54  
machine. (See Influence machine.) . . . . . 46  
accessories to. . . . . 52  
advantages of, for X-ray work. . . . . 208  
care and manipulation of. . . . . 51  
disadvantages for X-ray work. . . . . 208  
electro-motive force of. . . . . 52  
glass plates for. . . . . 52  
mica plates for. . . . . 52  
principles of. . . . . 46  
theory of action of. . . . . 48  
(For the various forms of static current, see Static current, modes of application of.)  
modalities, chart of. . . . . 60-61
- Stationary vacuum tubes. . . . . 189
- Steinwand, on X-ray treatment of a case of pseudo-leukæmia. . . . . 483-485
- Stephenson and Walsh, on the X-ray treatment of trachoma. . . . . 487
- Stereo-fluoroscopy. . . . . 243  
and skiagraphy, history and principles of. . . . . 242
- Stereoscopic method for the localization of foreign bodies. . . . . 303
- Stereo-skiagraphy, advantages of. . . . . 251  
author's table for rearranging negatives for. . . . . 248  
Brewster's refracting stereoscope for. . . . . 249

- Stereo-skiagraphy, history and principles of . . . . . 242, 243  
 methods of viewing in . . . . . 249  
 plastographic method in . . . . . 250  
 technic of . . . . . 244-249  
 Wheatstone's reflecting  
 stereoscope for . . . . . 249
- Sterility caused by the X-rays . . . . . 412-414
- Stern, on localizing foreign bodies in the eye . . . . . 289
- Stokes, Sir G. G., on the probable nature of X-rays . . . . . 164, 165, 166
- Stomach, behavior of, during digestion, as seen by the X-rays . . . . . 342  
 fluoroscopic examination of, by  
 bismuth subnitrate . . . . . 338  
 by gaseous distention . . . . . 337  
 by mechanical means . . . . . 337  
 by transillumination . . . . . 341  
 position of, as seen by the X-rays . . . . . 342  
 skiagraphic examination of . . . . . 338  
 time of exposure in . . . . . 339  
 transillumination method in . . . . . 341
- Storage battery . . . . . 41  
 capacity of . . . . . 41  
 care of . . . . . 41  
 charging of . . . . . 41, 45
- Stover, on irradiations in cases of kraurosis vulvæ . . . . . 458
- Swain's study on the penetrability of urinary calculi . . . . . 350, 351
- Sweet, method of, for localization of foreign bodies in the eye . . . . . 290-295  
 on the analgesic action of the X-rays . . . . . 493
- Synonyms for the word "skiagraphy" . . . . . 214
- T**
- Table, skiagraphic . . . . . 200  
 author's . . . . . 200
- Tank or slow developing photographic process . . . . . 226
- Taylor, on the medico-legal aspect of the X-rays . . . . . 379
- Technic of dental skiagraphy . . . . . 370  
 of medico-legal skiagraphy . . . . . 377, 378  
 of renal skiagraphy . . . . . 352  
 (For detail of technic, see X-ray diagnosis; X-rays as a diagnostic agent; X-rays in the treatment of.)
- Tenny, on the X-rays in cases of ureteral calculi . . . . . 355
- Tesla, high-frequency apparatus of . . . . . 142  
 his experiments with high-frequency currents . . . . . 139  
 oscillator of . . . . . 181-183
- Theory of potential . . . . . 34
- Thermometric method for measuring X-ray dosage . . . . . 441
- Thomson, J. J., on radiant matter . . . . . 157
- Thomson, Sir William (Lord Kelvin)  
 on the relation between gas pressure and spark length . . . . . 156
- Tizzoni, on the radium treatment of rabies . . . . . 507
- Toning process . . . . . 233
- Tousey, new film-carrier of, for dental skiagraphy . . . . . 371, 372  
 on fluorescence, in conjunction with the X-rays, in stomachic examinations . . . . . 342  
 on X-rays in tuberculosis . . . . . 480
- Tracy, on high-frequency currents in epilepsy . . . . . 153  
 on radio-active treatment with thorium . . . . . 508
- Transformers . . . . . 184
- Transparencies and lantern slides or diapositives . . . . . 234
- Treatment of X-ray dermatitis . . . . . 408-412
- Triangulation method for the localization of foreign bodies . . . . . 303
- Tube, X-ray. (See Vacuum tube.)
- Tube-holder . . . . . 201  
 author's . . . . . 201
- Types of cells . . . . . 63  
 of vacuum tubes . . . . . 189
- U**
- Units of electrical measurement . . . . . 36
- Unna, on microscopy of dermatitic X-ray areas . . . . . 405  
 on pigmentation of the skin, due to the X-rays . . . . . 396
- Urinary bladder, X-ray examination for calculi in . . . . . 359
- Uskoff, on the action of light on ciliary movement . . . . . 512
- V**
- Vacuum tube, Bauer's . . . . . 194  
 blackening of . . . . . 197



- Vacuum tube, Caldwell's cavity . . . . 424  
 care of . . . . . 196, 197  
 consumption of . . . . . 198  
 Cossar's cavity . . . . . 424  
 Crookes's . . . . . 187, 429  
   position of . . . . . 216, 221  
   selection of, as to the  
     requirements of the  
     case . . . . . 218  
 degree of vacuum of . . . . 195, 196  
 distance of, from the plate . . 219  
   in therapeutics . . . . . 424  
 Ducretet's self-regulating . . . 192  
 electro-static regeneration of 195  
 essential features of . . . . . 188  
 explosion of . . . . . 198  
 fluorescence of, and appear-  
 ance of the electrodes, for  
   X-ray dosage . . . . . 440  
 hard, soft, and medium . . . 195  
 Hirschmann's monopol . . . . 194  
 life of . . . . . 198  
 mechanical regeneration of . 194  
 Müller's regulation . . . . . 192  
 osmosis regulation . . . . . 194  
 polarity and connections  
   of . . . . . 207, 208  
 position of, for therapeutics . . 424  
 puncture of anti-cathode of . 198  
 repumping of . . . . . 198  
 Sayen's self-regulating . . . . 190  
 self-regulating and regener-  
   ative . . . . . 189  
 stationary . . . . . 189  
 types of . . . . . 189  
 ventril . . . . . 197  
 water-cooling . . . . . 195
- Van Allen, on the value of the X-rays  
 in lupus vulgaris . . . . . 446
- Variable primary induction coils . . 178, 179
- Varnier, on the skiagraph in pelvim-  
 etry . . . . . 362, 363
- Vieruzhsky, on the diagnosis of tuber-  
 culosis by the X-rays . . . . . 319
- Viewing-box for X-ray negatives . . 236
- Villard, remarks of, on ventril tubes . 197
- Violet and ultra-violet rays in tuber-  
 culosis . . . . . 479, 480  
 (See Light.)
- Voelcker and Lichtenberg, on py-  
 elography . . . . . 358
- Volt . . . . . 37
- Voltaic alternatives . . . . . 67-68
- Vose and Howe, on the microscopy of  
 cancer after irradiation . . . . . 419
- Voss or Toepler influence machine . . . 50
- Vril interrupter . . . . . 173
- W**
- Wall cabinet . . . . . 64
- Walsham's sign in aneurisms . . . . . 334
- Walters, on X-ray filters . . . . . 426
- Washing the negative . . . . . 228
- Water-cooling vacuum tubes . . . . . 195
- Watt . . . . . 38
- Wave current . . . . . 58
- Wehnelt's interrupter . . . . . 175, 176
- Wells, on the multiple connection of  
 Crookes tubes in series . . . . . 425
- Wet cells . . . . . 63
- Wheatstone's reflecting method in  
 stereo-skiagraphy . . . . . 249
- White's circular, on the value and  
 medico-legal relationship of the  
 X-rays . . . . . 380-382
- Wiedemann, on radiant matter . . . . 157
- Wilkinson, his studies of the X-rays  
 in leprosy . . . . . 459
- Williams, C., on the X-rays in the  
 treatment of tuberculosis . . . . . 478
- Williams, F., fluorometer of . . . . . 438  
   on the screen examination of  
   the normal heart and dia-  
   phragm . . . . . 308  
   on the skiagraph in pelvim-  
   etry . . . . . 365  
   on the study of fifty cases  
   treated with radium bro-  
   mide . . . . . 503, 504
- Wimshurst influence machine . . . . . 47
- Wolfenden and Ross, on the action of  
 the X-rays on the bacillus prodigi-  
 osus . . . . . 390
- X**
- X-ray apparatus, hospital outfit . . . 204  
 portable outfit . . . . . 204  
 selection, care, and installa-  
 tion of . . . . . 203-207
- dermatitis . . . . . 395  
 acute form of . . . . . 400  
 causes of . . . . . 398, 399  
 chronic form of . . . . . 400  
 classification of . . . . . 399

- X-ray dermatitis, duration of the chronic form of.... 406, 407  
 frequency and susceptibility to, and latent stage of 401-404  
 pathological physiology of..... 404-406  
 physician's responsibility in cases of..... 382-387  
 preventive measures against 407, 408
- diagnosis of biliary calculi... 346, 347  
 of prostatic calculi.... 360, 361  
 of ureteral calculi.... 355-359  
 of vesical calculi... 350-355, 360  
 (See X-rays as a diagnostic agent.)
- dosage, the measurement of, by  
 chromoradiometer of Bordier. 433, 434  
 of Holz knecht.... 432  
 by Contremoulins' method. .... 439  
 by cryptoradiometer of Wehnelt..... 431  
 by current to the primary coil..... 427  
 by fluorescence of the tube and appearance of the electrodes.... 440  
 by fluorometer..... 438  
 by Guilleminot-Courtade method..... 438  
 by ionization of confined gases..... 436  
 by milliamperage of the secondary induced current..... 427, 428  
 by precipitation test... 436  
 by quantimeter of Kienböck..... 434  
 by radio-active standard of Phillips..... 437  
 by radiochromometer of Benoist..... 429-431  
 by radiometer of Courtade..... 438  
 of Freund..... 435  
 of Sabouraud and Noiré..... 432, 433  
 by selenium photometer..... 439, 440
- X-ray dosage, the measurement of, by  
 skiameter and penetrometer..... 431  
 by spintermeter..... 429  
 by the thermometric method..... 441
- exposure, factors varying time of 220
- negative, author's examining box for..... 236  
 how to view..... 234, 235  
 proper light for..... 235  
 when it is to be regarded as satisfactory..... 234  
 (See Photographic negative.)
- negatives, interpretation of, in diseases of the alimentary tract..... 240  
 in diseases of the soft structures..... 238  
 in diseases of the thorax..... 238-240  
 in diseases and tumors of bone..... 238  
 in genito-urinary affections..... 240-242  
 in locating foreign bodies 236
- X-rays, action of, on bacteria... 389-395  
 analgesic action of..... 493  
 charging action of..... 168  
 chemical and photographic effects of..... 166  
 diagnosis by. (See X-ray diagnosis; X-rays as a diagnostic agent.)  
 discovery of..... 157  
 fluorescence and phosphorescence of..... 161, 162  
 in forensic medicine..... 375-388  
 in military surgery..... 285, 286  
 physiological effects of..... 167  
 production of..... 160  
 quality of..... 220  
 radiability and penetrability of.. 160  
 reflection, refraction, polarization and interference of.. 162, 163, 164  
 table of permeability of..... 287  
 theories accounting for the probable nature of..... 167  
 uses of, in anatomy..... 252-255  
 in physiology..... 255, 256  
 value of, in a differential study of bones and joints..... 258

- X-rays, value of, in fractures..... 259  
 varieties of foreign bodies, as regards..... 286  
 velocity of..... 168  
 velocity of propagation of... 167, 168  
 visibility of..... 167
- X-rays as a diagnostic agent in\*callus formation..... 259, 260
- as a diagnostic agent in dentistry..... 372-374  
 in abscess of the antrum 373  
 in alveolar abscess... 374  
 in ankylosis of the inferior maxillary articulation..... 373  
 in detecting pieces of broken instruments.. 373  
 in fracture of the inferior maxillary bone.. 373  
 in necrosis of the maxilla..... 372  
 in orthodontia..... 374  
 in root-canal fillings.... 373  
 in unerupted teeth.... 372
- as a diagnostic agent in diseases of the alimentary system..... 336-349  
 of the intestine 344-346  
 of the liver... 346, 347  
 of the œsophagus..... 336, 337  
 of the pancreas... 348  
 of the spleen..... 348
- as a diagnostic agent in diseases of the bronchi and lungs.. 313-321  
 in abscess and gangrene..... 321  
 in acute miliary tuberculosis..... 319  
 in asthma..... 314  
 in atelectasis..... 320  
 in bronchiectasis.. 313  
 in bronchitis..... 313  
 in broncho - pneumonia..... 315  
 in cavitation..... 318  
 in emphysema... 315  
 in pneumonia.... 320  
 in pulmonary tuberculosis... 315-318
- X-rays as a diagnostic agent in diseases of the bronchi and lungs:  
 in thoracic tumors and enlarged glands..... 323, 324
- as a diagnostic agent in diseases of the circulatory system..... 324-335  
 in aortic aneurism. 333  
 in atheroma..... 335  
 in cardiac atrophy, hypertrophy, and dilatation..... 331  
 in dilatation of the aorta..... 335  
 in displaced aorta. 330  
 in displaced heart. 330  
 in enlarged glands. 335  
 in neoplasms.... 335  
 in pericarditis.... 332  
 in pulsating empyema..... 335
- as a diagnostic agent in diseases of the joints..... 282-285
- as a diagnostic agent in diseases of the pleura 321-324  
 in empyema..... 322  
 in hydro-pneumothorax and pyopneumothorax.. 323  
 in pleurisy with effusion..... 321  
 in pneumothorax.. 323  
 in subphrenic abscess..... 323
- as a diagnostic agent in fractures and dislocations..... 258-270  
 of the lower extremity..... 266-270  
 of the os innominatum, sacrum, and coccyx.. 270  
 of the ribs and sternum. 272  
 of the spinal column... 271  
 of upper extremity. 260-266
- as a diagnostic agent in genito-urinary diseases 349-361  
 in closure of the bladder 360  
 in prostatic calculi. 360, 361  
 in ureteral calculi.. 355-359  
 in vesical calculi..... 360
- as a diagnostic agent in gynæcology and obstetrics..... 362-367



- X-rays as a diagnostic agent in intestinal affections.. 344-346  
 in abdominal new  
 growths..... 346  
 in obstruction..... 345  
 in rectal imperforation. 345  
 in sounding and radiography..... 344  
 as a diagnostic agent in osseous diseases, tumors, and deformities..... 272-277  
 (See X-rays as a diagnostic agent in fractures and dislocations.)  
 as a diagnostic agent in pathological dislocations..... 270  
 as a diagnostic agent in rhinology, laryngology, and otology.... 367-369  
 in abscess of the antrum and frontal sinuses.. 368  
 in abscess of the mastoid process..... 369  
 in foreign bodies in the ear..... 369  
 in foreign bodies in the larynx..... 369  
 in ossification of the laryngeal cartilages... 369  
 as a diagnostic agent in stomachic affections 342-344  
 in gastroptosis..... 343  
 in stenosis of the pylorus..... 344  
 as a diagnostic agent in tumors of soft tissues..... 277-282  
 X-rays in the treatment of constitutional diseases 477-487  
 in leukæmia.. 482-487  
 in tuberculosis 477-482  
 in the treatment of cutaneous affections.. 444-460  
 of acne..... 452  
 of acne rosacea 453, 454  
 of acne vulgaris... 453  
 of alopecia areata. 447  
 X-rays in the treatment of cutaneous affections: of eczema..... 451  
 of favus and tinea tonsurans..... 449  
 of hyperidrosis... 458  
 of hypertrichosis..... 447-449  
 of kraurosis vulvæ. 458  
 of leprosy..... 459  
 of lupus erythematosus..... 444  
 of lupus vulgaris.. 444  
 of nævus..... 446  
 of pruritus ani and vulvæ..... 455  
 of psoriasis. . . 456, 457  
 of senile leg ulcers. 457  
 of sycosis..... 454, 455  
 of varicose veins... 457  
 of xeroderma pigmentosum.. 456, 457  
 in the treatment of malignant growths..... 460-477  
 in carcinoma of the breast..... 465-469  
 of the larynx..... 470  
 of the œsophagus.. 469  
 of the sternum... 469  
 of the stomach and intestines..... 470  
 of the uterus.. 470, 471  
 in sarcoma..... 473-477  
 in the treatment of various affections... 487-495  
 of epilepsy..... 495  
 of exophthalmic goitre..... 490-492  
 of hypertrophied prostate..... 492  
 of keloid..... 489  
 of trachoma.. 487-489
- Z**
- Zeisler, on the radiotherapy of acne 453  
 Zeit, on action of the X-rays on bacteria..... 391







University of California  
SOUTHERN REGIONAL LIBRARY FACILITY  
305 De Neve Drive - Parking Lot 17 • Box 951388  
LOS ANGELES, CALIFORNIA 90095-1388

Return this material to the library from which it was borrowed.

PRINTED IN U.S.A.

CAT. NO. 24 161



UC SOUTHERN REGIONAL LIBRARY FACILITY



A 000 450 761 2

WN100  
K19r  
1907

Kassabian, Mihran Krikor.  
Röntgen rays and electro-therapeuticd.

**MEDICAL SCIENCES LIBRARY**  
**UNIVERSITY OF CALIFORNIA, IRVINE**  
**IRVINE, CALIFORNIA 92664**

University of  
Southern  
Library